



Precision in Productivity™

SERVICE MANUAL

CAMCO

OUTPUT OVERLOAD CLUTCHES

WARNING

This is a controlled document. It is your responsibility to deliver this information to the end user of the DESTACO CAMCO or FERGUSON product. Failure to deliver this could result in your liability for injury to the user or damage to the machine. For copies of this manual, call your Customer Service Representative at 800-645-5207

INSTALLATION, OPERATION AND MAINTENANCE INSTRUCTIONS

SAFETY INSTRUCTIONS

1. Read your Overload Clutch Installation-Operation Instructions thoroughly before operating the unit for your safety and the protections of your unit.
2. CAMCO Overload Clutches are designed to protect the Index Drive *only* and will not protect against bodily injury.
3. Double check to be sure the power to the index drive is off and cannot be turned on while working on the equipment.
4. Use extreme caution with jammed or unbalanced loads which, when cleared, may set the machine in motion.
5. Keep all objects such as hands, clothing and tools away from rotating or moving parts.
6. Use safety glasses or equivalent to protect your eyes.
7. Dowel pins and mounting screws must not protrude from the drive plate or driven member, as the clutch could become a solid coupling.
8. High humidity, contaminants, or wash down applications may cause rust within the clutch, resulting in operational failure. Lubricate every six months or more frequently as the application requires.
9. The CAMCO Clutch is not a "FAIL SAFE" device and cannot be used on "overhauling" or "holding" load applications.

The above list includes major safety points to be observed, but should not be considered as limiting in safety precautions to be followed.

OPERATING PRINCIPLE

CAMCO Overload Clutches are designed for mounting on the output member of the CAMCO Index Drive. An Index Drive is essentially a variable ratio speed reducer. Each index provides an incremental output to input torque ratio, which may range from 1:1 in the center of the motion, to as high as 1000:1 in the beginning or end of the motion. As output torque equals input torque times the ratio, a clutch mounted on the input side provides no protection at the beginning or end of the motion.

CAMCO Overload Clutches provide zero backlash, high rigidity, low inertia and are specifically designed to be used in conjunction with CAMCO Index Drives.

Power is transmitted from the Index Drive through the body of the CAMCO Overload Clutch. The body contains spring loaded tapered seats in the drive plate (see Fig. 1). Torque settings are determined by the pressure the calibrated springs "seat" the plungers.

When an overload occurs which exceeds the torque setting of the clutch, the breakaway friction between the tapered plunger and the tapered seat forces the plungers outward from their seats. The movement of the plungers elevates the detector plate, actuating the limit switch (Fig. 2).

The CAMCO Overload Clutch always resets in its original position making it an excellent choice on applications that must remain registered or timed.

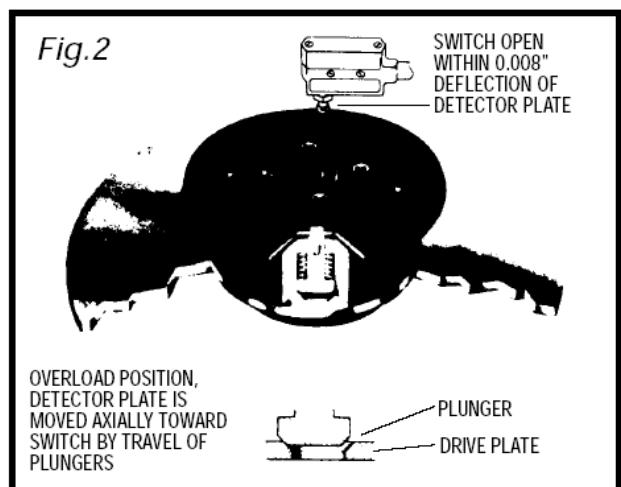
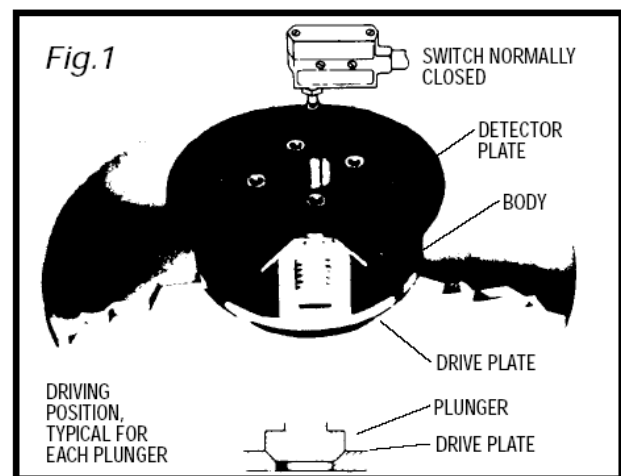

CLUTCH TYPES

CAMCO clutches are designed to meet specific application requirements. They are available in five basic designs.

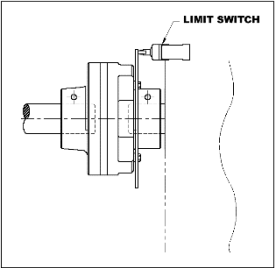
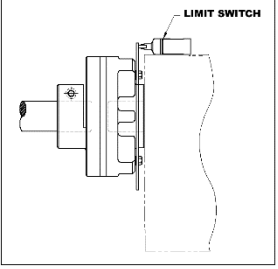
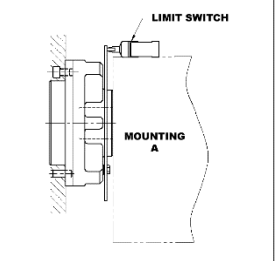
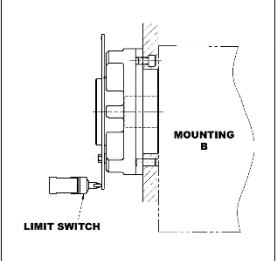
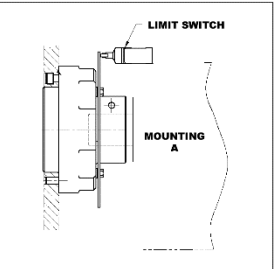
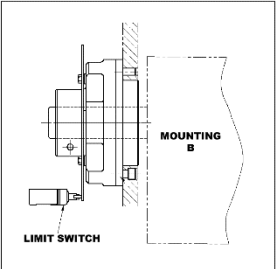
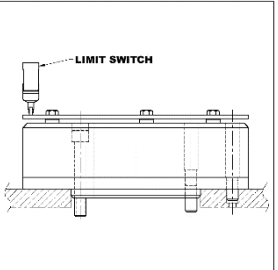
<p>.39C 2.3C 6.0C 11C 25C 41C</p>	<p>TYPE C</p> <ul style="list-style-type: none"> • Clamped (Shaft Mounted) Body & Hub <p>These clutches mount between Index Drives with shaft-only outputs and driven shafts. They provide a positive, rigid connection between two shafts.</p>		
<p>.39FC 2.3FC 6.0FC 11FC 25FC 41FC</p>	<p>TYPE FC</p> <ul style="list-style-type: none"> • Flange Mounted Body • Clamped Hub <p>These clutches flange-mount to the output flanged shaft of the Index Drive and provide a keyed-clamped hub connection to the driven shaft.</p>		
<p>.39F 2.3F 6.0F 11F 25F 41F</p>	<p>TYPE F</p> <ul style="list-style-type: none"> • Flange Mounted Body and Hub <p>These clutches mount to the output shaft of the Index Drive and provide a mounting surface for a dial plate, sprocket, gear, etc., resulting in a rigid, compact and accurate connection to the driven member.</p>		
<p>.39S 2.3S 6.0S 11S 25S 41S</p>	<p>TYPE S</p> <ul style="list-style-type: none"> • Shaft Mounted Body • Flange Mounted Hub <p>These clutches mount on Index Drives without flanges (with shaft outputs). The combination of keyed and clamped hub construction provides rigid and backlash-free shaft connections</p>		
<p>2.8D 4.0D 7.8D 18D 31D 32D 33DA 61D</p>	<p>TYPE D</p> <ul style="list-style-type: none"> • Flange Mounted <p>These clutches mount on Index Drives featuring large output mounting surfaces. The dial plate rests directly on the Index Drive output flange providing stability and accuracy.</p>		

REQUIRED ASSEMBLIES (FIG. 3)	CLUTCH TYPE			
	C	FC	F	S
HUB	①	①		
FLANGE PLATE	②	②	②	②
DRIVE PLATE	③	③	③	③
BODY (S, C)	④			④
DETECTOR PLATE	⑤			⑤
BODY (F, FC)		⑥	⑥	
PLUNGERS	⑦	⑦	⑦	⑦
SPRINGS	⑧	⑧	⑧	⑧

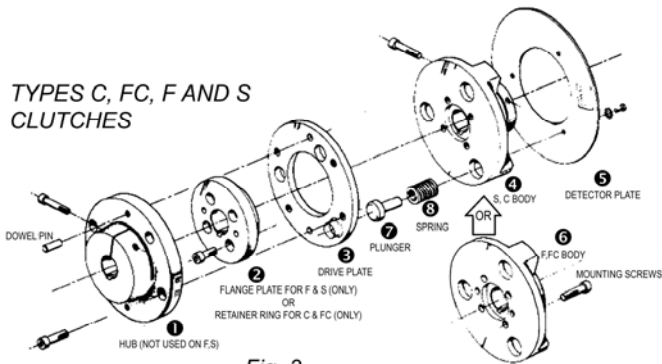

Fig. 3

INSTALLATION INSTRUCTIONS TYPES C AND FC OVERLOAD CLUTCHES

ASSEMBLY INSTRUCTIONS

See Fig. 3 for required parts

Important: To obtain maximum accuracy in positioning the DRIVEN MEMBER, the INDEX DRIVE "CAM SHAFT" must be in the EXACT CENTER OF DWELL position. See CAMCO drawing applicable to the Index Drive Model.

1. Insert PLUNGERS (7) into SPRINGS (8) and install the assemblies in the BODY pockets. Test for free movement of the plungers. Lightly lubricate the body pockets, springs and plungers with Mobil AW-2 or equivalent.

Caution: Do not over lubricate. Heavy lubrication may prevent clutch disengagement.

2. Install FLANGE PLATE (2) into the DRIVE PLATE (3). Lightly lubricate both sides of the DRIVE PLATE and the machined face of the BODY with Mobil AW-2 or equivalent.
3. Align the PLUNGERS with the tapered seats in the DRIVE PLATE.
4. Type C Clutches: Insert mounting screws through the FLANGE PLATE into the tapped holes in the BODY (4). Alternately tighten the screws until the flange plate is seated on the BODY.

Type FC Clutches: Insert the mounting screws through the BODY (6) and FLANGE PLATE into the tapped holes in the INDEX DRIVE flange. Alternately tighten the screws until the FLANGE PLATE is seated on the BODY.

5. Assemble the DETECTOR PLATE (5) on the clutch BODY and secure both the DETECTOR PLATE and the PLUNGERS with the detector plate mounting screws.
6. Install the assembled clutch on the output shaft or flange of the INDEX DRIVE.

7. Press the dowel pins in the HUB (1) until they protrude approximately .125" beyond the machined face of the HUB.
8. Insert the HUB mounting screws through the HUB into the tapped holes in the DRIVE PLATE. Tighten the HUB mounting screws.
9. Drive the dowel pins flush with the HUB shoulder.

WARNING: Hub mounting screws and dowel pins must not protrude from the drive plate as they may lock against the adjacent surface, making the clutch inoperative.

10. Place driven shaft in HUB (1). The respective shafts should not protrude from the face of the HUB or the FLANGE PLATE. Tighten clamp screws.
11. **Note:** Shafts must be aligned within .003" TIR and there must be an air gap between the DRIVE PLATE and CLUTCH BODY of .004" to .010". Check clearances with a shim or feeler gauge throughout the full diameter of the clutch.

Warning: Excessive misalignment will cause the coupling to lock.

12. Test for proper torque setting.

DISASSEMBLY INSTRUCTIONS

(Types FC and C)

1. Remove HUB mounting screws and separate the HUB from the CLUTCH. (Resistance may be caused by the dowel pins.)
2. Type C Clutch: Remove output shaft clamp screws
Type FC Clutch: Remove mounting screws.
3. Remove the clutch from the index drive.
4. Type C Clutch: Remove mounting screws
5. Place BODY with the PLUNGERS face down on a solid surface.

6. Remove DETECTOR PLATE mounting screws which will release the PLUNGER assemblies.

WARNING: The plunger assemblies are spring loaded and under tension. Bodily injury could

result if the plunger assemblies are not retained against a solid surface.

INSTALLATION INSTRUCTIONS TYPES F AND S CLUTCHES

ASSEMBLY INSTRUCTIONS

(See Fig. 3 for required parts)

Important: To obtain maximum accuracy in positioning the DRIVEN MEMBER, the INDEX DRIVE "CAM SHAFT" must be in the EXACT CENTER OF DWELL position. See CAMCO drawing applicable to the Index Drive Model.

1. Insert PLUNGERS (7) into SPRINGS (8) and install the assemblies in the BODY pockets. Test for free movement of the plungers. Lightly lubricate the body pockets, springs and plungers with Mobil AW-2 or equivalent.

Caution: Do not over lubricate. Heavy lubrication may prevent clutch disengagement.

2. Install FLANGE PLATE (2) into the DRIVE PLATE (3). Lightly lubricate both sides of the DRIVE PLATE and the machined face of the BODY with Mobil AW-2 or equivalent.
3. Align the PLUNGERS with the tapered seats in the DRIVE PLATE.

4. Type S Clutches: Insert mounting screws through the FLANGE PLATE into the tapped holes in the BODY (4). Alternately tighten the screws until the flange plate is seated on the BODY.

Type F Clutches: Insert the mounting screws through the BODY (6) and FLANGE PLATE into the tapped holes in the INDEX DRIVE flange. Alternately tighten the screws until the FLANGE PLATE is seated on the BODY.

5. Assemble the DETECTOR PLATE (5) on the clutch BODY and secure both the DETECTOR PLATE and the PLUNGERS with the detector plate mounting screws.

Note: Type F Clutch only. If alternate assembly with the clutch BODY mounted on the Index Drive flange is required, reassemble as follows:

Remove the mounting screws. Insert the mounting screws through the FLANGE PLATE first, and then the BODY, into the tapped holes in the INDEX DRIVE flange.

WARNING: Do not remove the detector plate mounting screws as they must retain the plunger assembly.

6. Install the assembled clutch on the output shaft or flange of the INDEX DRIVE.
7. Prepare the DIAL, SPROCKET or DRIVEN MEMBER with a center hole and mounting holes

to mate with the tapped holes in the DRIVE PLATE. (Refer to CAMCO assembly drawings.)

8. Install DIAL or DRIVEN MEMBER and check if it is free to rotate.
9. Tighten DIAL mounting screws. Disengage clutch and test for clearance between the DRIVE PLATE and BODY (approximately .002"). The center hole of the DIAL must also clear the FLANGE PLATE.

WARNING: Dial mounting screws must not protrude from the drive plate as they may lock against the adjacent surface, making the clutch inoperative.

10. Remove the flange plate and dial-drive plate assembly.

Caution: Do not loosen the dial screws.

11. Using the DRIVE PLATE as a "jig," drill and ream the DIAL dowel holes. Deburr all holes.
12. Install dowel pins through the DIAL into the DRIVE PLATE.

WARNING: Dowel pins must not protrude from the drive plate as they may lock against the adjacent surface, making the clutch inoperative.

13. Reassemble the FLANGE PLATE and DIAL DRIVE PLATE assembly to the clutch BODY.
14. Test for proper torque setting.

Note: for added reliability and/or high speed operation, a bronze bushing may be inserted between the DIAL PLATE and the FLANGE PLATE. Special bronze flange plates are also available from CAMCO.

DISASSEMBLY INSTRUCTIONS

(Types F and S)

1. Remove DIAL mounting screws.
2. Remove DIAL or other driven members by tapping under the DIAL to overcome dowel pin friction.
3. Type S Clutch: Remove output shaft clamp screws
Type F Clutch: Remove mounting screws
4. Remove the clutch from the index drive.
5. Type S Clutch: Remove mounting screws.
6. Place BODY with the PLUNGERS face down on a solid surface.
7. Remove DETECTOR PLATE mounting screws which will release the PLUNGER assemblies.

WARNING: The plunger assemblies are spring loaded and under tension. Bodily injury could result if the plunger assemblies are not retained against a solid surface

operational failure. Lubricate every six months or more frequently as the applications require.

CAMCO CLUTCHES are precision assemblies and should not be modified. Modification of the clutch will VOID THE WARRANTY.

WARNING

High humidity, contaminants or wash down applications may cause rust within the clutch resulting in

INSTALLATION INSTRUCTIONS TYPE D OVERLOAD CLUTCH FOR DIAL PLATE APPLICATIONS

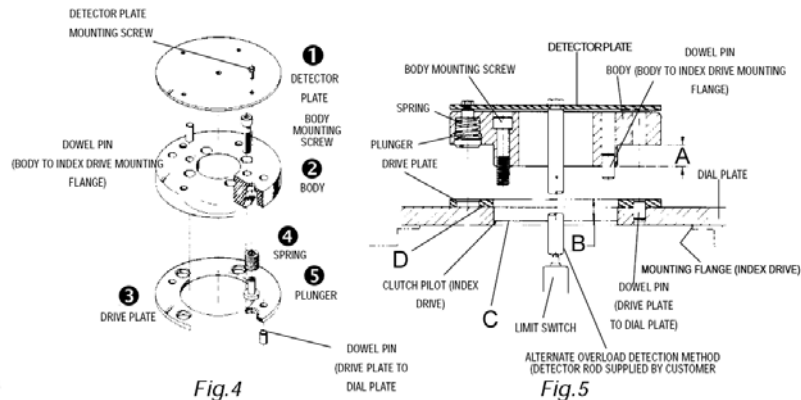

ASSEMBLY INSTRUCTIONS

(See Fig. 4 and Fig.5)

Important: To obtain maximum accuracy in positioning the DRIVEN MEMBER, the INDEX DRIVE "CAM SHAFT" must be in the EXACT CENTER OF DWELL position. See CAMCO drawing applicable to the Index Drive Model.

1. Lubricate output shaft and dial mounting surface of the Index Drive with Mobil AW-2 or equivalent.
2. Prepare the DIAL with center hole as required (Refer to CAMCO assembly drawings.)
3. Place the DIAL on the output mounting flange of the INDEX DRIVE and check if it is free to rotate.

Note: Dowel pins are factory installed when the clutch is supplied with the INDEX DRIVE.

4. Install dowel pins in the INDEX DRIVE mounting flange to insure proper positioning to the clutch BODY.
5. Insert BODY (2) into DRIVE PLATE (3) and through the center hole of the DIAL.

Note: Do not assemble SPRINGS, PLUNGERS or DETECTOR PLATE on the BODY.

6. Attach the clutch BODY to the INDEX DRIVE output mounting flange with the body mounting screws.

Note: A .005" minimum to .010" maximum clearance gap must exist between the DRIVE PLATE and the BODY, around the full circumference of the clutch.

7. Clearance Procedure (See Fig. 5)

A. Measure dimension "A" (bottom surface to BODY to bottom surface of BODY detent).

- B. Measure dimension "B" (top surface of DRIVE PLATE to top surface of clutch pilot).
- C. Subtract "B" from "A".
- D. If *less than* .005", add shim at surface "C" (between clutch pilot and bottom surface of BODY) to obtain clearance gap of .005" to .010".
- E. If *greater than* .010" grind BODY, (between DRIVE PLATE and DIAL PLATE) to obtain clearance gap of .005" to .010".

8. Remove BODY. Insert PLUNGERS (5) into SPRINGS (4) and install the assemblies in the BODY pockets. Test for free movement of the plungers. *Lightly* lubricate the body pockets, springs and plungers with Mobilgrease 77 or equivalent.

Caution: Do not over lubricate. Heavy lubrication may prevent clutch disengagement.

9. Align the PLUNGERS with tapered seats in the DRIVE PLATE (3) Re-install BODY.
10. Rotate the DIAL PLATE to desired position. Place .015" shim stock between the BODY and the DRIVE PLATE and alternately tighten body mounting screws, clamping the DIAL PLATE. Shim stock should be placed at 90° intervals. **Caution:** Do not cock the plunger. The plungers must retract evenly into the clutch body.
11. Using the BODY and DRIVE PLATE as a "JIG," drill and ream the DIAL PLATE dowel holes. The holes should not go completely through the DIAL PLATE. DIAL PLATE dowel pins should be .125" shorter than the combined thickness of the DIAL and DRIVE PLATES.

12. Disassemble, deburr and clean all parts. Remove .015" shim stock.
13. Dowel pin the DRIVE PLATE to the DIAL PLATE.
Note: Dowel pins are factory installed when the CLUTCH and DIAL PLATE are supplied with the INDEX DRIVE.
Warning: Dowels pins must not protrude from the DRIVE PLATE or DIAL PLATE as they may lock against the adjacent surface, making the clutch inoperative.
14. *LIGHTLY* lubricate the DRIVE PLATE and mating surface of the clutch BODY with Mobilgrease 77 or equivalent.
15. Assemble complete clutch. Alternately tighten body mounting screws following the procedures in instruction #10.
16. Assemble the DETECTOR PLATE on the clutch BODY and secure both the DETECTOR PLATE and the PLUNGERS with the detector mounting screws.
17. Check if DIAL PLATE can be disengaged.
18. Test for proper torque setting. The clutch should disengage within 20% of the nameplate torque rating.

DISASSEMBLY INSTRUCTIONS (TYPE D)

1. Remove DETECTOR MOUNTING screws which will release the PLUNGER assemblies.
2. Alternately loosen and remove the BODY mounting screws.
Warning: The plunger assemblies are spring loaded and under tension. Bodily injury could result if the plunger assemblies are not released *slowly* by the body mounting screws.
3. Remove the clutch BODY.
Note: It may be necessary to tap under the DIAL PLATE to overcome the friction caused by the dowel pins that register the body to the mounting flange.
4. Clean and inspect all parts for wear.
5. Lubricate per assembly instructions 1, 8, and 14.

WARNING

High Humidity, contaminants or wash down applications may cause rust within the clutch resulting in operational failure. Lubricate every six months or more frequently as the applications require.

CAMCO CLUTCHES are precision assemblies and should not be modified. Modification of the clutch will VOID THE CAMCO WARRANTY.

APPLICATION RECOMMENDATIONS

1. Clutch operation in dusty or corrosive environments may require special preparation. Contact CAMCO for special modifications.
2. On applications other than the output of a CAMCO Index Drive, clutch speeds must not exceed 100 RPM.
3. High humidity, contaminants, or wash down applications may require special protection. If rust forms within the clutch, it may act as a solid coupling and will not release under overload conditions. Lubricate every six months or more frequently as the application requires.
Caution: *Lubricate the spring pockets with a light film to grease. Heavy lubrication of the spring pocket may lock the plunger, due to hydraulic pressure, preventing clutch disengagement.*
4. Use bronze bushings on sprockets, dials, gears or pulleys when used at the high end of the speed range (100 RPM) to reduce wear. Special bronze flange plates are available.
5. Clutch couplings require accurate shaft alignment of .003" TIR. Insure that a clearance gap is maintained between the body and the drive plate around the full circumference to the clutch (Type FC, C).
6. Use flange mounted clutches and clutch couplings whenever possible. These models provide superior mounting reliability (Type D, F, FC).
7. Dowel pins should not protrude from the drive plate or driven members, as they may lock against the adjacent surface.
8. Do not operate without the detector limit switch, electrically disconnecting the prime mover (motor), as galling of the contacting surfaces may result.
9. On high inertia applications, braking the prime mover is recommended, in the dwell cycle of the INDEX DRIVE, to minimize over travel.
10. CAMCO recommends using limit switches with rated travel not exceeding .008" for actuation.
11. The torque required to re-engage the clutch is usually 25% of the rating. Contact CAMCO for special design, anti-friction materials if the clutch is to be used with very low torque settings.
12. Never use the clutch with a torque setting close to the calculated operating torque. Actual torques may be higher. Torque spring tolerances and coefficients of friction vary with temperature and application. Allow 130% (1.3 service factor) when applying a CAMCO clutch.



Precision in Productivity™

DESTACO
CAMCO & FERGUSON Products
1444 South Wolf Road
Wheeling, IL 60090
USA
ph: 847-459-5200
toll-free: 800-645-5200
fax: 847-459-3064
camco@destaco.com

ISO 9001:2008 Registered

DE-STA-CO Headquarters
Auburn Hills, Michigan USA
248-836-6700
marketing@destaco.com

destaco.com

DESTACO Europe
Germany
+49-6171-705-0
europe@destaco.com

DESTACO Asia
Thailand
+66-2-326-0812
info@destaco.com

DESTACO South America
Brazil
0800-124070
samerica@destaco.com

This publication is for information purposes only and should not be considered a binding description of the product except if confirmed in writing by DESTACO

© DE-STA-CO 2004-2016
All rights reserved
Printed in U.S.A.
SKU 0136-0516