



A **BOVER** COMPANY

**Automation**  
**Robohand FERGUSON**  
**CAMCO**

**SERVICE MANUAL**  
**MINIATURE RGD/RGS INDEX DRIVES**  
**MODELS**  
**40, 50, 70, 80 RGD/RGS**

**WARNING**

This is a controlled document. It is your responsibility to deliver this information to the end user of the CAMCO or FERGUSON product. Failure to deliver this could result in your liability for injury to the user or damage to the machine. For copies of this manual, call your Customer Service Representative at 800-645-5207

## TABLE OF CONTENTS

INTRODUCTION .....	2
WARNINGS AND CAUTIONS .....	2
OIL SEAL REMOVAL .....	2
SPARE PARTS KIT .....	2
DISASSEMBLY .....	3
REMOVAL OF OUTPUT SHAFT .....	3
INSPECTION OF CAM FOLLOWERS .....	3
FOLLOWER REMOVAL .....	3
REMOVAL OF BEARINGS .....	3
INPUT SHAFT/ CAM REMOVAL .....	4
ASSEMBLY .....	4
PRIOR TO REASSEMBLY .....	4
ASSEMBLING INPUT SHAFT .....	4
ASSEMBLING OUTPUT SHAFT .....	5
SETTING CAM.....	5
HOW TO ORDER PARTS .....	7
BALLOONED PARTS DRAWINGS .....	8
PARTS LIST .....	9

## INTRODUCTION

---

This service manual pertains to the disassembly and assembly of CAMCO's Miniature RGD Series Index Drives MODELS 40, 50, 70 & 80RGD/RGS.

The manual is to be used in conjunction with the General Service Manual which describes the lubrication and general maintenance of CAMCO Index Drives.

For your convenience in identifying and ordering spare or replacement parts, a complete Bill of Materials is included in this manual.

Some users of Index Drives have the facilities and trained personnel to accomplish service repair. You must determine the extent to which intricate servicing should be done in your facility. When in doubt, CAMCO recommends that CAMCO trained servicemen make the repairs.

## WARNINGS AND CAUTIONS

---

Statements in this manual preceded by the words *WARNING* or *CAUTION* and printed in italics are very important. We recommend you take special notice of these during service or repair.

### *WARNING*

Means there is the possibility of personal injury to yourself or others.

### *CAUTION*

Means there is the possibility of damage to the CAMCO unit.

## OIL SEAL REMOVAL

---

The only repair possible without disassembly of the indexer is replacement of oil seals. To remove oil seals, drill a number of holes into the case of the seal. The seal may then be removed with a pointed tool. Be sure to remove all metallic chips created during the drilling of removal holes. A new seal may be installed as outlined in the "Oil Seal Installation Recommendations" section of the "General Service Manual".

## SPARE PARTS KIT

---

CAMCO offers a Spare Parts Kit for all CAMCO index drive models CAMCO builds. These kits include oil seals, bearings, shims and cam followers. These are components that will most likely require replacement during repair of your index drive. CAMCO recommends a Spare Parts Kit be purchased and kept on hand prior to any disassembly of your CAMCO drive.

A complete list of components supplied in the Spare Parts Kit can be found in the parts list located in the rear of this manual. The asterisk behind the item number indicates those parts supplied with the Spare Parts Kit.

## BEFORE STARTING

---

Before starting disassembly of your CAMCO unit you should read and review the following instructions. These provide important information on parts and procedures necessary to successfully complete your repair.

Comply with all *Warnings* and *Cautions*.

Read the "Trouble Shooting Guide" section of your "General Service Manual" before disassembling CAMCO units. CAMCO recommends returning defective equipment for inspection and repair whenever possible.

CAMCO uses Loctite to secure all screws and setscrews. If you encounter a fastener that is difficult to remove, apply heat to the screw and remove while still warm.

## DISASSEMBLY

1. Remove all accessory equipment such as clutches, reducers, sprockets, etc.
2. Drain oil and flush with flushing solvent. Retain any chips or broken pieces that you may find. These may aid in diagnosis.
3. Remove round access cover. This may be done by drilling a hole in the cover, threading in a sheet metal screw, and pulling with pliers.

### 4. REMOVAL OF OUTPUT SHAFT.

- A. Rotate the input shaft until the output is in dwell.
- B. Remove all upper and lower output bearing cartridge capscrews.

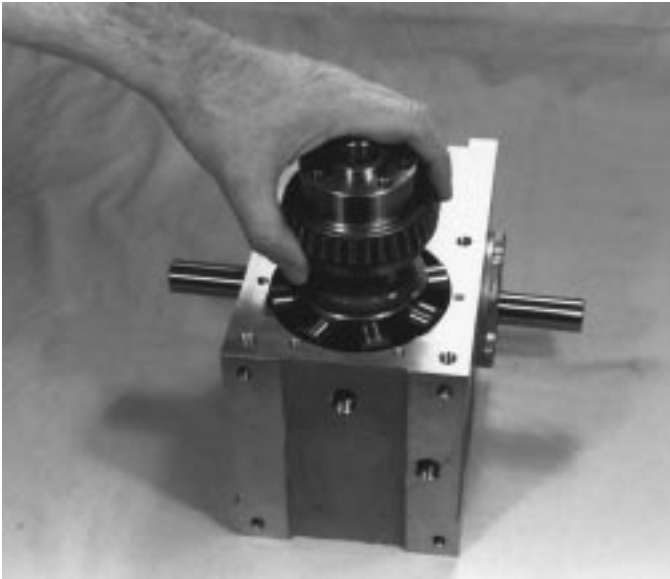

- C. Remove the upper and lower output cartridge capscrews.

NOTE: Keep the shims with the cartridge. You will be asked to reinstall or replace with same shim thickness during assembly.

- D. Pull the output bearing thru the cartridge opening. It may be necessary to tap on the lower end of the output shaft with a soft faced hammer to drive the output shaft and bearing cup out.

### 5. INSPECTION OF CAM FOLLOWERS.

Inspect followers for damage or radial

looseness. It should not exceed .001 inch. Do not confuse radial looseness with axial endplay. Endplay will be from .03 to .06 as a normal condition. If it exceeds .06 it may require follower replacement.



NOTE: Generally, followers are replaced as added insurance against eventual failure.

### 6. REPLACEMENT OF CAM FOLLOWERS.

Followers replacement in the field is not recommended by CAMCO. All follower removal and replacement must be done at CAMCO. Simply follow "RETURN FOR REPAIR" instructions in the "General Service Manual". CAMCO will provide quick turnaround on standard follower replacement or standard follower wheel/shaft assembly replacement.

This is due to the size of the followers and the tools required to properly remove and install without damage to the follower stud or follower wheel.

### 7. REMOVAL OF BEARINGS.

- A. Remove the output bearing cones from the output shaft using a small diameter aluminum bar and hammer. Place the bar against the protruding edge of the cone and tap with hammer, working around the perimeter to prevent binding. Continue this until the cone is free of shaft.

- B. Remove any remaining output bearing from the housing by the same method as described in step "A".



#### 8. INPUT SHAFT/CAM REMOVAL.

NOTE: The output shaft must be removed prior to input shaft removal.

- A. Rotate the input shaft and inspect all parts for wear or damage. Endplay in the input shaft is not permissible.
- B. Match mark both input cartridges relative to the housing. These must be reinstalled in the same side and position since they are eccentric.
- C. Remove all input bearing cartridge capscrews.
- D. Tap on end of input shaft to drive the opposite cartridge from the housing. Then drive the shaft in the opposite direction for removal of the remaining cartridge.

NOTE: Keep the shims with their respective cartridges. You will be asked to reinstall or replace the same shim thickness during reassembly.

- E. Use a wheel puller to remove one bearing cone from the input shaft.

- F. Support the side of the cam where the bearing was removed and press or drive the shaft through from the remaining bearing side. This will remove the remaining bearing and cam simultaneously.

- 9. Remove input bearing cups from the cartridges with a wheel puller, by prying or by drilling and tapping for jack screws.

- 10. Press out all oil seals from both input and output cartridges.

## ASSEMBLY

### PRIOR TO REASSEMBLY

Clean and deburr all parts before reassembly.

Follow tightening torque and Loc-tite™ recommendations as outlined in the General Service Manual.

- 1. Use an arbor press to press bearing cups into input cartridges. Coat outside of cup and the cartridge bore with anti-sieze lubricant prior to pressing. Fill cavity of cartridges with bearing grease recommended in the "General Service Manual".

#### 2. ASSEMBLING INPUT SHAFT.

- A. Use arbor to press cam onto shaft. Be sure key is installed into shaft. Apply anti-seize lubricant on shaft and cam bore prior to pressing.
- B. Center cam on shaft.
- C. Use an arbor to press bearing cones onto shaft. Coat shaft and bearing bore with anti-sieze lubricant prior to pressing.
- D. Install the input cartridges. Be sure to install the same exact shims or equivalent height as removed during disassembly.
- E. Line up match marks.
- F. Tighten cartridge mounting screws.
- G. If endplay exists remove an equal amount of shims from each side until there is a small amount of drag (1 to 2 inch ozs.) from preloading the bearings. In rare instances it may be necessary to remachine the cartridges if all shims have been removed and endplay still exists.

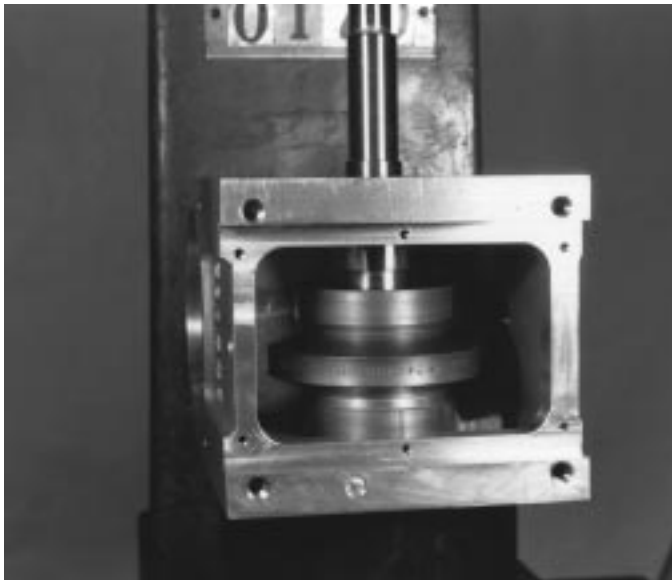

- H. Loosen the cartridge screws and rotate the cartridge tops to the most rearward position attainable within the slots provided in the cartridges.

### 3. ASSEMBLING OUTPUT SHAFT

- A. Install bearing cones on the output shaft.  
Coat the shaft and bore with an anti-sieze lubricant prior to installation. The bore of the bearing should be heated prior to pressing, if a heat gun is available. Tap in place.
- B. Install the bearing cup in the lower output bore of the housing. Coat bore and cup with anti-sieze lubricant and tap in place.
- C. Position the cam so the dwell rib is facing the output end of the housing. (Keyways facing rearward.)
- D. Insert the output shaft/follower wheel assembly into the housing. Be sure the followers straddle the dwell rib during insertion.
- E. Install the upper output bearing cup in the housing and the cup with anti-sieze lubricant and tap into place.
- F. Install both lower and upper output cartridges with the equivalent shim thickness removed in disassembly.
- G. Tighten mounting screws.

- H. If endplay exists, remove shims until there is a small amount of drag from preloading the bearings. In rare instances it may be necessary to remachine the cartridges if all shims are removed and endplay still exists.

### 4. SETTING THE CAM

CAUTION: This mechanism is designed to operate with adjacent followers in close contact along their entire width with the surface of the cam during the dwell period. Unless this condition is achieved by proper installation, the mechanism will not transmit its rated load, and furthermore, serious damage to the cam and output shaft will occur.

- A. Place the cam in dwell (Keyway facing rearward).
- B. Rotate the tops of both input cartridges toward the output until the cam followers touch the cam.
- C. Shift the cam axially (using shims between the housing and cartridge) until two adjacent followers are in full contact with the cam rib. (This will also require adjustment to the eccentric cartridges along with the axial adjustment of the cam).
  - 1.) If there is a gap at the root of the follower the cam should be shifted toward the follower.

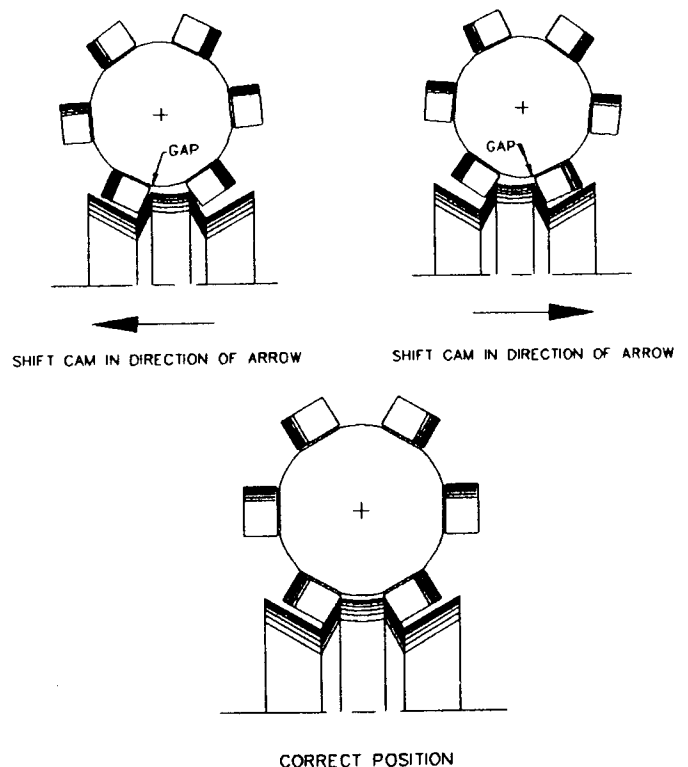

- 2.) If there is a gap at the tip of the follower the cam should be shifted away from the follower.
- D. Apply "Prussian Blue" to entire cam track.
- E. Rotate the cam shaft slowly with a small handrank to ensure that:
- 1.) Both rollers are in contact with the cam rib in dwell. Look for uniform bluing pattern.
  - 2.) The follower is free at center of crossover track.
  - 3.) You do not encounter unusual resistance in motion. The bluing pattern should be fairly uniform from side to side during motion. If a patch of blueing is worn off the outside of the cam rib on one side of the cam and not the other, shift the cam .002 to .005 inches in the direction of the worn side. Do not overshift the cam or knocking will occur.
  - 4.) The cam bluing should never be worn off the leading or exit edges of the cam ribs. If so this is an indication that the cam is not adjusted properly.
  - 5.) There should be no looseness in any dwell. If there is, adjust the eccentric input cartridges to slightly preload the loosest dwell.
- F. Tighten the input cartridge capscrews and scribe new match marks on cartridge and housing.
- G. Double check for endplay in output shaft. Endplay is not permissible in output shaft.
- H. Remove the input cartridges (one at a time) and coat the surface between the shims and the housing with "General Electric Silicone Rubber RTV-6" (to insure against leakage) and reinstall, aligning the match marks, tighten the screws and dowel in place.
- I. Remove the output cartridges (one at a time) and coat the surface between the shims and the housing with "General Electric Silicone Rubber RTV-6" (to insure against leakage) and reinstall, aligning the match marks and tighten the screws.

5. Install a new access cover. Press in flush with housing.
6. Grease pack the main output bearing with lubricant specified in the "General Service Manual".
7. Install new oil seals as described in the "General Service Manual".
8. Fill with lubricant recommended in the "General Service Manual". (See oil capacities below)

#### Oil Capacities

40RGD/RDS = 6 oz.

50RGD/RGS = 16 oz.

70RGD/RGS = 20—24 oz.

80RGD/RGS = 30—38 oz.

CAUTION: Be sure to add the amount shown above. Too low a level may result in unit failure.

### 40, 50, 70 & 80 OIL LEVEL CAPACITIES

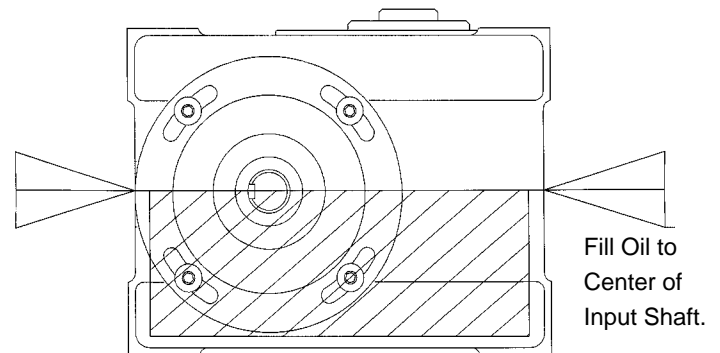

## HOW TO ORDER PARTS

Please refer to parts list shown in this manual. This parts list is for a standard Index Drive. If you feel your drive is nonstandard or you are in doubt you should contact CAMCO Customer Service at (847) 459-5200 and request a Bill of Material for your specific unit based on serial number. CAMCO maintains records on all units for a period of ten years.

You may order parts per the standard Bill of Material even if your unit is nonstandard. CAMCO's order entry people will review the closed order file based on the following information and supply you with the correct part.

### REQUIRED INFORMATION

1. Original purchase order number (if available)
2. Customer name (original purchaser of drive)
3. Model number (located on name plate)
4. Serial number (located on name plate)
5. Approximate date of purchase.

TO ORDER PARTS contact CAMCO "Order Entry Department" Wheeling, Illinois

Phone (847) 459-5200 or Fax (847) 459-3064

- A. Describe the parts required and the 14 digit part number as listed in the Standard Bill of Materials or a Special Bill of Materials pertaining to your unit. State if you are using a Standard or Special bill of material.
- B. Give as much of the above required information as possible.

### ON WARRANTY

Replacement parts CAMCO will send freight prepaid via most practical means.

CAMCO will issue a "Returned Material Authorization Number" (RMA#) for the return of defective parts for inspection. CAMCO will bill customer for repair parts. When inspection of returned parts has been completed and determined to be a warranty problem, CAMCO will issue a credit to the customer for the repair parts and freight charges.

### ON NON-WARRANTY

Replacement or spare parts, with approved credit, are F.O.B. our plant Wheeling, Illinois.



# 40, 50, 70 & 80RGD/RGS

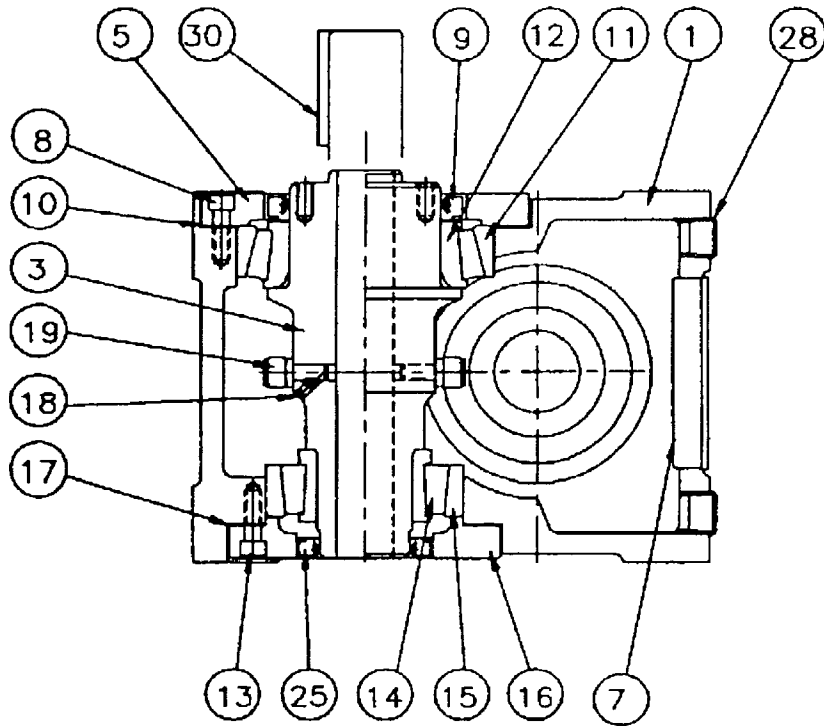

SIDE VIEW

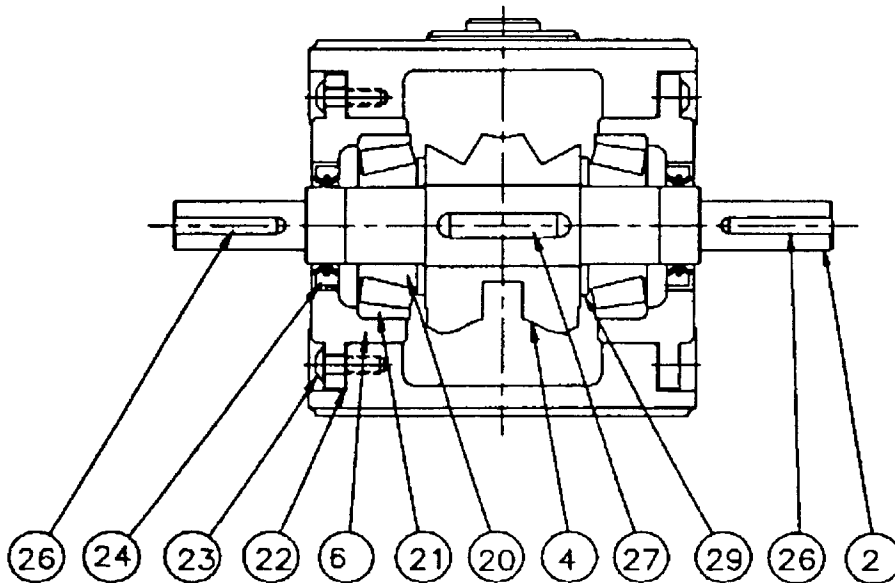

END VIEW

## PARTS LIST FOR 40RGD INDEX DRIVE (STANDARD CONFIGURATION)

1 .....	4MD55426001002	Housing
2 .....	4MB51870007002	Input Shaft Dbl
.....	4MA49071007001	Input Shaft Sgl
3 .....	4MB51609004006	Output Shaft/Foll Whl 6 Hole 3/8 Foll
.....	4MB51610004008	Output Shaft/Foll Whl 8 Hole 3/8 Foll
.....	4MB51611004010	Output Shaft/Foll Whl 10 Hole 1/4 Foll
.....	4MB51612004012	Output Shaft/Foll Whl 12 Hole 1/4 Foll
4 .....	_____	"Cam, (Specify Number Of Stops And "
.....	_____	"Index Time, Contact Camco For "
.....	_____	"Assistance, Order In Matched Sets)"
5 .....	4MB51655003002	"Cart, Output Large "
6 .....	4MB51874003001	"Cart, Input"
7 .....	4MA51903000000	Bore Plug
8 .....	95A51910300000	Shcs M4 X 10mm Lg.
9 .....	84D07329470000	Oil Seal C/R 13534
10 .....	4MA51916018800	Shim Outp Lg .002
.....	4MA51916028800	Shim Outp Lg .005
.....	4MA51916038800	Shim Outp Lg .010
.....	4MA51916048800	Shim Outp Lg .003
11 .....	86D07328270022	Bearing Cup L68111
12 .....	86D07328270021	Bearing Cone L68149
13 .....	95A51910300000	Shcs M4 X 10mm Lg.
14 .....	86D07328090021	Bearing Cone Lm 12749
15 .....	86D07328090022	Bearing Cup Lm12711
16 .....	4MA51652003002	"Cart, Output Small "
17 .....	4MA51915018800	Shim Outp Sm .002
.....	4MA51915028800	Shim Outp Sm .005
.....	4MA51915038800	Shim Outp Sm .010
.....	4MA51915048800	Shim Outp Sm .003
18 .....	95A33042030000	Sss M 3 X 5 Lg (Cone Pt)
19 .....	82A49589000000	Cam Follower 3/8 Dia.
.....	82A49590000000	Cam Follower 1/4 Dia.
20 .....	86D07328120021	Bearing Cone Lm11949
21 .....	86D07328120022	Bearing Cup Lm11910
22 .....	4MA51914018800	Shim 40rgd Inp .002
.....	4MA51914028800	Shim 40rgd Inp .005
.....	4MA51914038800	Shim 40rgd Inp .010
.....	4MA51914048800	Shim 40rgd Inp .003
23 .....	95A51911070000	Bhcs M4 X 10mm Lg.
24 .....	84D07329480000	Oil Seal C/R 7440
25 .....	84D07329540000	Oil Seal C/R 8017
26 .....	M04K088	Key 4mm Xq X .88 Lg
27 .....	M06K108	Key 6mm Sq X 1.08
28 .....	95A33002140000	Plug .12-27 Npt Flush
29 .....	_____	Not Used On 40 Rgd/Rgs
30 .....	_____	Not Used On 40 Rgd
31 .....	_____	Not Used On 40 Rgd/Rgs
32 .....	99A44547180000	Service Manual Miniatures
33 .....	99A44547010000	General Service Manual

PARTS LIST FOR 40RGS INDEX DRIVE (STANDARD CONFIGURATION)

1 .....	4MD55426001002	Housing
2 .....	4MB51870007002	Input Shaft Dbl
.....	4MA49071007001	Input Shaft Sgl
3 .....	4MB51614004006	Output Shaft/Foll Whl 6 Hole 3/8 Dia Sgl
.....	4MB51615004008	Output Shaft/Foll Whl 8 Hole 3/8 Dia Sgl
.....	4MB51616004010	Output Shaft/Foll Whl 10 Hole 1/4 Dia Sgl
.....	4MB51617004012	Output Shaft/Foll Whl 12 Hole 1/4 Dia Sgl
.....	4MB51899004006	Output Shaft/Foll Whl 6 Hole 3/8 Dia Dbl
.....	4MB51900004008	Output Shaft/Foll Whl 8 Hole 3/8 Dia Dbl
.....	4MB51901004010	Output Shaft/Foll Whl 10 Hole 1/4 Dia Dbl
.....	4MB51902004012	Output Shaft/Foll Whl 12 Hole 1/4 Dia Dbl
4 .....	_____	"Cam, (Specify Number Of Stops And "
.....	_____	"Index Time, Contact Camco For "
.....	_____	"Assistance, Order In Matched Sets)"
5 .....	4MB51655003002	"Cart, Output Large "
6 .....	4MB51874003001	"Cart, Input"
7 .....	4MA51903000000	Bore Plug
8 .....	95A51910300000	Shcs M4 X 10mm Lg.
9 .....	84D07329470000	Oil Seal C/R 13534
10 .....	4MA51916018800	Shim Outp Lg .002
.....	4MA51916028800	Shim Outp Lg .005
.....	4MA51916038800	Shim Outp Lg .010
.....	4MA51916048800	Shim Outp Lg .003
11 .....	86D07328270022	Bearing Cup L68111
12 .....	86D07328270021	Bearing Cone L68149
13 .....	95A51910300000	Shcs M4 X 10mm Lg.
14 .....	86D07328090021	Bearing Cone Lm 12749
15 .....	86D07328090022	Bearing Cup Lm12711
16 .....	4MA51652003002	"Cart, Output Small "
17 .....	4MA51915018800	Shim Outp Sm .002
.....	4MA51915028800	Shim Outp Sm .005
.....	4MA51915038800	Shim Outp Sm .010
.....	4MA51915048800	Shim Outp Sm .003
18 .....	95A33042030000	Sss M 3 X 5 Lg (Cone Pt)
19 .....	82A49589000000	Cam Follower 3/8 Dia.
.....	82A49590000000	Cam Follower 1/4 Dia.
20 .....	86D07328120021	Bearing Cone Lm11949
21 .....	86D07328120022	Bearing Cup Lm11910
22 .....	4MA51914018800	Shim 40rgd Inp .002
.....	4MA51914028800	Shim 40rgd Inp .005
.....	4MA51914038800	Shim 40rgd Inp .010
.....	4MA51914048800	Shim 40rgd Inp .003
23 .....	95A51911070000	Bhcs M4 X 10mm Lg.
24 .....	84D07329480000	Oil Seal C/R 7440
25 .....	84D07329540000	Oil Seal C/R 8017 (FOR DBL OUTPUT)
.....	4MA51904000000	BORE PLUG 1.250 (FOR SGL OUTPUT)
26 .....	M04K088	Key 4mm Xq X .88 Lg
27 .....	M06K108	Key 6mm Sq X 1.08
28 .....	95A33002140000	Plug .12-27 Npt Flush
29 .....	_____	Not Used On 40 Rgd/Rgs
30 .....	M05K125	Key Metric
31 .....	_____	Not Used On 40 Rgd/Rgs
32 .....	99A44547180000	Service Manual Miniatures
33 .....	99A44547010000	General Service Manual

## PARTS LIST FOR 50RGD INDEX DRIVE (STANDARD CONFIGURATION)

1 .....	5MD55427001002	Housing
2 .....	5MC52018007002	"Shaft, Input"
3 .....	5MC52026004006	Output Shaft/Foll Whl 6 Hole 7/16 Dia.
.....	5MC52027004006	Output Shaft/Foll Whl 6 Hole 9/16 Dia.
.....	5MC52025004008	Output Shaft/Foll Whl 8 Hole 7/16 Dia.
.....	5MC52023004010	Output Shaft/Foll Whl 10 Hole 1/4 Dia.
.....	5MC52024004010	Output Shaft/Foll Whl 10 Hole 7/16 Dia.
.....	5MC51673004012	Output Shaft/Foll Whl 12 Hole 1/4 Dia.
4 .....	_____	"Cam, (Specify Number Of Stops And "
.....	_____	"Index Time, Contact Camco For "
.....	_____	"Assistance, Order In Matched Sets)"
5 .....	5MB52029003002	"Cart, Output Lg"
6 .....	5MB52019003002	"Cart, Input Ecc "
7 .....	5MA52057000000	Bore Plug 2.756
8 .....	95A33040030000	Shcs M5 X 10
9 .....	84D07329560000	Oil Seal C/R 17754
10 .....	5MA52009018800	Shim Outp .002 Tk
.....	5MA52009028800	Shim Outp .005 Tk
.....	5MA52009038800	Shim Outp .010 Tk
.....	5MA52009048800	Shim Outp .003 Tk
11 .....	86D07328390022	Brg Cup Lm102910
12 .....	86D07328390021	Brg Cone Lm 102949
13 .....	95A33040030000	Shcs M5 X 10
14 .....	86D07328200021	Brg Cone L45449
15 .....	86D07328200022	Brg Cup L45410
* .....	5MB52020003002	"Cart, Output Sm "
17 .....	5MA52010018800	Shim Outp .002 Tk
.....	5MA52010028800	Shim Outp .005tk
.....	5MA52010038800	Shim Outp .010 Tk
.....	5MA52010048800	Shim Outp .003 Tk
18 .....	95A33042120000	Sss M4 X 8 Lg Cone Point
.....	95A33042050000	Sss M3 X 8 Lg Cone Point
19 .....	82A49590000000	Cam Follower 1/4 Dia
.....	82A49591000000	Cam Follower 7/16 Dia
.....	82A49592000000	Cam Follower 9/16 Dia
20 .....	86D07328120021	Bearing Cone Lm11949
21 .....	86D07328120022	Bearing Cup Lm11910
22 .....	5MA52011018800	Shim Inp .002 Tk
.....	5MA52011028800	Shim Inp .005 Tk
.....	5MA52011038800	Shim Inp .010 Tk
.....	5MA52011048800	Shim Inp .003 Tk
23 .....	95A51911110000	Bhcs M5 X 12
24 .....	84D07329480000	Oil Seal C/R 7440
25 .....	84D07329550000	Oil Seal C/R 11067
26 .....	M05K125	Key Metric
27 .....	M08K138	Key 8 X 7mm X 1.38 Lg
28 .....	95A33002140000	Plug .12-27 Npt Flush
29 .....	5MA52182000000	"Spacer, Cam "
30 .....	_____	Not Used On 50 Rgd
31 .....	_____	Not Used On 50 Rgd/rgs
32 .....	99A44547180000	Service Manual Miniatures
33 .....	99A44547010000	General Service Manual

## PARTS LIST FOR 50RGS INDEX DRIVE (STANDARD CONFIGURATION)

1 .....	5MD55427001002	Housing
2 .....	5MC52018007002	"Shaft, Input"
.....	5MC52041004006	Output Shaft/Foll Whl 6 Hole 9/16 Dia. Sgl
.....	5MC52040004006	Output Shaft/Foll Whl 6 Hole 7/16 Dia. Sgl
.....	5MC52039004008	Output Shaft/Foll Whl 8 Hole 7/16 Dia. Sgl
.....	5MC52038004010	Output Shaft/Foll Whl 10 Hole 7/16 Dia. Sgl
.....	5MC52037004010	Output Shaft/Foll Whl 10 Hole 1/4 Dia. Sgl
.....	5MC52042004012	Output Shaft/Foll Whl 12 Hole 1/4 Dia. Sgl
.....	5MC52050004006	Output Shaft/Foll Whl 6 Hole 9/16 Dia. Dbl
.....	5MC52049004006	Output Shaft/Foll Whl 6 Hole 7/16 Dia. Dbl
.....	5MC52048004008	Output Shaft/Foll Whl 8 Hole 7/16 Dia. Dbl
.....	5MC52047004010	Output Shaft/Foll Whl 10 Hole 7/16 Dia. Dbl
.....	5MC52046004010	Output Shaft/Foll Whl 10 Hole 1/4 Dia. Dbl
.....	5MC52051004012	Output Shaft/Foll Whl 12 Hole 1/4 Dia. Dbl
4 .....	_____	"Cam, (Specify Number Of Stops And "
.....	_____	"Index Time, Contact Camco For "
.....	_____	"Assistance, Order In Matched Sets)"
5 .....	5MB52029003002	"Cart, Output Lg"
6 .....	5MB52019003002	"Cart, Input Ecc "
7 .....	5MA52057000000	Bore Plug 2.756
8 .....	95A33040030000	Shcs M5 X 10
9 .....	84D07329560000	Oil Seal C/R 17754
10 .....	5MA52009018800	Shim Outp .002 Tk
.....	5MA52009028800	Shim Outp .005 Tk
.....	5MA52009038800	Shim Outp .010 Tk
.....	5MA52009048800	Shim Outp .003 Tk
11 .....	86D07328390022	Brg Cup Lm102910
12 .....	86D07328390021	Brg Cone Lm 102949
13 .....	95A33040030000	Shcs M5 X 10
14 .....	86D07328200021	Brg Cone L45449
15 .....	86D07328200022	Brg Cup L45410
* .....	5MB52020003002	"Cart, Output Sm "
17 .....	5MA52010018800	Shim Outp .002 Tk
.....	5MA52010028800	Shim Outp .005tk
.....	5MA52010038800	Shim Outp .010 Tk
.....	5MA52010048800	Shim Outp .003 Tk
18 .....	95A33042120000	Sss M4 X 8 Lg Cone Point
.....	95A33042050000	Sss M3 X 8 Lg Cone Point
19 .....	82A49590000000	Cam Follower 1/4 Dia
.....	82A49591000000	Cam Follower 7/16 Dia
.....	82A49592000000	Cam Follower 9/16 Dia
20 .....	86D07328120021	Bearing Cone Lm11949
21 .....	86D07328120022	Bearing Cup Lm11910
22 .....	5MA52011018800	Shim Inp .002 Tk
.....	5MA52011028800	Shim Inp .005 Tk
.....	5MA52011038800	Shim Inp .010 Tk
.....	5MA52011048800	Shim Inp .003 Tk
23 .....	95A51911110000	Bhcs M5 X 12
24 .....	84D07329480000	Oil Seal C/R 7440
25 .....	84D07329550000	Oil Seal C/R 11067 (FOR DBL)
.....	5MA52057000000	BORE PLUG 2.756 (FOR SGL)
26 .....	M05K125	Key Metric
27 .....	M08K138	Key 8 X 7mm X 1.38 Lg
28 .....	95A33002140000	Plug .12-27 Npt Flush
29 .....	5MA52182000000	"Spacer, Cam "
30 .....	M06K162	KEY 6MM SQ X 1.62 LG
31 .....	_____	Not Used On 50 Rgd/rgs
32 .....	99A44547180000	Service Manual Miniatures
33 .....	99A44547010000	General Service Manual

***PARTS LIST FOR 70RGD INDEX DRIVE (STANDARD CONFIGURATION)***

1 .....	7MG60152001002	Housing
2 .....	7MB60190007002	"Shaft, Input"
3 .....	7MB60253004006	Output Shaft/Foll Whl 6 Hole 3/4 Dia.
.....	7MB60254004006	Output Shaft/Foll Whl 6 Hole 5/8 Dia.
.....	7MB60255004008	Output Shaft/Foll Whl 8 Hole 5/8 Dia.
.....	7MB60256004010	Output Shaft/Foll Whl 10 Hole 5/8 Dia.
.....	7MB60268004012	Output Shaft/Foll Whl 12 Hole 7/16 Dia.
4 .....	_____	"Cam, (Specify Number Of Stops And "
.....	_____	"Index Time, Contact Camco For "
.....	_____	"Assistance, Order In Matched Sets)"
5 .....	7MB60176003002	Cap Output Lg
6 .....	7MB60164003002	Cart Input Ecc
7 .....	7MB60194002002	Cover
8 .....	95A33040040000	S.H.C.S. M5 X 12
9 .....	84C60165030000	Oil Seal C/R 25420
10 .....	7MA60180018800	Shim Outp .002 Tk
.....	7MA60180028800	Shim Outp .005 Tk
.....	7MA60180038800	Shim Outp .010 Tk
11-12 .....	86D07328560013	BRG ASSY TIMKEN 32013X 90KA1
13 .....	95A33040040000	S.H.C.S. M5 X 12
14 .....	86D07328170021	Brg Cone 07100
15 .....	86D07328170022	Brg Cup 07196
16 .....	7MB60177003002	Cap Output Sm
17 .....	7MA60181018800	Shim Outp Sm .002
.....	7MA60181028800	Shim Outp Sm .005
.....	7MA60181038800	Shim Outp Sm .010
18 .....	95A33042140000	Sss Cone Pt M4x12
.....	95A33042220000	Sss Cone Pt M5 X 12 Lg
19 .....	82A49591000000	Follower 7/32 Dia.
.....	82C33150010003	Follower 5/8 Dia.
.....	82C33150020003	Follower 3/4 Dia.
20 .....	86D07328230021	Brg Cone Timken Lm 67048
21 .....	86D07328230022	Brg Cup Timken Lm 67010
22 .....	26B01052018800	Shim Inp .002 Thk
.....	26B01052028800	Shim Inp .005 Thk
.....	26B01052038800	Shim Inp .010 Thk
23 .....	95A51911100000	Bhcs M5 X 10 Lg
24 .....	84C60165010000	Oil Seal C/R 9715
25 .....	84C60165020000	Oil Seal C/R 11610
26 .....	M06K150	Key 6mm Sq X 1.50 Lg F.S.
27 .....	025K187	Key .250 Sq. X 1.87 F.S.
28 .....	95A33002130000	Plug .25-18 Npt Flush
29 .....	7MA60192009000	Spacer Cam
30 .....	_____	Not Used On 70rgd
31 .....	_____	Not Used On 70rgd/rgs
32 .....	99A44547180000	Service Manual Miniatures
33 .....	99A44547010000	General Service Manual

## PARTS LIST FOR 70RGS INDEX DRIVE (STANDARD CONFIGURATION)

1 .....	7MG60152001002	Housing
2 .....	7MB60190007002	"Shaft, Input"
3 .....	7MB60257004006	Output Shaft/Foll Whl 6 Hole 3/4 Dia. Sgl
.....	7MB60258004006	Output Shaft/Foll Whl 6 Hole 5/8 Dia. Sgl
.....	7MB60259004008	Output Shaft/Foll Whl 8 Hole 5/8 Dia. Sgl
.....	7MB60260004010	Output Shaft/Foll Whl 10 Hole 5/8 Dia. Sgl
.....	7MB60262004006	Output Shaft/Foll Whl 6 Hole 3/4 Dia. Dbl
.....	7MB60263004006	Output Shaft/Foll Whl 6 Hole 5/8 Dia. Dbl
.....	7MB60264004008	Output Shaft/Foll Whl 8 Hole 5/8 Dia. Dbl
.....	7MB60265004010	Output Shaft/Foll Whl 10 Hole 5/8 Dia. Dbl
4 .....	_____	"Cam, (Specify Number Of Stops And "
.....	_____	"Index Time, Contact Camco For "
.....	_____	"Assistance, Order In Matched Sets)"
5 .....	7MB60176003002	Cap Output Lg
6 .....	7MB60164003002	Cart Input Ecc
7 .....	7MB60194002002	Cover
8 .....	95A33040040000	S.H.C.S. M5 X 12
9 .....	84C60165030000	Oil Seal C/R 25420
10 .....	7MA60180018800	Shim Outp .002 Tk
.....	7MA60180028800	Shim Outp .005 Tk
.....	7MA60180038800	Shim Outp .010 Tk
11-12 .....	86D07328560013	BRG ASSY TIMKEN 32013X 90KA1
13 .....	95A33040040000	S.H.C.S. M5 X 12
14 .....	86D07328170021	Brg Cone 07100
15 .....	86D07328170022	Brg Cup 07196
16 .....	7MB60177003002	Cap Output Sm
17 .....	7MA60181018800	Shim Outp Sm .002
.....	7MA60181028800	Shim Outp Sm .005
.....	7MA60181038800	Shim Outp Sm .010
18 .....	95A33042140000	Sss Cone Pt M4x12
.....	95A33042220000	Sss Cone Pt M5 X 12 Lg
19 .....	82A49591000000	Follower 7/32 Dia.
.....	82C33150010003	Follower 5/8 Dia.
.....	82C33150020003	Follower 3/4 Dia.
20 .....	86D07328230021	Brg Cone Timken Lm 67048
21 .....	86D07328230022	Brg Cup Timken Lm 67010
22 .....	26B01052018800	Shim Inp .002 Thk
.....	26B01052028800	Shim Inp .005 Thk
.....	26B01052038800	Shim Inp .010 Thk
23 .....	95A51911100000	Bhcs M5 X 10 Lg
24 .....	84C60165010000	Oil Seal C/R 9715
25 .....	84C60165020000	Oil Seal C/R 11610 (FOR DBL OUTPUT ONLY)
26 .....	M06K150	Key 6mm Sq X 1.50 Lg F.S.
27 .....	025K187	Key .250 Sq. X 1.87 F.S.
28 .....	95A33002130000	Plug .25-18 Npt Flush
29 .....	7MA60192009000	Spacer Cam
30 .....	M08K200	KEY 8X7MM X2LG
31 .....	_____	Not Used On 70rgd/rgs
32 .....	99A44547180000	Service Manual Miniatures
33 .....	99A44547010000	General Service Manual

**PARTS LIST FOR 80RGD INDEX DRIVE (STANDARD CONFIGURATION)**

1 .....	8MG60210001002	Housing
2 .....	8MB60757007002	Shaft Input (W/O Reducer)
.....	8MC60917007002	Shaft Input (For 180sm)
3 .....	8MC60827004006	Output Shaft/Foll Whl 6 Holes 7/8 Dia.
.....	8MC60828004008	Output Shaft/Foll Whl 8 Holes 3/4 Dia.
.....	8MC60829004010	Output Shaft/Foll Whl 10 Holes 5/8 Dia.
.....	8MC60830004012	Output Shaft/Foll Whl 12 Holes 9/36 Dia.
4 .....	_____	“Cam, (Specify Number Of Stops And “
.....	_____	“Index Time, Contact Camco For “
.....	_____	“Assistance, Order In Matched Sets)”
5 .....	8MB60772003002	Cap Output Lg
6 .....	7MB60164003002	Cart Input Ecc
7 .....	8MA63280002002	Cover
8 .....	95A33040040000	S.H.C.S. M5 X 12
9 .....	84C60165040000	Oil Seal C/R 31510
10 .....	8MB60776018800	Shim Outp .002 Tk
.....	8MB60776028800	Shim Outp .005 Tk
.....	8MB60776038800	Shim Outp .010 Tk
11-12 .....	86D07328650013	Brg Assy 32016x 92ka1
13 .....	95A33004180000	Shcs M6 X 16 Lg
14 .....	86D07328350021	Brg Cone Lm 501349
15 .....	86D07328350022	Brg Cup Lm501310
16 .....	8MB60764003002	Cap Lo Output
17 .....	8MA60768018800	Shim Outp .002 Tk
.....	8MA60768028800	Shim Outp .005 Tk
.....	8MA60768038800	Shim Outp .010 Tk
18 .....	95A33042230000	Sss Cone Pt M5 X16
.....	95A33042140000	Sss Cone Pt M4 X 12
19 .....	82C33150020003	Cam Follower 3/4 Dia.
.....	82C33150030003	Cam Follower 7/8 Dia.
.....	82C33150010003	Cam Follower 5/8 Dia.
20 .....	86D07328170021	Brg Cone 07100
21 .....	86D07328170022	Brg Cup 07196
22 .....	26B01052018800	Shim Inp .002 Thk
.....	26B01052028800	Shim Inp .003 Thk
.....	26B01052038800	Shim Inp .010 Thk
23 .....	95A51911080000	Bhcs M4 X12
24 .....	84C60165010000	Oil Seal C/R 9715
25 .....	84C60165050000	Oil Seal C/R 14725
26 .....	M08K200	Key 8x7mm X2lg
27 .....	025K212	Key .250sq X 2.12 Lg
28 .....	95A33002130000	Plug .25-18 Npt Flush
29 .....	8MA60758009000	Spacer Cam
30 .....	_____	Not Used On 80rgd
31 .....	8MC60918009100	Mounting Plate (For 180sm)
32 .....	99A44547180000	Service Manual Miniatures
33 .....	99A44547010000	General Service Manual



## PARTS LIST FOR 80RGS INDEX DRIVE (STANDARD CONFIGURATION)

1 .....	8MG60210001002	Housing
2 .....	8MB60757007002	Shaft Input (W/O Reducer)
.....	8MC60917007002	Shaft Input (For 180sm)
3 .....	8MC60831004006	"Output Shaft/Foll Whl (For 6h24, 6h28) Sgl"
.....	8MC60832004006	Output Shaft/Foll Whl 8h24 Sgl
.....	8MC60833004010	Output Shaft/Foll Whl 10h20 Sgl
.....	8MC60834004012	Output Shaft/Foll Whl 12h18 Sgl
.....	8MC60835004006	"Output Shaft/Foll Whl (For 6h24, 6h28) Dbl"
.....	8MC60836004008	Output Shaft/Foll Whl 8h24 Dbl
.....	8MC60837004008	Output Shaft/Foll Whl 10h20 Dbl
.....	8MC60838004012	Output Shaft/Foll Whl 12h18 Dbl
4 .....	_____	"Cam, (Specify Number Of Stops And "
.....	.....	"Index Time, Contact Camco For "
.....	.....	"Assistance, Order In Matched Sets)"
5 .....	8MB60772003002	Cap Output Lg
6 .....	7MB60164003002	Cart Input Ecc
7 .....	8MA63280002002	Cover
8 .....	95A33040040000	S.H.C.S. M5 X 12
9 .....	84C60165040000	Oil Seal C/R 31510
10 .....	8MB60776018800	Shim Outp .002 Tk
.....	8MB60776028800	Shim Outp .005 Tk
.....	8MB60776038800	Shim Outp .010 Tk
11-12 .....	86D07328650013	Brg Assy 32016x 92ka1
13 .....	95A33004180000	Shcs M6 X 16 Lg
14 .....	86D07328350021	Brg Cone Lm 501349
15 .....	86D07328350022	Brg Cup Lm501310
16 .....	8MB60764003002	Cap Lo Output
17 .....	8MA60768018800	Shim Outp .002 Tk
.....	8MA60768028800	Shim Outp .005 Tk
.....	8MA60768038800	Shim Outp .010 Tk
18 .....	95A33042230000	Sss Cone Pt M5 X16
.....	95A33042140000	Sss Cone Pt M4 X 12
19 .....	82C33150020003	Cam Follower 3/4 Dia.
.....	82C33150030003	Cam Follower 7/8 Dia.
.....	82C33150010003	Cam Follower 5/8 Dia.
20 .....	86D07328170021	Brg Cone 07100
21 .....	86D07328170022	Brg Cup 07196
22 .....	26B01052018800	Shim Inp .002 Thk
.....	26B01052028800	Shim Inp .003 Thk
.....	26B01052038800	Shim Inp .010 Thk
23 .....	95A51911080000	Bhcs M4 X12
24 .....	84C60165010000	Oil Seal C/R 9715
25 .....	84C60165050000	Oil Seal C/R 14725 (For Dbl Output Only)
26 .....	M08K200	Key 8x7mm X2lg
27 .....	025K212	Key .250sq X 2.12 Lg
28 .....	95A33002130000	Plug .25-18 Npt Flush
29 .....	8MA60758009000	Spacer Cam
30 .....	M08K200	Key 8x7mm X2lg
31 .....	8MC60918009100	Mounting Plate (For 180sm)
32 .....	99A44547180000	Service Manual Miniatures
33 .....	99A44547010000	General Service Manual



A **DOVER** COMPANY

**Automation**  
**Robohand FERGUSON**  
**CAMCO**

CAMCO & FERGUSON Products  
1444 South Wolf Road  
Wheeling, IL 60090  
USA  
ph: 847-459-5200  
toll-free: 800-645-5200  
fax: 847-459-3064  
camco@destaco.com

*ISO 9001:2000 Registered*

DE-STA-CO Headquarters  
Auburn Hills, Michigan USA  
248-836-6700  
marketing@destaco.com

[www.destaco.com](http://www.destaco.com)

DE-STA-CO Europe  
Germany  
+49-6171-705-0  
europe@destaco.com

DE-STA-CO Asia  
Thailand  
+66-2-326-0812  
info@destaco.com

DE-STA-CO South America  
Brazil  
0800-124070  
samerica@destaco.com

This publication is for information purposes only and should not be considered a binding description of the product except is confirmed in writing by Industrial Motion Control, LLC/DE-STA-CO

© DE-STA-CO 2004-2014  
All rights reserved  
Printed in U.S.A.  
SKU 0064 (6/99)  
99A44547180000