

## Service Manual

# ROBOHAND | Feed Escapements

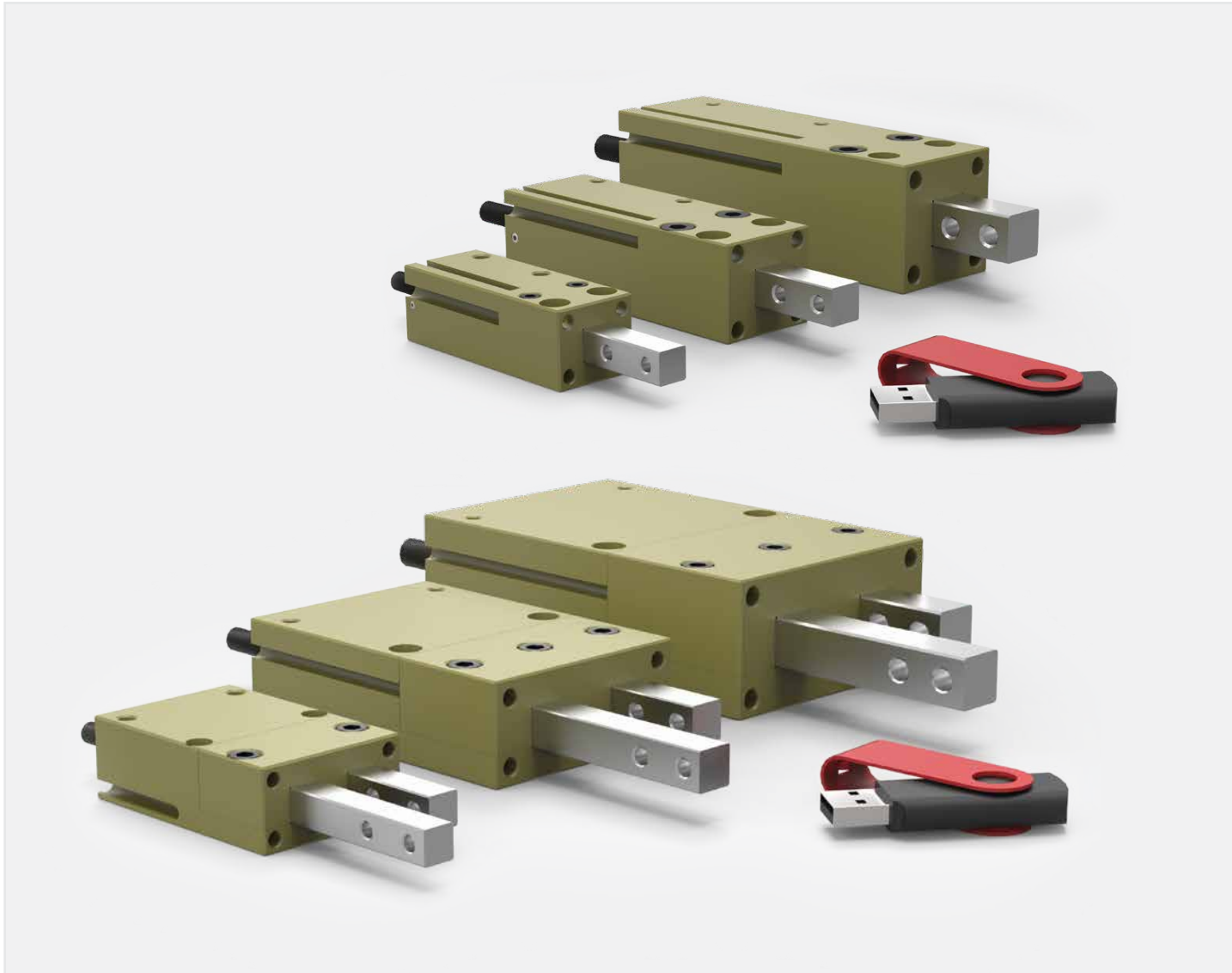

**WARNING:** This is a controlled document. It is your responsibility to deliver this information to the end user of the Destaco Robohand product. Failure to deliver this could result in your liability for injury to the user or damage to the machine. For copies of this manual, call your Customer Service Representative at 1.248.836.6700

# RFE SERIES

## Feed Escapements | Maintenance and Assembly Procedure

Item Qty	Name
01	1 Body
02	2 Finger
03	2 Piston
04	2 Cap
05	1 Cover, Finger
07	1 Shuttle Slug
30	2 Stop, Screw
32	2 Jam Nut
33	2 Dowel Pin
34	2 SSS, Cup Point
40	2 Magnet, Ring

**NOTE:** Contact the Robohand Sales Department for a complete spare parts list with order numbers and prices.

### Assembly Procedure

- 1) Super bond magnet to piston.
- 2) Lubricate u-cup and install into body.
- 3) Orient fingers and slide into body.
- 4) Attach pistons to fingers in bores, using spanner.
- 5) Install caps, o-rings and adjustment screws into body with retainner ring.
- 6) Lock in caps by tightening set screws.
- 7) Press dowel pins in finger cover.
- 8) Place shuttle slug in position.
- 9) Install finger cover.

### Stroke Adjustment Procedure

- 1) The stroke of each finger can be adjusted by its respective set screw (#30).
- 2) To reduce the stroke of the desired finger on retraction, tighten its respective set screw. note: stroke can only be reduced on retraction; (the finger will always extend the same distance away from the body). Stroke cannot be increased more than the value stated in the catalog.

**SK** Seal Repair Kit Order #s  
See Product Data Sheets

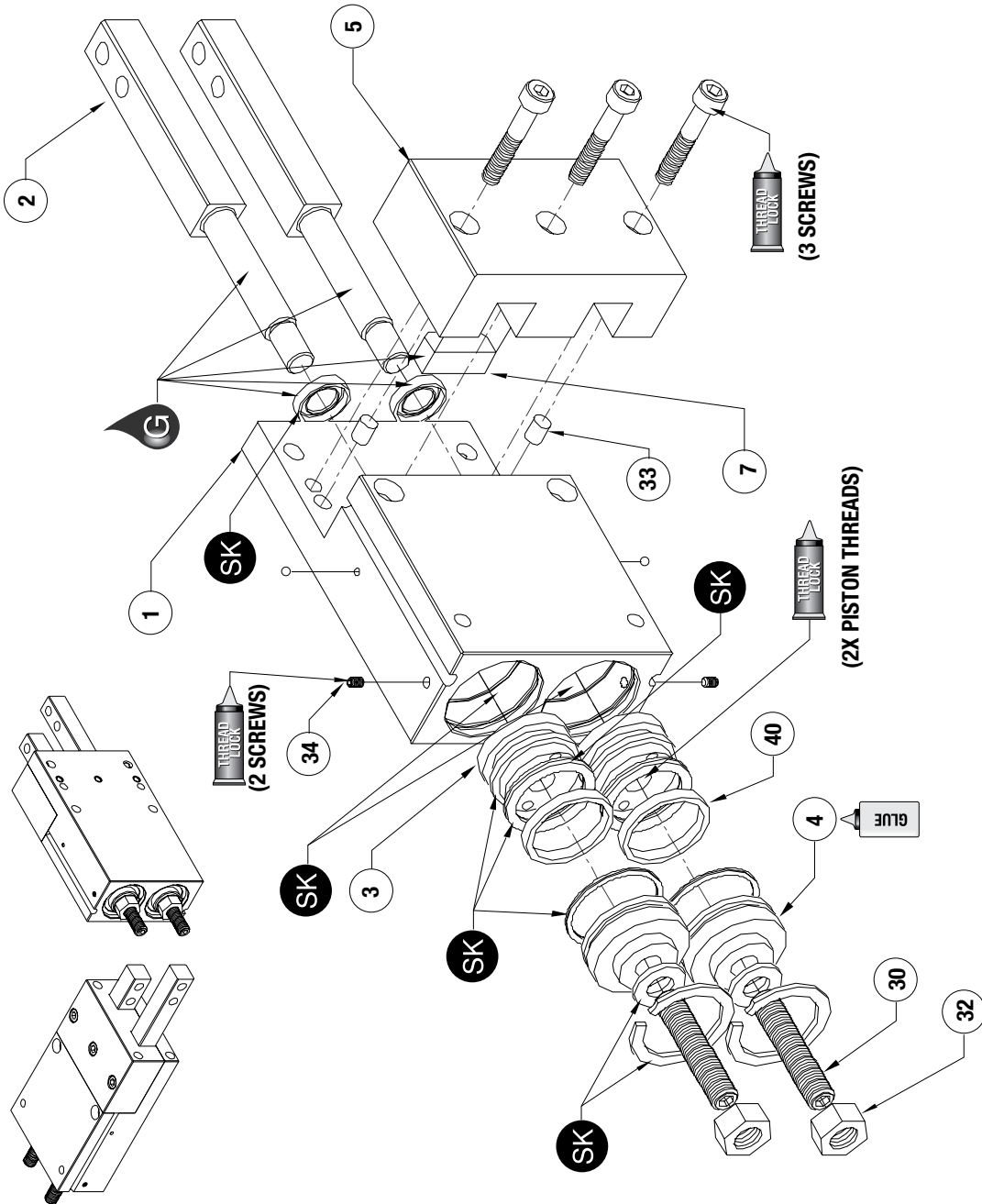

<b>SK</b>	Seal Kit Items
	Thread Locker
	Krytox™ Lubricant
	Lightweight Machine Oil
	Super Bonder Glue
	Teflon™ Based Grease
	Third Angle Projection

Item	Qty	Name
01	1	Body
02	2	Finger
03	2	Piston
04	2	Cap
05	1	Cover, Finger
07	1	Shuttle Slug
30	2	Stop, Screw
32	2	Jam Nut
33	2	Dowel Pin
34	2	SSS, Cup Point
40	2	Magnet, Ring

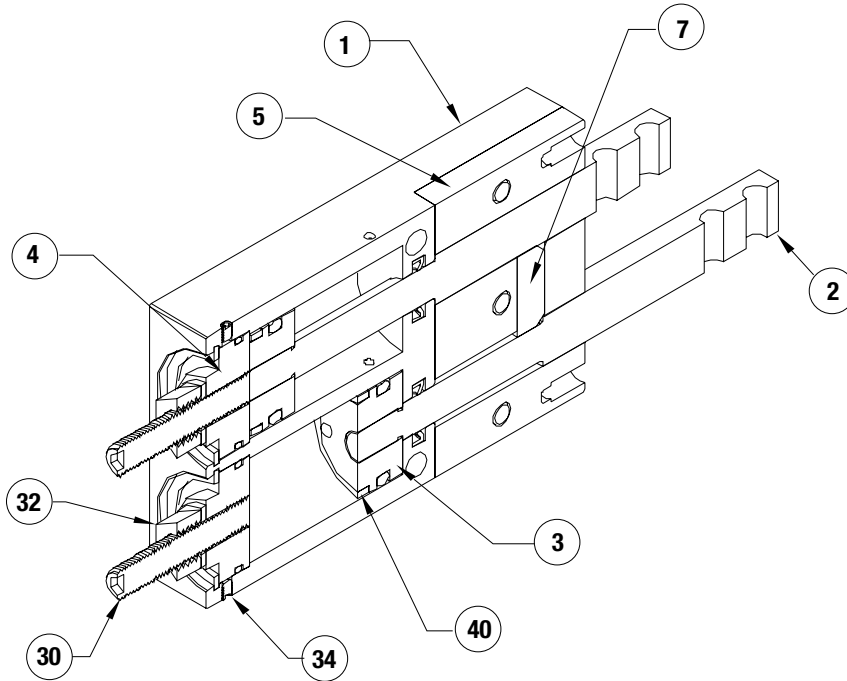

**NOTE:** Contact the Robohand Sales Department for a complete spare parts list with order numbers and prices.

### Accessory Installation & Adjustment Instructions

#### Sensor Installation

1. Install sensors (2) in profile slots of escapement body (1) as shown.
2. Set sensors with integrated setscrew.

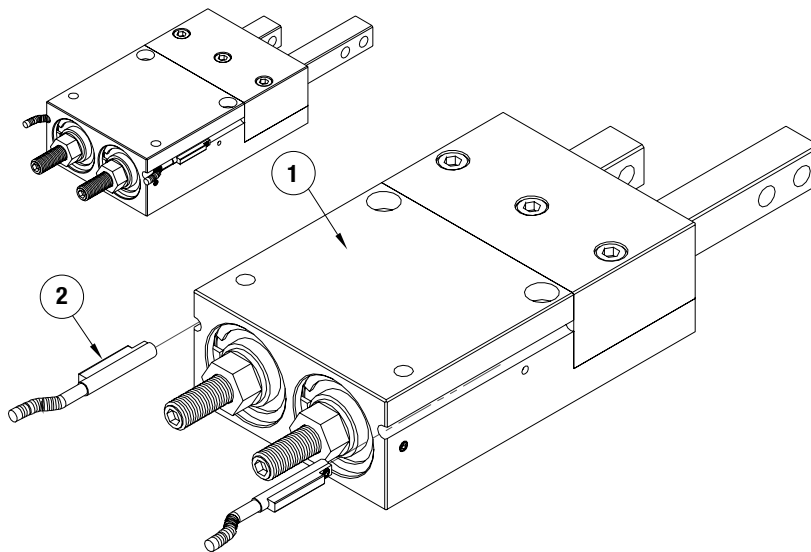

Seal Kit Items



Thread Locker



Krytox™ Lubricant



Lightweight Machine Oil



Teflon® Based Grease



Super Bonder



Third Angle Projection

# RN SERIES

## Feed Escapements | Maintenance and Assembly Procedure

Item Qty	Name
01 1	Body
02 1	Finger
03 1	Piston
04 1	Cap
05 1	Cover, Finger
30 1	Screw, Stop
31 1	Jam Nut
32 2	Dowel Pin
33 1	Sss,Cup ,Point
40 1	Magnet, Ring

**NOTE:** Contact the Robohand Sales Department for a complete spare parts list with order numbers and prices.

### Assembly Procedure

- 1) Super bond magnet to piston.
- 2) Lubricate u-cup and install into body.
- 3) Orient finger and slide into body.
- 4) Attach piston to finger in bore, using spanner.
- 5) Install cap, o-rings, and adjustment screw into body with retainer ring.
- 6) Lock in cap by tightening set screw.
- 7) Press dowel pins in finger cover.
- 8) Install finger cover.

### Stroke Adjustment Procedure

- 1) Stroke can be adjusted by set screw #30.
- 2) To reduce the stroke on retraction, tighten the set screw.

**Note:** stroke can only be reduced on retraction. (the finger will always extend the same distance away from the body.) stroke cannot be increased more than the value stated in the catalog.

**SK Seal Repair Kit Order #'s**  
See Product Data Sheets

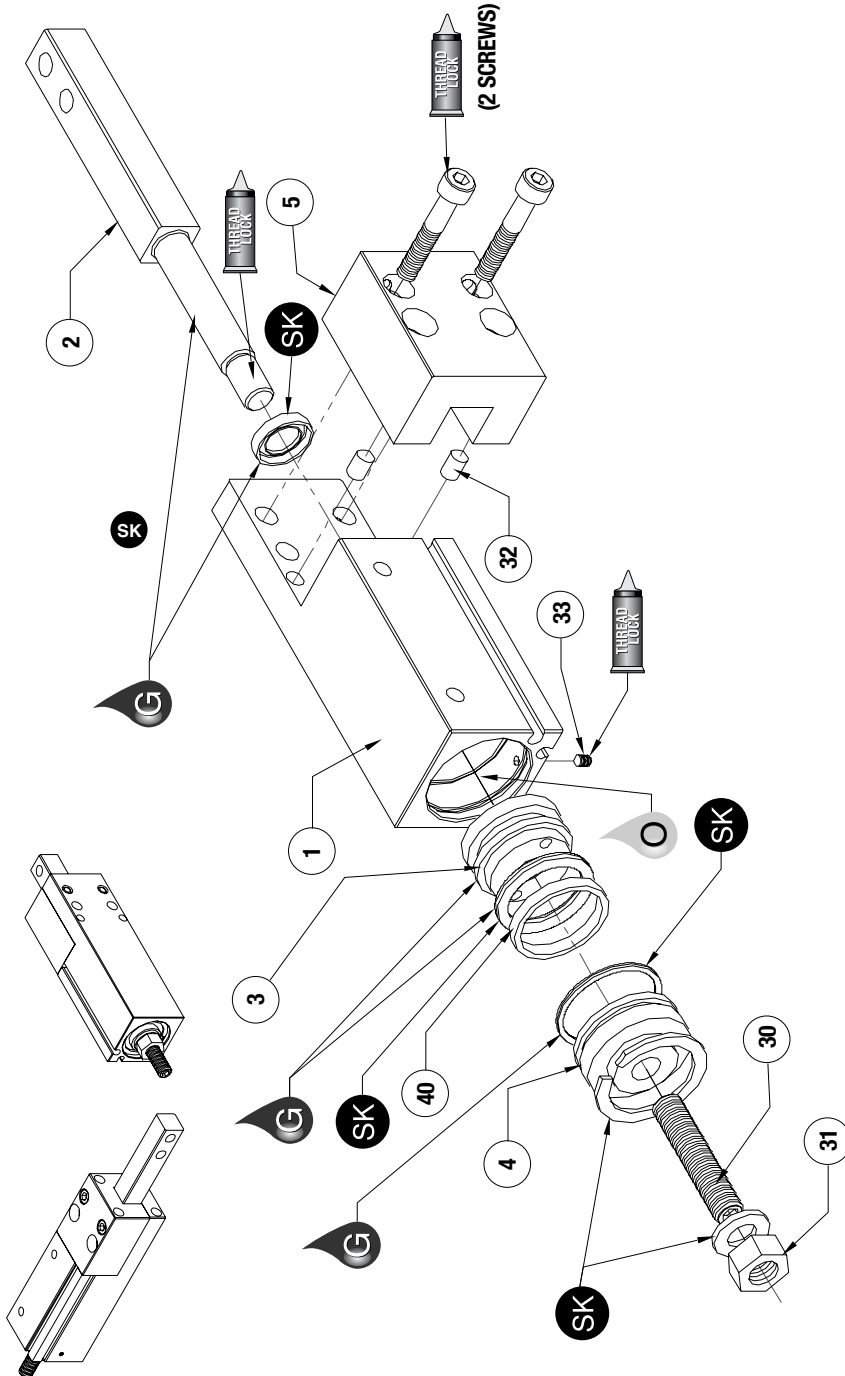

	SK Seal Kit Items
	Thread Locker
	Krytox™ Lubricant
	Lightweight Machine Oil
	Teflon™ Based Grease
	Super Bonder
	Third Angle Projection

Item	Qty	Name
01	1	Body
02	1	Finger
03	1	Piston
04	1	Cap
05	1	Cover, Finger
30	1	Screw, Stop
31	1	Jam Nut
32	2	Dowel Pin
33	1	Sss,Cup Point
40	1	Magnet, Ring

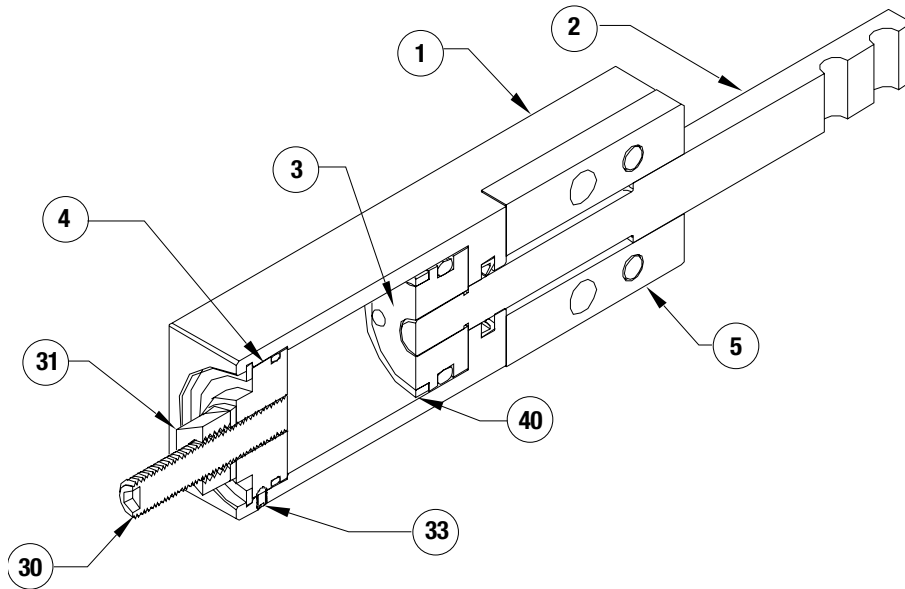

**NOTE:** Contact the Robohand Sales Department for a complete spare parts list with order numbers and prices.

### Accessory Installation & Adjustment Instructions

#### Installation

- 1) Install sensors (2) in profile slots of cylinder body (1) as shown.
- 2) Set sensors with integrated setscrew.

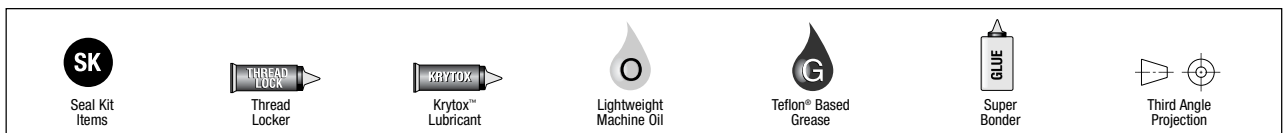
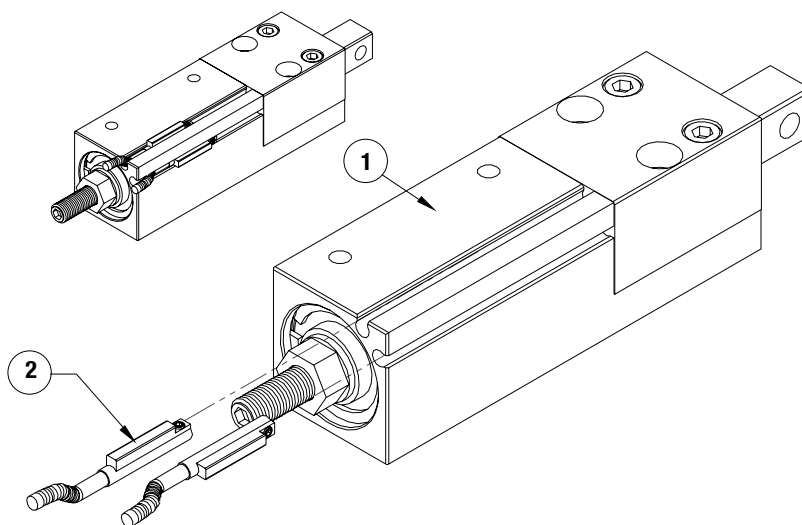

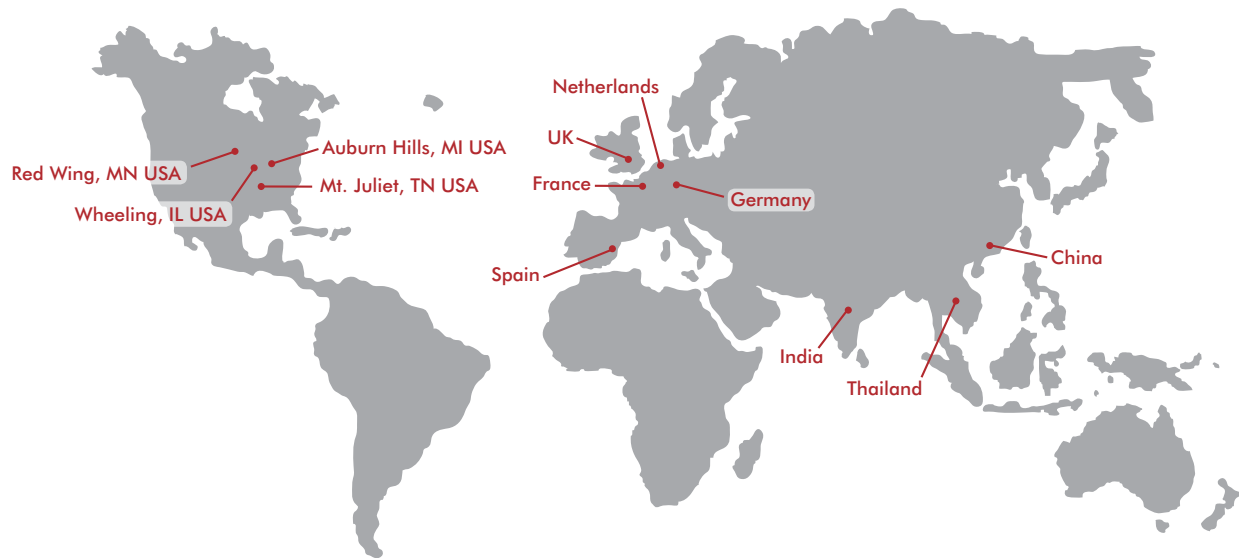

## GLOBAL LOCATIONS

### NORTH AMERICA

#### Corporate Headquarters

Auburn Hills, Michigan  
Toll Free: 1.888.DESTACO  
Marketing: [marketing@destaco.com](mailto:marketing@destaco.com)

#### Global Technology Center

Auburn Hills, Michigan  
Tel: 1.248.836.6700  
Customer Service: [customerservice@destaco.com](mailto:customerservice@destaco.com)

Mt. Juliet, Tennessee  
Tel: 1.888.DESTACO  
Customer Service: [customerservice@destaco.com](mailto:customerservice@destaco.com)

Wheeling, Illinois  
Tel: 1.800.645.5207  
Customer Service: [camco@destaco.com](mailto:camco@destaco.com)

Red Wing, Minnesota (Central Research Laboratories)  
Tel: 651.385.2142  
Customer Service: [sales@centres.com](mailto:sales@centres.com)

### ASIA

Bangkok, Thailand  
Tel: +66-2-326-0812  
Customer Service: [info@destaco.com](mailto:info@destaco.com)

Shanghai, China  
Tel: +86-21-6081-2888  
Customer Service: [china@destaco.com](mailto:china@destaco.com)

Bangalore, India  
Tel: +91-80-41123421-426  
Customer Service: [india@destaco.com](mailto:india@destaco.com)

### EUROPE

Oberursel, Germany  
Tel: +49-6171-705-0  
Customer Service: [europe@destaco.com](mailto:europe@destaco.com)

Sainte Florine, France  
Tel: +33-4-73545001  
Customer Service: [france@destaco.com](mailto:france@destaco.com)

Wolverhampton, United Kingdom  
Tel: +44-1902-797980  
Customer Service: [uk@destaco.com](mailto:uk@destaco.com)

Sant Boi de Llobregat, Spain  
Tel: +34-936361680  
Customer Service: [spain@destaco.com](mailto:spain@destaco.com)

Uithoorn, Netherlands  
Tel: +31-297285332  
Customer Service: [benelux@destaco.com](mailto:benelux@destaco.com)