

Service Manual

ROBOHAND | DPDL Series



WARNING: This is a controlled document. It is your responsibility to deliver this information to the end user of the Destaco Robohand product. Failure to deliver this could result in your liability for injury to the user or damage to the machine. For copies of this manual, call your Customer Service Representative at 1.248.836.6700

DPDL SERIES

Parallel Grippers | Maintenance and Assembly Procedure

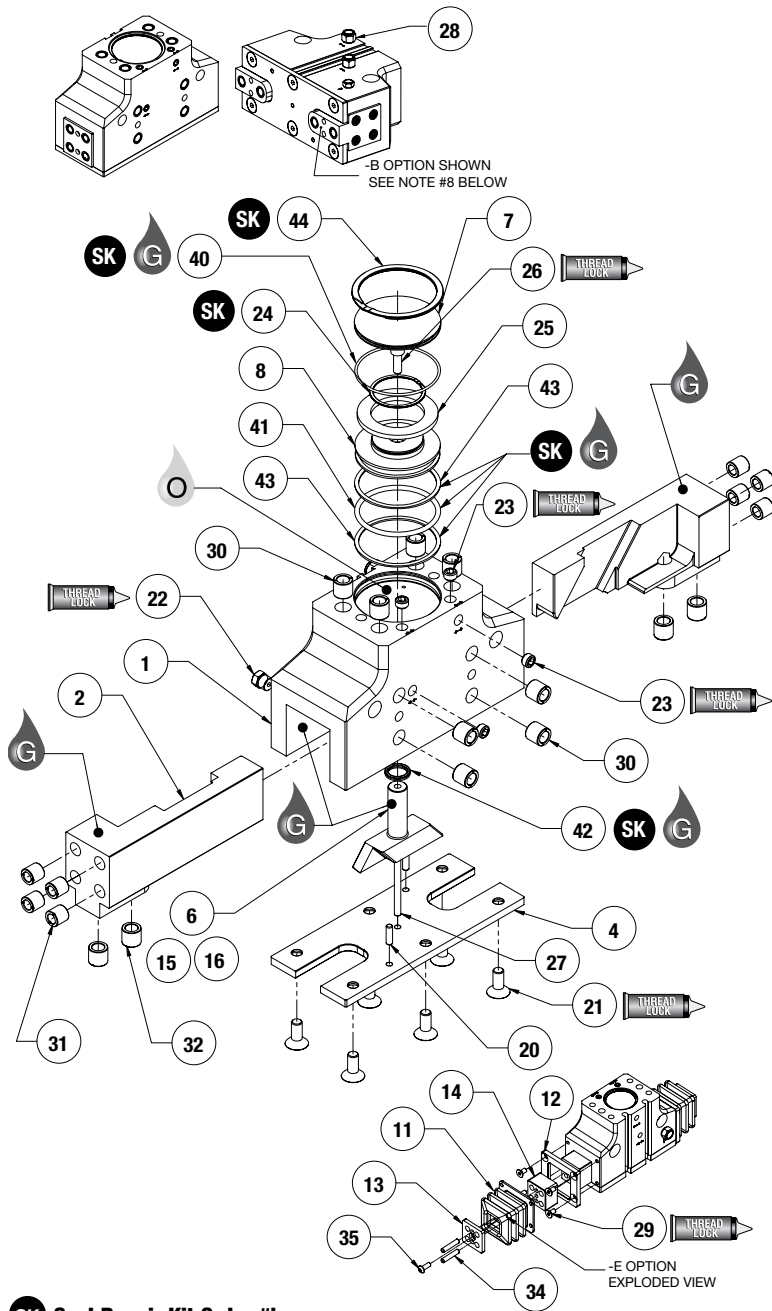

SK Seal Repair Kit Order #'s
See Product Data Sheets

Assembly Procedure:

- 1) Install #23 airport plugs with thread-locker.
- 2) Press pins #20 & #27 into plate #4.
- 3) Install threaded inserts #30, #31, & #32.
- 4) Install #22 vent or plug with thread-locker.
- 5) Mount magnet #25 to piston #8 with retaining ring #24.
- 6) Install #28 metric plumbing fitting adapters.
- 7) Lubricate body #1 (jaw cavity & bores).
- 8) Lubricate & install all seals into body, piston, & cap.

- 9) Sub-assemble the #2 jaws on either side of the #6 shaft wedge with lubrication.
- 10) Insert the jaws and shaft wedge sub-assembly into body.
- 11) Insert piston #8 into the body bore and fasten it to the shaft wedge with Mounting screw #26 using thread locker.
- 12) Install cap #7 into body with retaining ring #44.
- 13) Insert #4 bottom plate with pressed-in pins onto the body and fasten with #21 screws with thread-locker.

-E Option Assembly Procedure:

- 1) Insert pins #34 into the jaw dowel pin holes.
- 2) Place #14 boot spacer over pins
- 3) Fasten boot #11 and flange #12 to body #1 with #29 screws.
- 4) Fasten the spacer cap #13 to the spacer #14 with #35 screw.

Item	Qty	Name
01	1	Body
02	2	Jaw
04	1	Bottom Plate
06*	1	Shaft Wedge
07	1	Cap
08	1	Piston
11	2	Boot
12	2	Boot Flange
13	2	Boot Spacer Cap
14	2	Boot Spacer
15*	1	Shaft
16*	1	Wedge
20	2	Bottom Plate Locating Dowels
21	6	Bottom Plate Screws
22*	1	Breather Vent Plug (Purge)
23	4	Manifold Port Plugs
24	1	Piston Mag. Ret. Ring
25	1	Piston Magnet
26	1	Piston Mounting Screw
27	1	Shaft guide dowel pin
28*	2	Plumbing Fitting - Adapter - 1/8NPT male to 1/8BSPP female
29	8	Boot Flange Mounting Screws
30*	8	Threaded Inserts (Body)
31*	8	Threaded Inserts (Jaw - End Mount)
32*	4	Threaded Inserts (Jaw - Bottom Mount "-B" option only)
34	4	Boot Spacer Dowel Pins
35*	2	Boot Spacer Mtg Screws
40	1	Cap O-ring
41	1	Piston O-ring
42	1	U-cup
43*	2	Piston Teflon Ring
44	1	Cap Ret. Ring

NOTES:*

- 1) Contact the RoboHand Sales Department for a complete spare parts list with order numbers and prices.
- 2) Item #30 is for size -175 and -250 only.
- 3) Item #31 and #32 are for size -250 only.
- 4) Item #22 Breather vent plug is a set screw plug for sizes -047 & -056.
- 5) Item #43 is for size -175 and -250 only.
- 6) Item #28 is for metric size -175M and -250M only.
- 7) Item #35 is for sizes -088 thru -250 only.
- 8) End-of-jaw mounting holes on -B option are supplied plugged to prevent debris from entering the gripper. These set screws can be removed for customer finger mounting. It is recommend that all unused holes be plugged for the same reason.
- 9) Item #6 does not pertain to size -250
- 10) Items #15 & 16 are for size -250 only

Parallel Grippers | Maintenance and Assembly Procedure

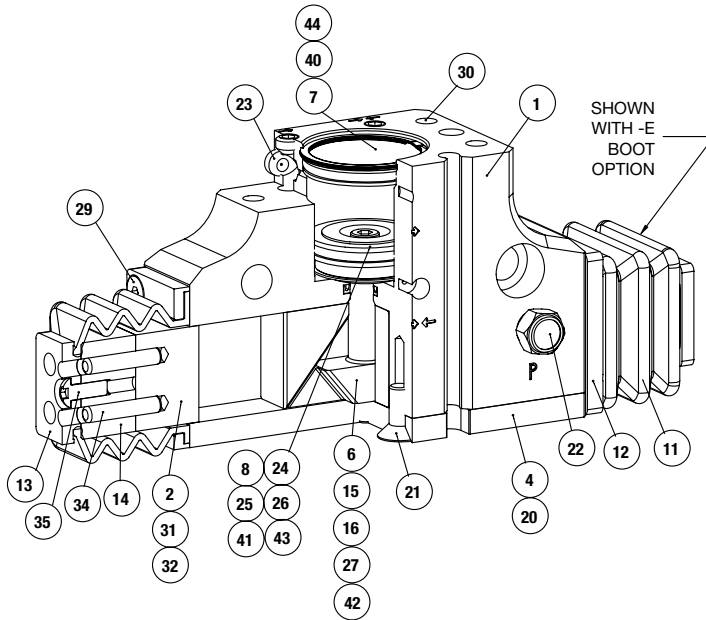

Item	Qty	Name
01	1	Body
02	2	Jaw
04	1	Bottom Plate
06*	1	Shaft Wedge
07	1	Cap
08	1	Piston
11	2	Boot
12	2	Boot Flange
13	2	Boot Spacer Cap
14	2	Boot Spacer
15*	1	Shaft
16*	1	Wedge
20	2	Bottom Plate Locating Dowels
21	6	Bottom Plate Screws
22*	1	Breather Vent Plug (Purge)
23	4	Manifold Port Plugs
24	1	Piston Mag. Ret. Ring
25	1	Piston Magnet
26	1	Piston Mounting Screw
27	1	Shaft guide dowel pin
28*	2	Plumbing Fitting Adapter - 1/8NPT male to 1/8BSPP female
29	8	Boot Flange Mounting Screws
30*	8	Threaded Inserts (Body)
31*	8	Threaded Inserts (Jaw - End Mount)
32*	4	Threaded Inserts (Jaw - Bottom Mount "-B" option only)
34	4	Boot Spacer Dowel Pins
35*	2	Boot Spacer Mtg Screws
40	1	Cap O-ring
41	1	Piston O-ring
42	1	U-cup
43*	2	Piston Teflon Ring
44	1	Cap Ret. Ring

NOTES:*

- 1) Contact the Robohand Sales Department for a complete spare parts list with order numbers and prices.
- 2) Item #30 is for size -175 and -250 only.
- 3) Item #31 and #32 are for size -250 only.
- 4) Item #22 breather vent plug is a set screw plug for sizes -047 & -056.
- 5) Item #43 is for size -175 and -250 only.
- 6) Item #28 is for metric size -175M and -250M only.
- 7) Item #35 is for sizes -088 thru -250 only.
- 8) Item #6 does not pertain to size -250
- 9) Items #15 & 16 are for size -250 only

Accessory Installation & Adjustment Instructions

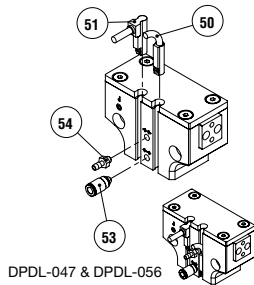

DPDL-047 & DPDL-056

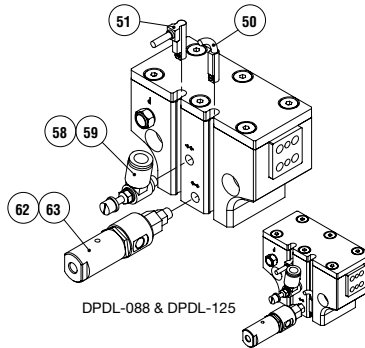

DPDL-088 & DPDL-125

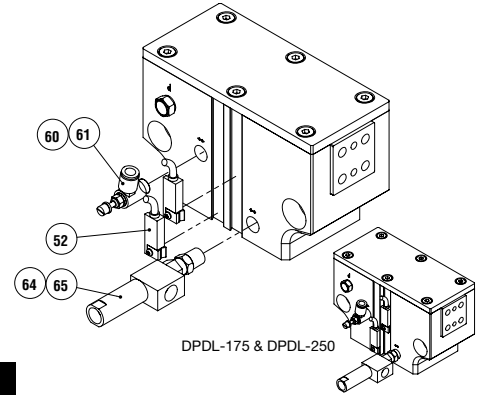

DPDL-175 & DPDL-250

Item	Qty	Name
50	1 or 2	Magneto Resistive Sensor (short barrel) w/Qk. Disconnect
51	1 or 2	Magneto Resistive Sensor (90° barrel) w/Qk. Disconnect
52	1 or 2	Magneto Resistive Sensor (12mm Dovetail) w/Qk. Disconnect
53	1, 2, or 3	Plumbing Fitting - M3 male to 3mm OD Push-in Style
54	1, 2, or 3	Plumbing Fitting - M3 male to 2mm ID Barb Style
58	1 or 2	Adj. Flow Control (Imperial) #10-32 elbow - 1/4" OD Push-in Style
59	1 or 2	Adj. Flow Control (Metric) M5 elbow - 6mm OD Push-in Style
60	1 or 2	Adj. Flow Control (Imperial) 1/8 NPT elbow - 1/4" OD Push-in Style
61	1 or 2	Adjustable Flow Control (Metric) G1/8 elbow - 6mm OD Push-in Style
62	1	Fail Safe Valve (Imperial) #10-32
63	1	Fail Safe Valve (Metric) M5
64	1	Fail Safe Valve (Imperial) 1/8 NPT
65	1	Fail Safe Valve (Metric) G1/8 (1/8 BSPP)

NOTE: Other Plumbing Fittings are available for each size - Consult Factory

Magneto-Resistive Sensors:

- 1) Insert sensors #50 or #51 from either end of the profile slots and set the sensor with the integrated screw.
- 2) Insert sensor #52 into the dovetail slot at any point and set the sensor with the integrated screw & locking shoe.

Plumbing Fittings:

- 1) M3 plumbing fittings #53 & #54 can be used in any airport or purge/scavenge port.
- 2) Flow controls can be inserted and used in any open or closed airport to help control the stroke actuation.
- 3) Fail-safe valve can be used in either the open or closed airport to help limit the possibility of dropping the part if air pressure is lost.

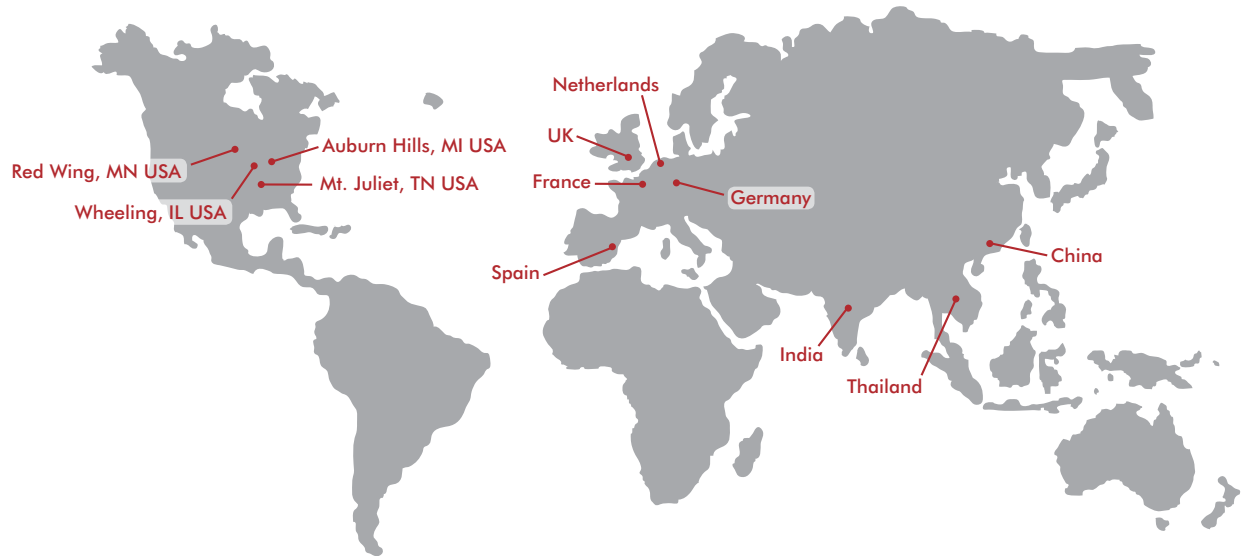

GLOBAL LOCATIONS

NORTH AMERICA

Corporate Headquarters

Auburn Hills, Michigan
Toll Free: 1.888.DESTACO
Marketing: marketing@destaco.com

Global Technology Center

Auburn Hills, Michigan
Tel: 1.248.836.6700
Customer Service: customerservice@destaco.com

Mt. Juliet, Tennessee
Tel: 1.888.DESTACO
Customer Service: customerservice@destaco.com

Wheeling, Illinois
Tel: 1.800.645.5207
Customer Service: camco@destaco.com

Red Wing, Minnesota (Central Research Laboratories)
Tel: 651.385.2142
Customer Service: sales@centres.com

ASIA

Bangkok, Thailand
Tel: +66-2-326-0812
Customer Service: info@destaco.com

Shanghai, China
Tel: +86-21-6081-2888
Customer Service: china@destaco.com

Bangalore, India
Tel: +91-80-41123421-426
Customer Service: india@destaco.com

EUROPE

Oberursel, Germany
Tel: +49-6171-705-0
Customer Service: europe@destaco.com

Sainte Florine, France
Tel: +33-4-73545001
Customer Service: france@destaco.com

Wolverhampton, United Kingdom
Tel: +44-1902-797980
Customer Service: uk@destaco.com

Sant Boi de Llobregat, Spain
Tel: +34-936361680
Customer Service: spain@destaco.com

Uithoorn, Netherlands
Tel: +31-297285332
Customer Service: benelux@destaco.com