



PGM/GTB Series

Camco Servo Positioning Solutions

Destaco offers three series of high performance servo positioners ranging from light to heavy duty. All of the series feature large center thru-holes and zero backlash mechanisms.

The PGM Series is used for small high speed positioning and provides sub-positioning on large servo positioning applications.

The GTB series is compact and lightweight servo positioner, offered in four sizes and can be used for a wide range of applications.











Product Highlights/Options

- Freely programmable
- High accuracy
- Compact design
- Zero-maintenance, lubricated for life

CAMCO



Features, Markets and Applications

 STRENGTH	<ul style="list-style-type: none"> • Large payload capacity in compact housing • High power to weight ratio 	 TRANSPORTATION	 MOLDING
 PERFORMANCE	<ul style="list-style-type: none"> • Lubricated for life for minimal wear • Industry standard alternative mounting options 	 CONSUMER	 CLEAN ROOM
 PRECISION	<ul style="list-style-type: none"> • Zero backlash with direct motor coupling • Smooth operation using a precision engineered roller cam and designs 	 PACKAGING	 FIXTURE/TESTING

PGM/GTB SERIES

Camco Servo Positioning Solutions | Options



Camco Servo Positioners

	Drive Mechanism		Type	
	P	Parallel Cam For light duty and low cost positioning	GM	Gear Head for Motors
	G	Globoidal (Roller Gear) For mid sized and precision positioning	TB	Table Type Reducer

PGM Series Parallel Gear Servo Positioner



PGM40
Max Start/Stop Torque:
63.9 Nm [47.13 ft lbs]

Precision Servo Reducer with Pre-loaded Parallel Cam Structure

The PGM parallel cam mechanism with pre-loaded structure offers accurate and rigid indexing performance. It is designed for low input inertia and offers greater servo performance through a wide variety of motor options.

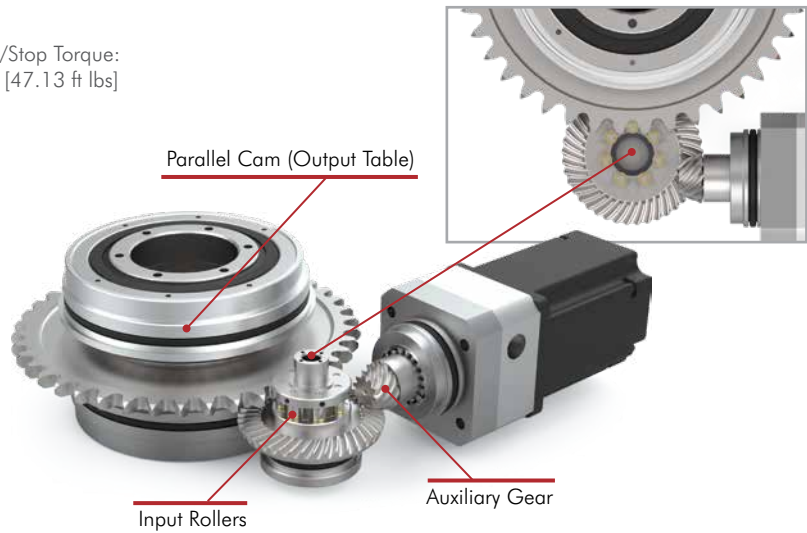

Thru-hole Design

Large opening through the center of the output flange is suitable for wiring and piping pass-thru.

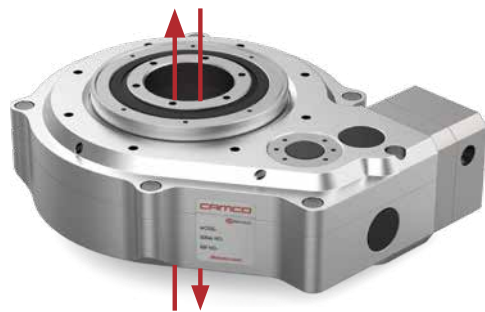

Integrated Motor Clamp System

The PGM offers a wide-variety of motor options that easily attach through the use of an integrated motor clamp.

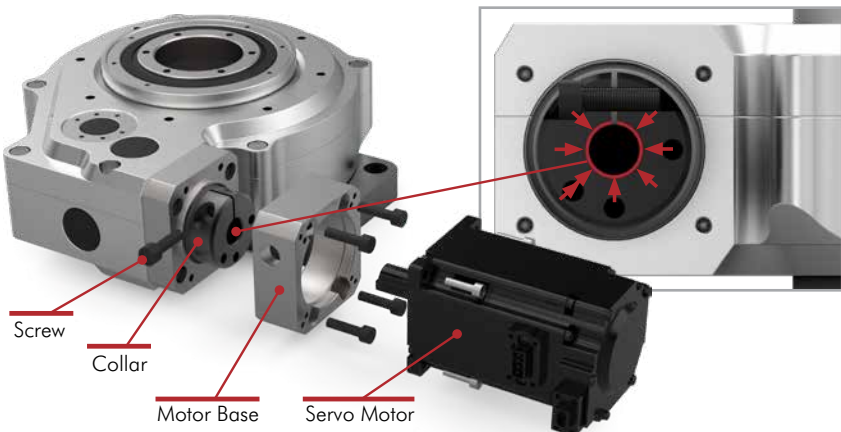



PGM/GTB SERIES

Camco Servo Positioning Solutions | Options

GTB Series Globoidal (Roller Gear) Servo Positioner



Zero Backlash Roller Gear Cam Mechanism

Innovative roller gear design provides exceptionally smooth motion performance. The globoidal cam and output turret with integrated rollers are a preloaded system that delivers zero backlash for superior accuracy, stiffness and long term durability.

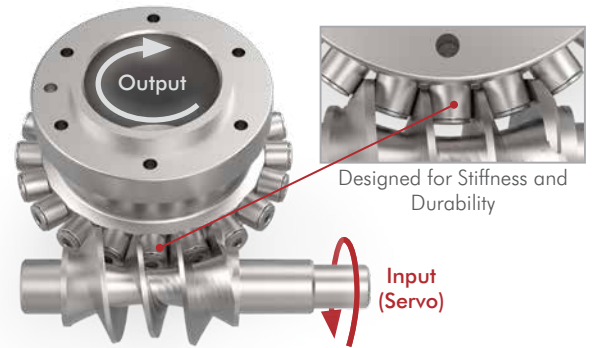

Flexible Drive Options

Each GTB model can be ordered in two different drive options.

The high-torque gear drive option is used for applications with large inertia requirements while maintaining a small motor size.

The direct drive option provides zero backlash, high precision operation. Both options interface with an array of servo motor suppliers.

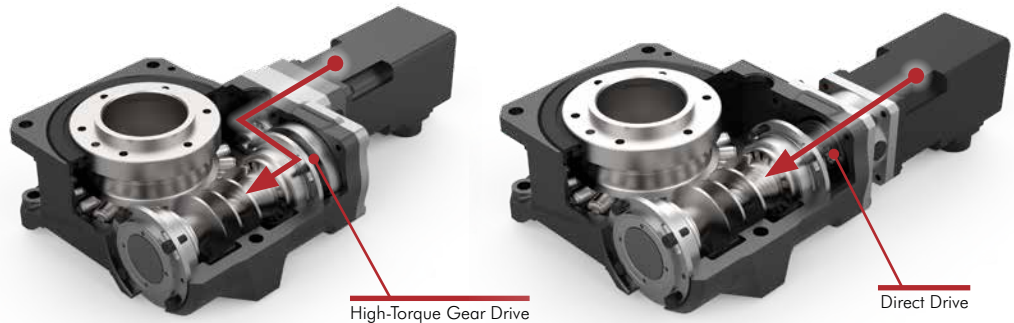

Competitive thru-hole and size comparison

The GTB Series feature the largest utility through hole diameter available for its size, making it ideal for space constrained machine applications.

The GTB is **34%** lower in height and **64%** lower in weight when compared to competitive models, while being able to deliver **1.4 times** more torque.



PGM Series Example Applications



Filling Head Positioner

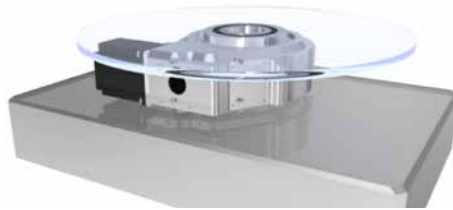

Rotary Positioner

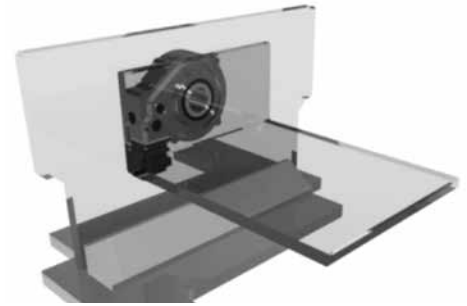

Tilting Positioner

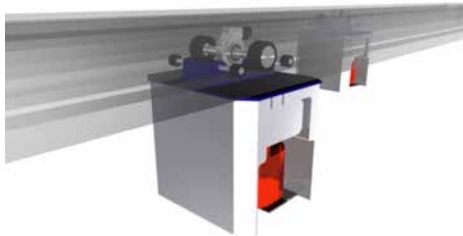

Automatic Guided Vehicle



Tool Changer Indexer



Inspection Table Drive

GTB Series Example Applications



Glass Grinder Indexer

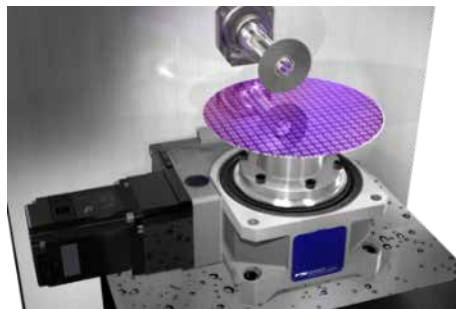

Si Wafer Dicing

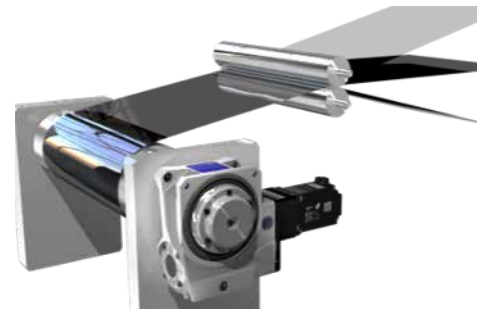

Film Roll Rotator



Filling Nozzle Oscillation

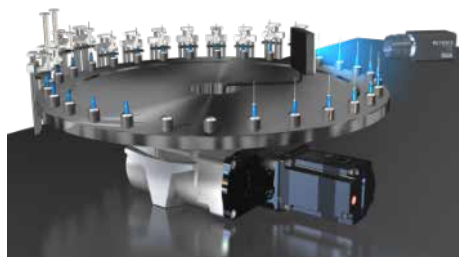

Inspection Indexer



Continuous Inspection Oscillator

Dimensions and technical information are subject to change without notice.

GERMANY
+49-6171-705-0
europe@destaco.com

UNITED KINGDOM
+44-1902-797980
uk@destaco.com

NETHERLANDS
+31-297285332
benelux@destaco.com

THAILAND
+66-2-326-0812
asia@destaco.com

USA
+1-888-DESTACO
+1-248-836-6700
northamerica@destaco.com

FRANCE
Tel: +33-4-7354-5001
france@destaco.com

SPAIN
+34-936361680
spain@destaco.com

CHINA
+86-21-6081-2888
china@destaco.com

INDIA
+91-80-41123421-426
india@destaco.com