

# 84A5-1 SERIES

## Cam Type Sheet Metal Grippers | Ordering Information

84A5 - 11 D5 A AA PA

### Fixed Lower Jaw Opening Options

**Description**

- 76° Jaw Opening (Standard)
- X 30° Jaw Opening
- Y 45° Jaw Opening
- Z 60° Jaw Opening

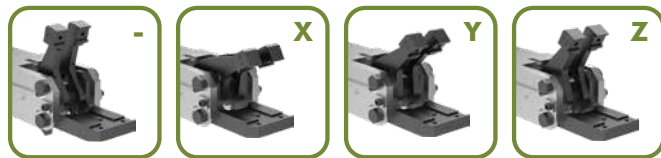

### Jaw Arrangement Options

**Description**

- 11 Double Upper, Single Lower, Straight Design
- 13 Double Upper and Lower, Straight Design

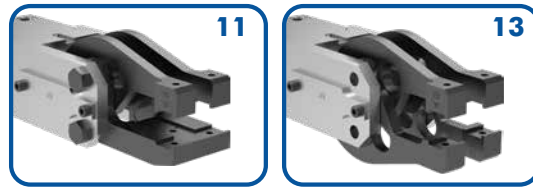

### Moveable Lower Jaw Opening Options

**Description**

- 76° Jaw Opening (Symmetrical)
- X 30° Jaw Opening (Symmetrical)
- Y 45° Jaw Opening (Symmetrical)
- Z 60° Jaw Opening (Symmetrical)
- R 76° Upper/15° Lower Jaw
- S 30° Upper/15° Lower Jaw
- T 45° Upper/15° Lower Jaw
- U 60° Upper/15° Lower Jaw

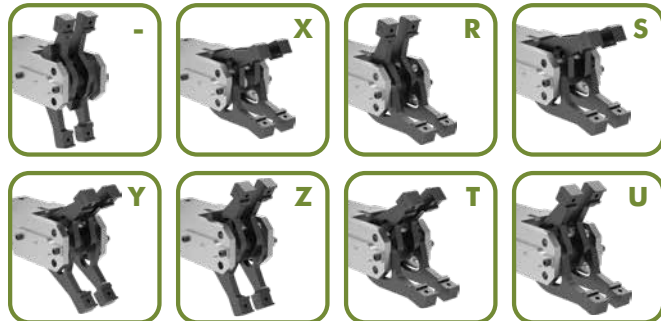

Specifications	Unit	
Piston	mm	50
Actuation Time (open/close)	sec	0.6
Air Consumption per Double Stroke at 5 bar	L	0.66

### Gripper Teeth and Points Options (Upper and Lower)

#### Steel Teeth

- 00** None
- AA** 8JZ-014-3



#### Plastic Teeth

- 00** None
- KA** 8JZ-021-1\*

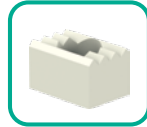

\*Cannot be used with **A8** sensor option.

#### Steel Points (Upper only)

- 00** None
- PA** 8MJ-1001-1
- PB** 8MJ-1002-1
- PC** 8MJ-1003-1



Shims for gripper teeth available  
Order Separately **8SB-003-1**  
Dimensions: 14,8 x 13 x 0,15 mm

### Sensor Options

- |           | Description  |
|-----------|--|
| <b>00</b> | None   |
| <b>A8</b> | Workpiece Control, Switching Distance 7mm<br>8EA-092-1 (for 84A5-11 only)* |
| <b>D5</b> | Double Sheet Control, M12x1 Plug - 8EA-087-1                               |
| <b>GK</b> | 2X <b>D5</b>   |
| <b>GN</b> | <b>A8</b> + <b>D5</b> (for 84A5-11 only)                                   |

\*Cannot be used with **KA** plastic teeth option.

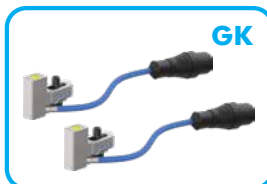
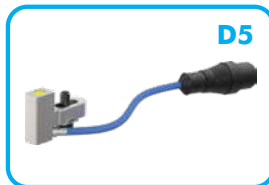

Shims for Sensor A8 available  
Order Separately **8MB-003-1**

### Mounting Options

- |          | Description             |
|----------|-------------------------|
| <b>0</b> | None                    |
| <b>A</b> | Rear Flange - 8MA-196-1 |



# 84A5.11 SERIES (SINGLE FIXED LOWER JAW)

Cam Type Sheet Metal Grippers | Dimensions and Technical Specifications

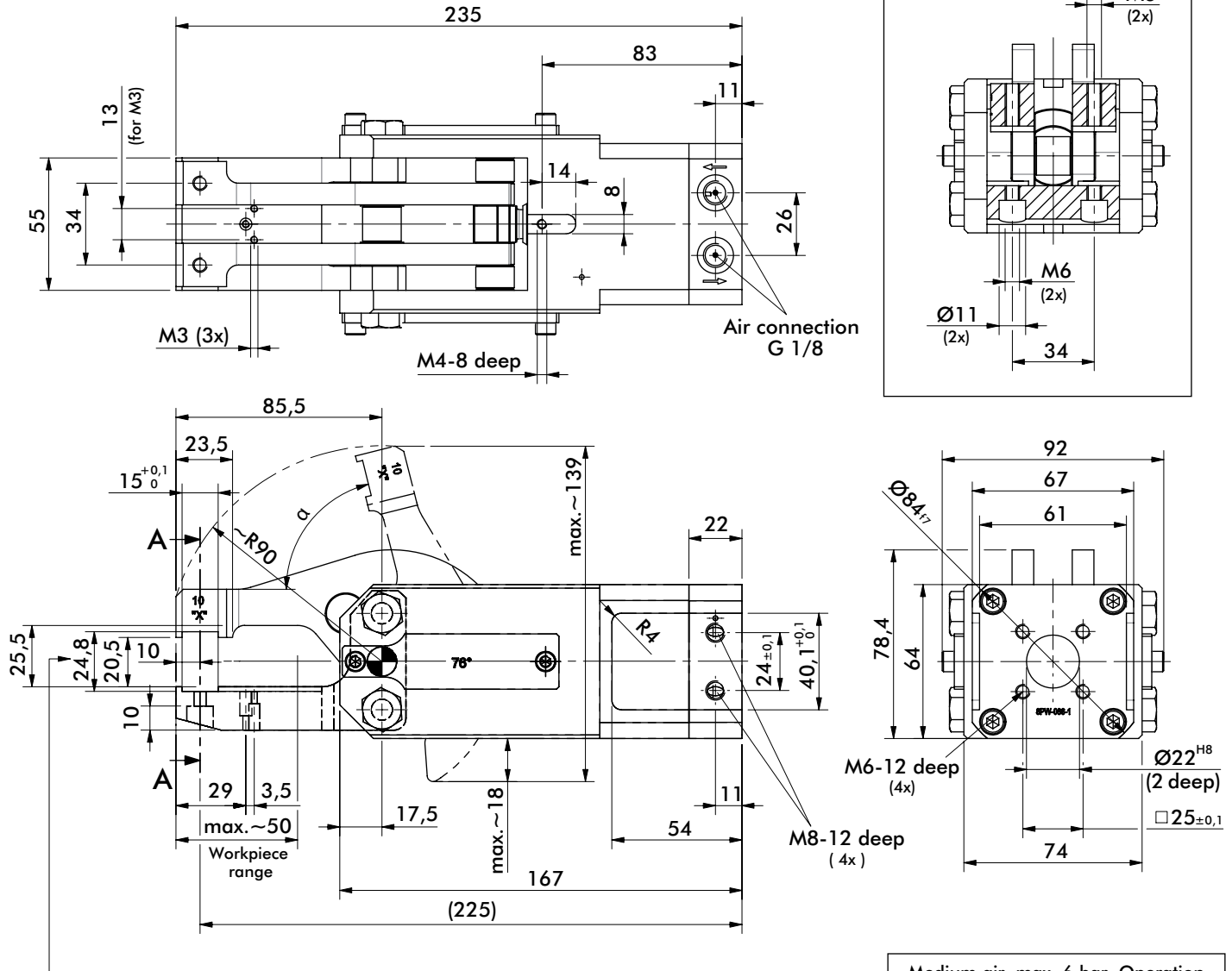

Addition of gripper teeth height and thickness of the clamped plate must be 24,8 mm. It might be necessary to use shim plates or to grind off the gripper teeth.

Medium air, max. 6 bar. Operation with oil-free air is permissible.

NOTE! Any extension of the moveable or fixed gripper jaws as well as the additional attachment of weights will void warrantee.

Model 84A5.11	Opening Angle $\alpha$	Clamping force at 5 bar ~N [lbs]	Weight Kg [lbs]
-	76°	2000 [450]	2,8 [6.17]
X	30°		
Y	45°		
Z	60°		

# 84A5.13 SERIES (DOUBLE SYMMETRICAL JAW)

## Cam Type Sheet Metal Grippers | Dimensions and Technical Specifications

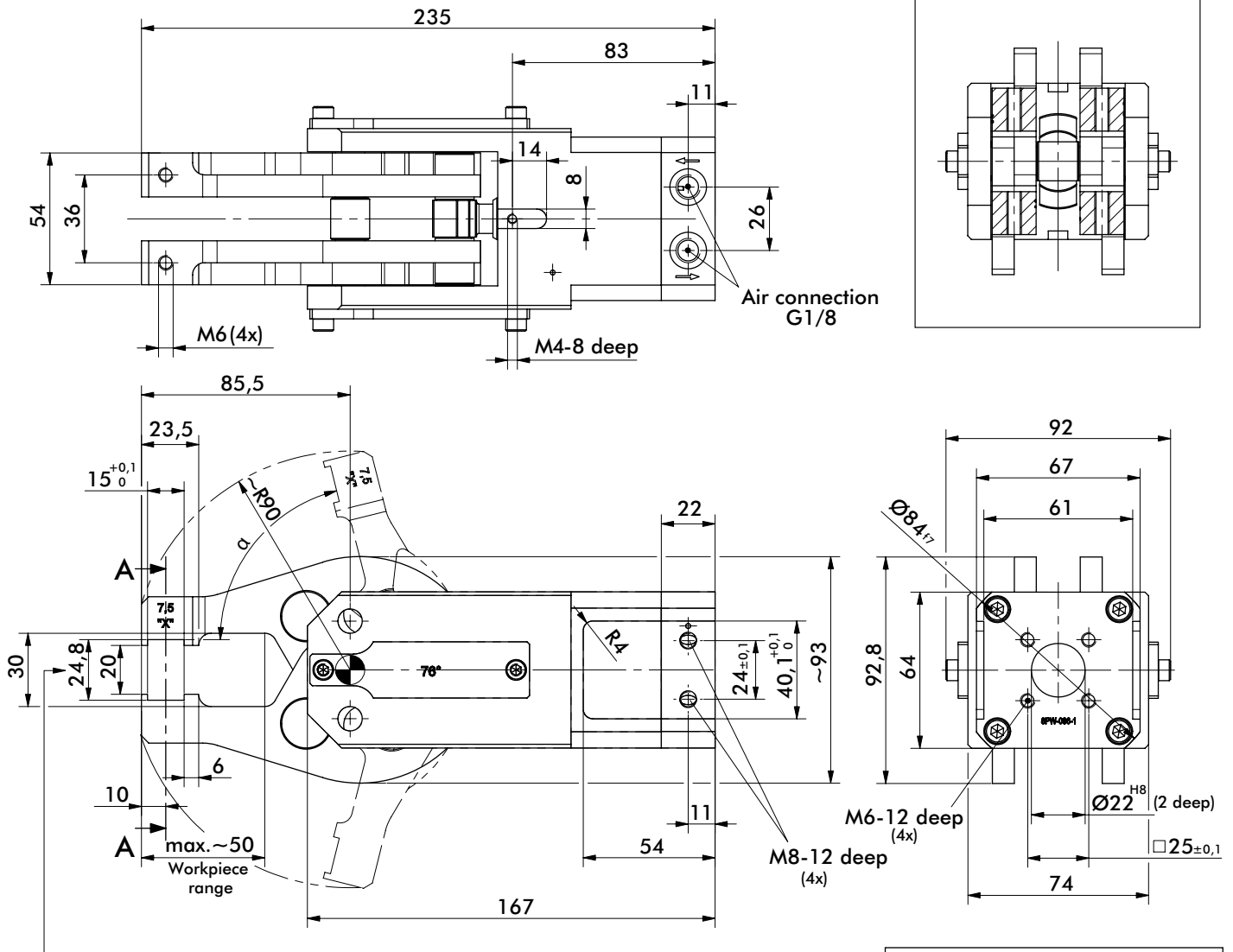
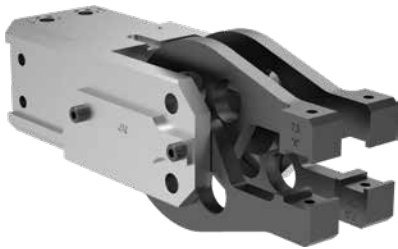

Addition of gripper teeth height and thickness of the clamped plate must be 24,8 mm. It might be necessary to use shim plates or to grind off the gripper teeth.

Medium air, max. 6 bar. Operation with oil-free air is permissible.

NOTE! Any extension of the moveable or fixed gripper jaws as well as the additional attachment of weights will void warrantee.

Model 84A5.13	Opening Angle $\alpha$ Symmetrical	Clamping force at 5 bar ~N [lbs]	Weight Kg [lbs]
-	76°	1200 [270]	2,8 [6.17]
X	30°		
Y	45°		
Z	60°		

# 84A5.13 SERIES (DOUBLE 15° LOWER JAW)

Cam Type Sheet Metal Grippers | Dimensions and Technical Specifications

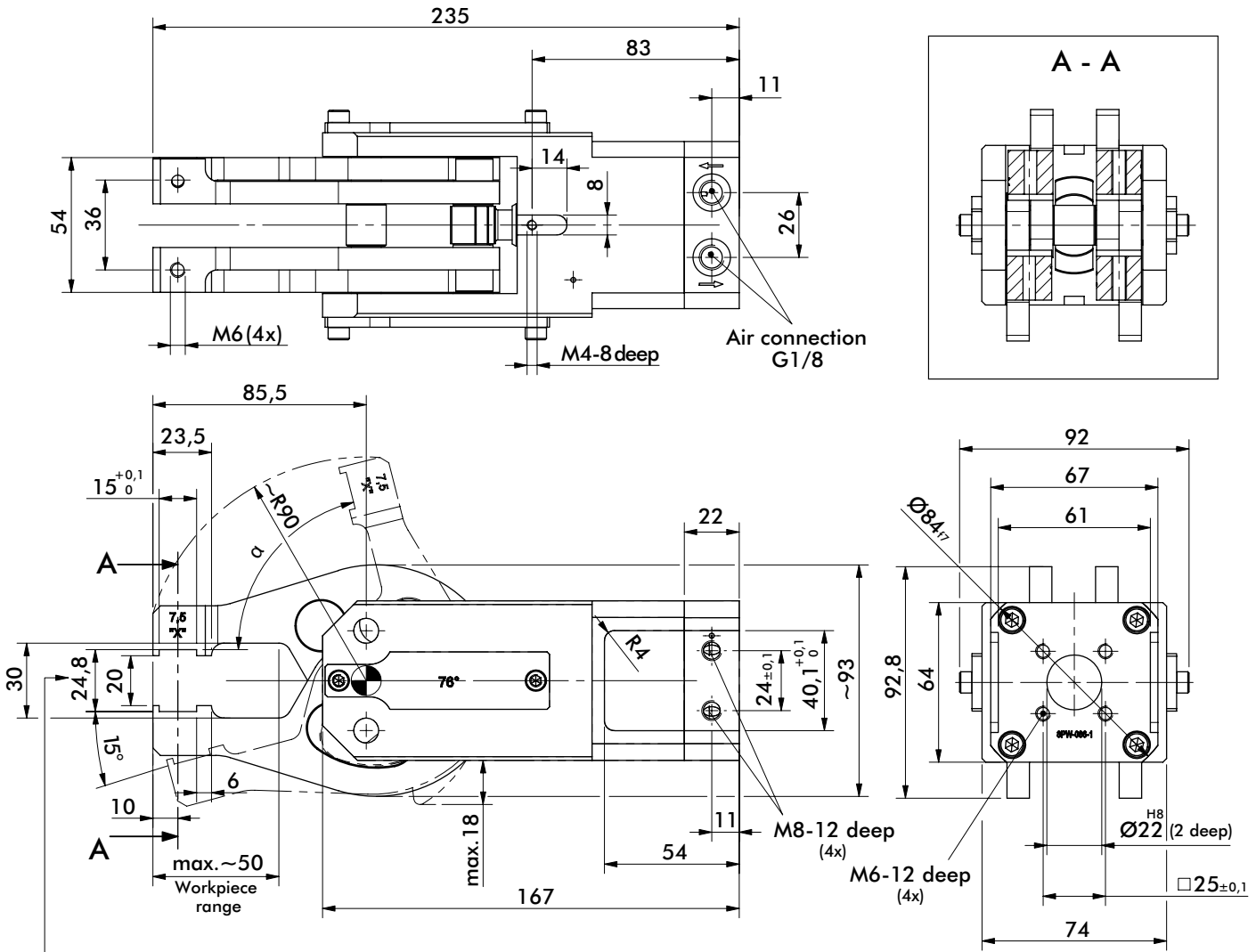

Addition of gripper teeth height and thickness of the clamped plate must be 24,8 mm. It might be necessary to use shim plates or to grind off the gripper teeth.

Medium air, max. 6 bar. Operation with oil-free air is permissible.

NOTE! Any extension of the moveable or fixed gripper jaws as well as the additional attachment of weights will void warrantee.

Model 84A5.13	Opening Angle $\alpha$ Upper/Lower	Clamping force at 5 bar ~N [lbs]	Weight Kg [lbs]
R	76°/15°	1200 [270]	2,8 [6.17]
S	30°/15°		
T	45°/15°		
U	60°/15°		

# 84A5-1 SERIES ACCESSORIES

## Cam Type Sheet Metal Grippers | Dimensions and Ordering Information

### Mount

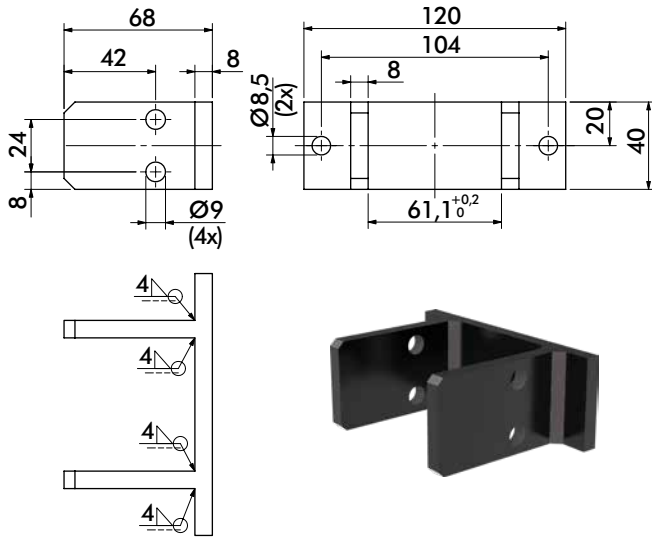

#### Mount

Rear Flange

#### Part Number

**8MA-196-1**

### Steel Teeth

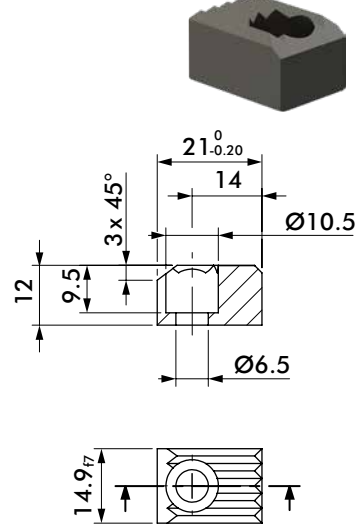

#### Steel Teeth

Serrated

#### Part Number

**8JZ-014-3**

### Plastic Teeth

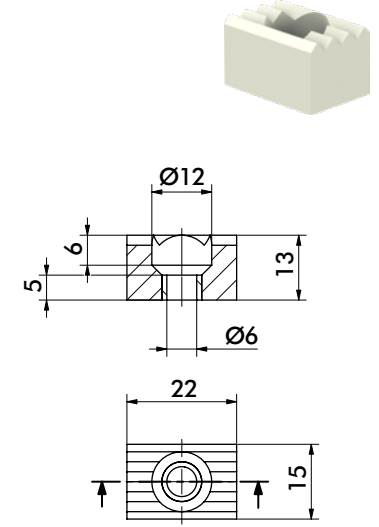

#### Plastic Teeth

Serrated

#### Part Number

**8JZ-021-1**

### Steel Points

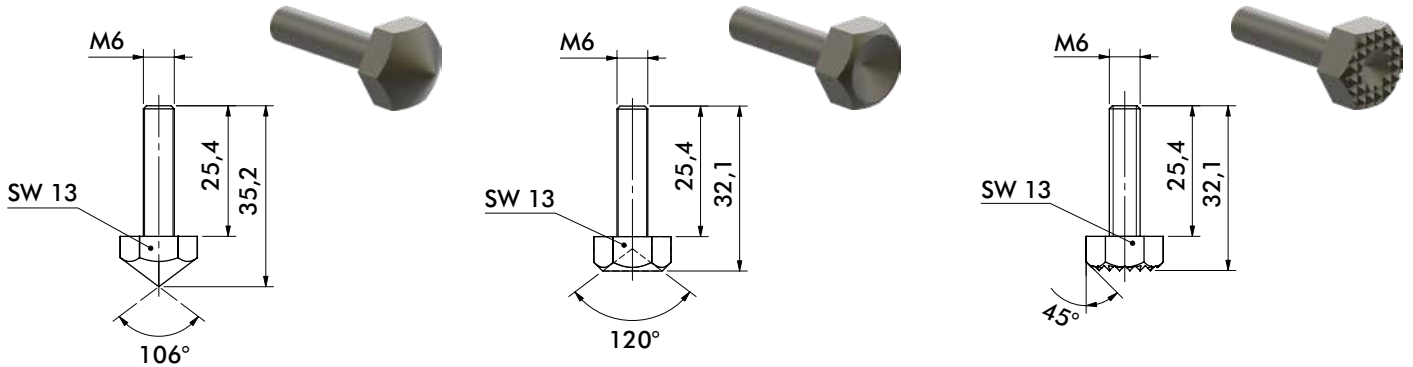

#### Steel Point

Pointed

#### Part Number

**8MJ-1001-1**

#### Steel Point

Flat

#### Part Number

**8MJ-1002-1**

#### Steel Point

Serrated

#### Part Number

**8MJ-1003-1**

### Sensors

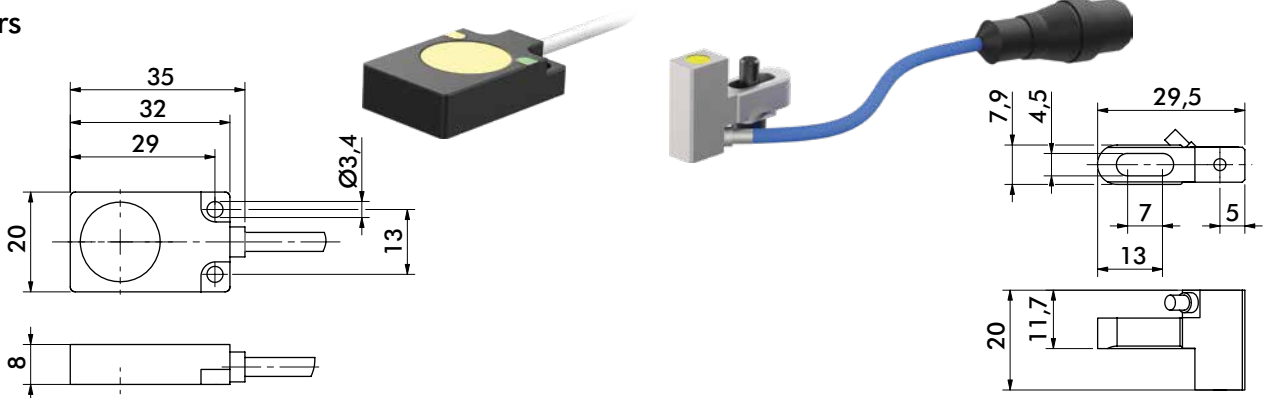

#### Workpiece Control Sensor

7mm Sensing Distance, 2m Cable

#### Part Number

**8EA-092-1**

#### Double Sheet Control Sensor

1.5mm Sensing Distance

#### Part Number

**8EA-087-1**