

PRECISION INDEXING SOLUTIONS

Table of Contents

INDEXERS

Servo Positioners



GTB Series
Globoidal (Roller Gear)
Servo Positioner.....IN-SRV-1



RSD Series
Rotary Servo Drives.....IN-SRV-39

Mechanical Indexers



RDM Series
Rotary Index Drive IN-MCH-2



RD Series
Roller Dial Index Drive..... IN-MCH-18



E Series
Heavy-Duty Index Drive IN-MCH-30



RA Series
Right Angle Index Drive IN-MCH-42



RGD/RGS Series
Roller Gear Index Drive IN-MCH-52



P Series
Parallel Shaft/Flange Drive.... IN-MCH-72



RNG Series
Ring Drive Dial Indexer.....IN-MCH-84

OVERLOAD CLUTCHES



Overload Clutches
Output Overload..... IN-CLU-1

CUSTOM CAMS



Custom Cams
Cam Design Solutions IN-CAM-1

CONVEYORS



Rite-Link Series
Thin-Profile.....IN-CNV-1



Precision Link Series
Table-TopIN-CNV-4



Precision Link Series
Heavy-Duty IN-CNV-16

PARTS HANDLERS



LPP Series
Linear Part Handlers IN-PRT-2



RPP Series
Rotary Part Handlers IN-PRT-8

RIGHT ANGLE INDEX DRIVES

Features | Table of Contents



Features:

CAMCO Right Angle Index Drives are ideal for dial applications or actuation-type applications such as driving a linkage or in-line conveyor.

Fixed center distance between input and output

Hardened, ground barrel cam

Compact design requiring minimum use of floor space.

Preloaded “rib-centered” design with modified-sine motion provides smooth acceleration and deceleration with precision positioning.

Universal mounting available on RA models.

Table of Contents

How to Order	3
400RA	5
512RA	7
662RA	9

RA SERIES

Right Angle Index Drive | How to Order

Indexer Ordering Procedure

1. Model
2. Input Shaft Configuration
 - Side 1
 - Side 2
 - Double Input – DI (Standard)
4. Indexer Mounting Position: 1-6
5. Indexer Housing Mounting Holes: Side 1-6 (more than one side can be selected)

Reducer Ordering Procedure

1. Model
2. Ratio: 5:1, 10:1, 15:1, 20:1, 25:1, 30:1, 40:1, 50:1, 60:1
3. Motor Adapter
4. Reducer Input Shaft Extension: Single Input (SE) or Double Input (DE)
5. Mounting (see diagram below)

Input Shaft Configuration (Top View)

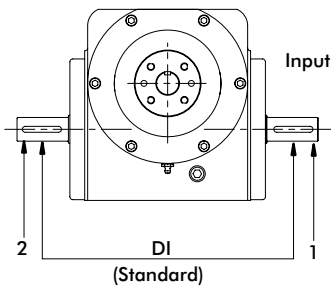

Input Shaft Rotation

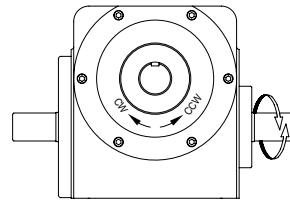

Relative Rotation for Right Hand Cam:

- CW Input Side 1 CCW Output
- CCW Input Side 2 CCW Output

NOTE: Input can be driven in either direction

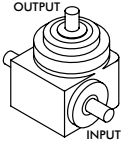
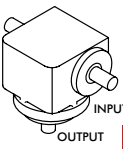
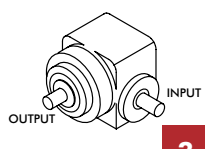
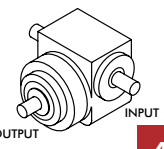
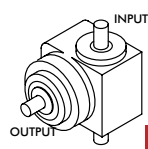
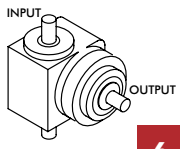
OVOI (output vertical, over input)	OVUI (output vertical, under input)	OHOI (output horizontal, over input)	OHUI (output horizontal, under input)	H-S1-UP (output horizontal, side 1 up)	H-S2-UP (output horizontal, side 2 up)
 1	 2	 3	 4	 5	 6

Gear Reducer Mounting Positions

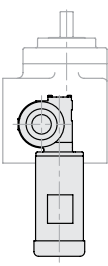
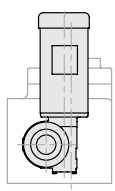
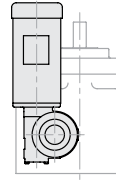
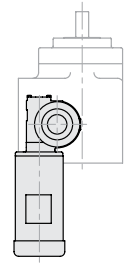
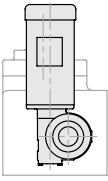
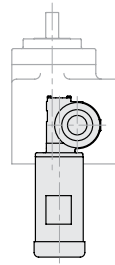
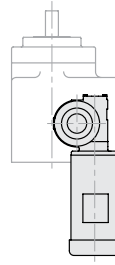
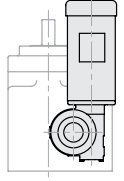
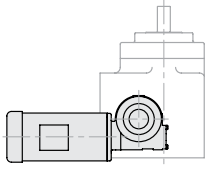
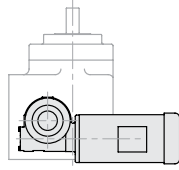
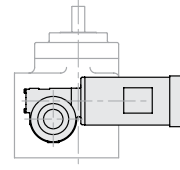
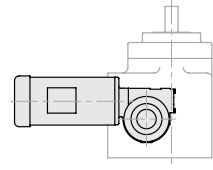
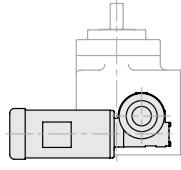
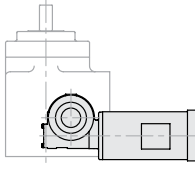
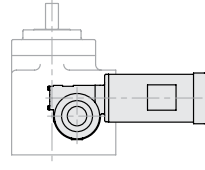
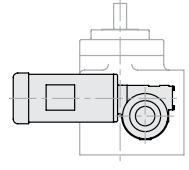
		Mounting "A"		Mounting "B"	
		RH	LH	RH	LH
SIDE 1	 A	 B	 C	 D	
	SIDE 2	 E	 F	 G	 H
		Mounting "C"		Mounting "D"	
		RH	LH	RH	LH
SIDE 1	 J	 K	 L	 M	
	SIDE 2	 N	 P	 R	 S

400RA SERIES

Right Angle Index Drive | Dimensions

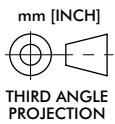
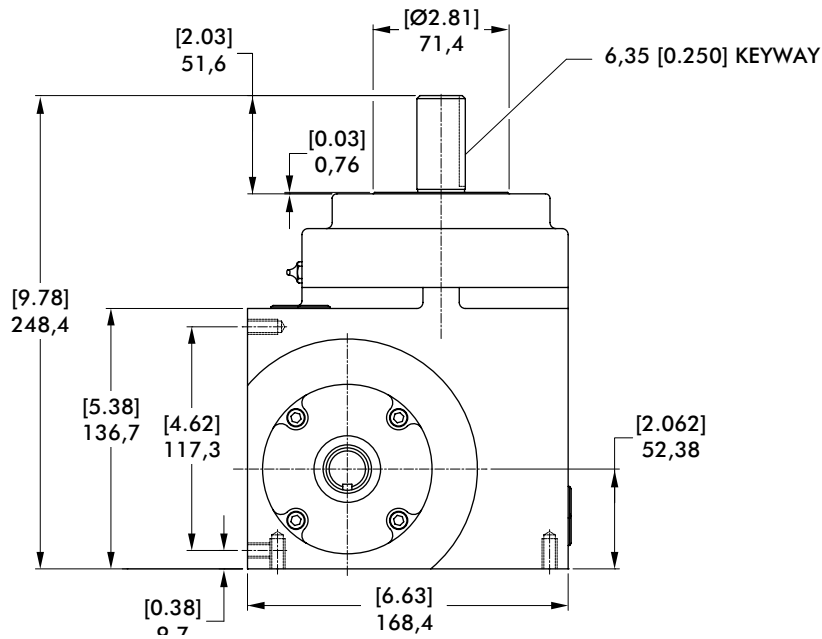
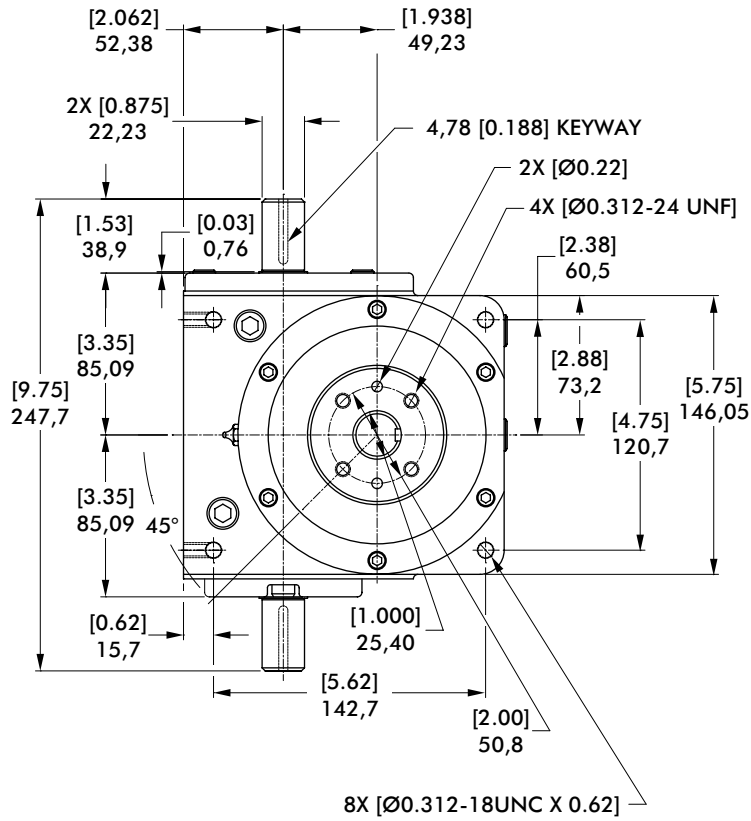

400RA Indexer Capacities					
Stops	Index Period	Motion	B ₁₀ Capacity at 50 RPM N-m [in-lb]	Internal Inertia kg-cm ² [lb-in ²]	Model
2	330	ms	67 [595]	44 [15]	400RA2H20-330
3	270	ms	180 [1591]	44 [15]	400RA3H24-270
4	270	ms	210 [1858]	44 [15]	400RA4H24-270
	180	ms	237 [2098]	44 [15]	400RA4H24-180
6	270	ms	193 [1711]	44 [15]	400RA6H24-270
	120	ms	229 [2024]	44 [15]	400RA6H24-120
8	270	ms	224 [1987]	44 [15]	400RA8H24-270
	120	ms	266 [2354]	44 [15]	400RA8H24-120
12	270	ms	146 [1290]	44 [15]	400RA12H20-270
	120	ms	177 [1568]	44 [15]	400RA12H20-120
16	270	ms	161 [1426]	44 [15]	400RA16H20-270 II
	180	ms	333 [2947]	44 [15]	400RA16H24-180 II
24	270	ms	185 [1640]	44 [15]	400RA24H20-270 II
	180	ms	214 [1894]	44 [15]	400RA24H20-180 II

Other Motions (stops and index periods) available. Contact your DESTACO sales representative for more information.

Features

- R180 Reducer (ratios from 15:1 to 60:1)
 - Double Extended Worm Shaft (Input)
 - Worm Shaft Handwheel
- Double Extended Camshaft (Input Shaft)
- 1/3 HP AC Drive Package with Inverter Duty Motor and IM-pAC AC Drive (up to 60 cpm)
- Cycle Cam and Limit Switch Mounted to Camshaft
- Right Hand Cam

Output Load Capacity (loads carried during index):

Radial	3603 N [810 lbs]
Thrust/Axial	6254 N [1406 lbs]
Moment	183 N-m [1620 in-lb]

Accuracy

±48 arcsec / ±0,178 mm [±.0007 in]
at 76,2 [3 in] Radius

Repeatability

±12 arcsec / ± 0,051 mm [±.0002 in]
at 76,2 [3 in] Radius

Optional Accessories

- 1/3 hp DC motor
- R225 Reducer (ratios from 10:1 to 60:1)
 - 1 hp DC Motor
 - 56C Motor Adapter and Coupling
- Varipak DC Motor Control (up to 30 cpm)
- Output Overload Clutch Models: 2.3F, 2.3FC, 2.3S, 2.3C, 2.3FC-SD, 2.3S-SD, 2.3C-SD
 - Available Settings (in-lb): 400, 600, 700, 850, 1000, 1300, 1800, 2000, 2300
- Dual Cycle Cam and Limit Switch
- Finished cover for ceiling mount or tooling plate mounting
- Left Hand Cam
- Relief in Dwell for shot-pin applications

512RA SERIES

Right Angle Index Drive | Dimensions

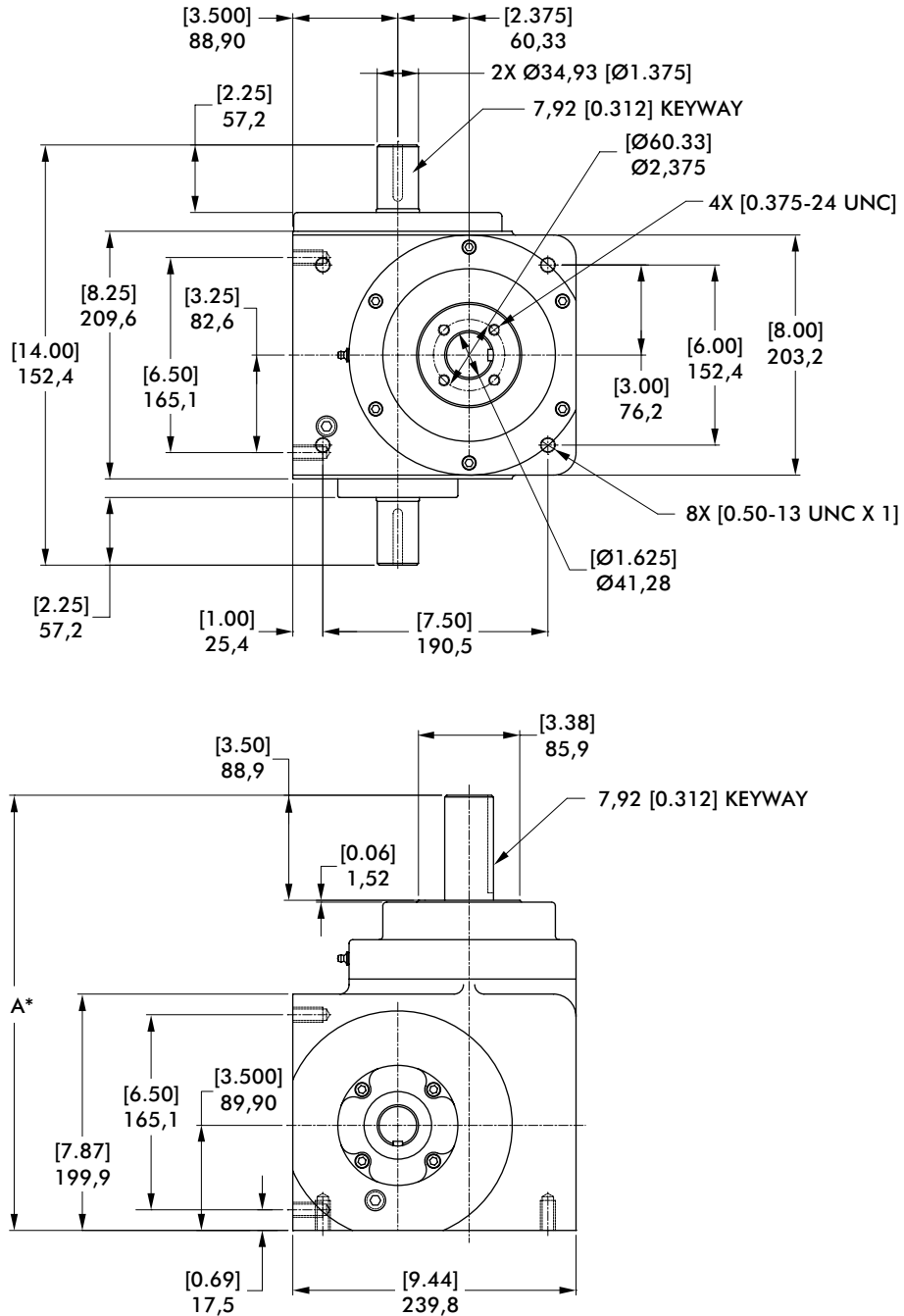

*See table on top of page 8 for dimensions

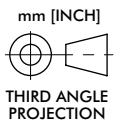

512RA Indexer Capacities						
Stops	Index Period	Motion	B ₁₀ Capacity at 50 RPM N-m [in-lb]	Internal Inertia kg-cm ² [lb-in ²]	Model	A
2	270	msc.33	233 [2061]	132 [45]	512RA2H32-270 MSC.33	379,2 [14.93]
3	270	ms	267 [2360]	132 [45]	512RA3H32-270	368,3 [14.50]
	180	msc.33	322 [2852]	132 [45]	512RA3H32-180 MSC 0.33	379,2 [14.93]
4	270	ms	306 [2710]	132 [45]	512RA4H32-270	368,3 [14.50]
	120	msc.33	412 [3648]	132 [45]	512RA4H32-120 MSC 0.33	379,2 [14.93]
6	270	ms	295 [2613]	132 [45]	512RA6H32-270	368,3 [14.50]
	120	ms	359 [3179]	132 [45]	512RA6H32-120	368,3 [14.50]
8	270	ms	358 [3172]	132 [45]	512RA8H32-270	368,3 [14.50]
	120	ms	430 [3802]	132 [45]	512RA8H32-120	368,3 [14.50]
12	270	ms	309 [2738]	132 [45]	512RA12H28-270	368,3 [14.50]
	120	ms	359 [3176]	132 [45]	512RA12H28-120	379,2 [14.93]

Other Motions (stops and index periods) available. Contact your DESTACO sales representative for more information.

Features

- R225 Reducer (ratios from 10:1 to 60:1)
– 56C Motor Adapter and Coupling
- Double Extended Camshaft (Input Shaft)
- 1 HP AC Drive Package with Inverter Duty Motor and Inverter Drive (up to 60 cpm)
- Cycle Cam and Limit Switch Mounted to Camshaft
- Right Hand Cam

Output Load Capacity (loads carried during index):

Radial	8834 N [1,986 lbs]
Thrust/Axial	10129 N [2,277 lbs]
Moment	785 N-m [6,951 in-lb]

Accuracy

±37 arcsec / ±0,028 mm [±.0011 in]
at 152,4 [6 in] Radius

Repeatability

±9 arcsec / ± 0,008 mm [±.0003 in]
at 152,4 [6 in] Radius

Optional Accessories

- 1 hp DC motor
- Varipak DC Motor Control (up to 30 cpm)
- Output Overload Clutch Models: 6.0F, 6.0FC, 6.0S and 6.0C, 6.0C-SD, 6.0FC-SD, 6.0S-SD
– Available Settings (in-lb): 670, 825, 1100, 1400, 1700, 2000, 2300, 2500, 3000, 3800, 4000, 5000, 6000
- Dual Cycle Cam and Limit Switch
- Finished cover for ceiling mount or tooling plate mounting
- Left Hand Cam
- Relief in Dwell for shot-pin applications

662RA SERIES

Right Angle Index Drive | Dimensions

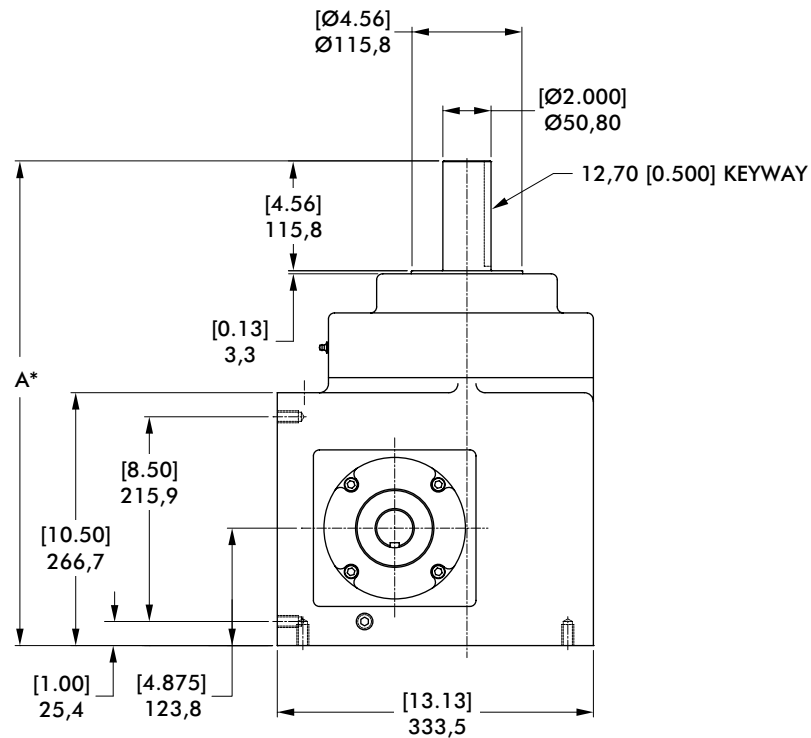
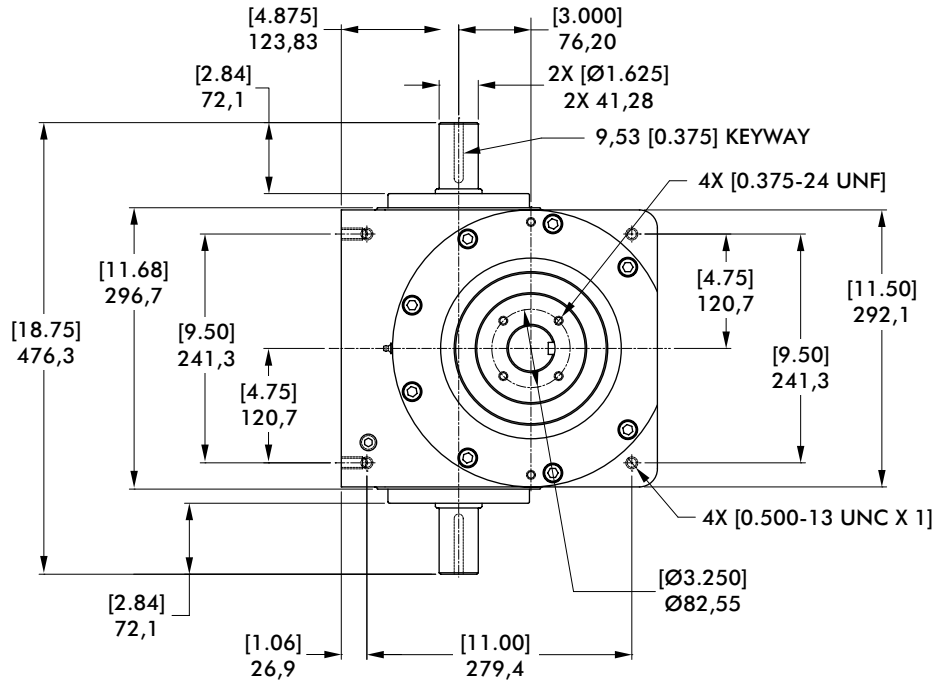

*See table on top of page 8 for dimensions

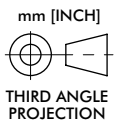

512RA Indexer Capacities						
Stops	Index Period	Motion	B ₀ Capacity at 50 RPM N-m [in-lb]	Internal Inertia kg-cm ² [lb-in ²]	Model	A
2	270	msc.33	738 [6534]	503 [172]	512RA2H32-270 MSC.33	379,2 [14.93]
3	270	ms	668 [5913]	495 [169]	512RA3H32-270	368,3 [14.50]
	180	msc.33	694 [6146]	495 [169]	512RA3H32-180 MSC 0.33	379,2 [14.93]
4	270	ms	780 [6903]	503 [172]	512RA4H32-270	368,3 [14.50]
	120	msc.33	876 [7751]	503 [172]	512RA4H32-120 MSC 0.33	379,2 [14.93]
6	270	ms	648 [5734]	495 [169]	512RA6H32-270	368,3 [14.50]
	120	ms	853 [7551]	495 [169]	512RA6H32-120	368,3 [14.50]
8	270	ms	812 [7187]	503 [172]	512RA8H32-270	368,3 [14.50]
	120	ms	1015 [8987]	503 [172]	512RA8H32-120	368,3 [14.50]
12	270	ms	509 [4504]	483 [165]	512RA12H28-270	368,3 [14.50]
	120	ms	625 [5536]	483 [165]	512RA12H28-120	379,2 [14.93]

Other Motions (stops and index periods) available. Contact your DESTACO sales representative for more information.

Features

- 7300C Reducer (ratios from 5:1 to 60:1)
 - Motor Adapter and Coupling
- Double Extended Camshaft (Input Shaft)
- 1 or 2 HP AC Drive Package with Inverter Duty Motor and Inverter Drive (up to 60 cpm)
- Varipak DC Motor Control (up to 30 cpm)
- Cycle Cam and Limit Switch Mounted to Camshaft
- Right Hand Cam

Output Load Capacity (loads carried during index):

Radial	12642 N [2842 lbs]
Thrust/Axial	23304 N [5239 lbs]
Moment	334 N-m [2959 in-lb]

Accuracy

±36 arcsec / ±0,025 mm [±.001 in]
at 152,4 [6 in] Radius

Repeatability

±9 arcsec / ± 0,008 mm [±.0003 in]
at 152,4 [6 in] Radius

Optional Accessories

- 1 hp DC motor
- 7350C Reducer (ratios from 5:1 to 60:1)
 - Motor Adapter and Coupling
- 2 hp DC Motor with Varipak DC Motor Control (up to 30 cpm)
- Output Overload Clutch Models: 11F, 11FC, 11FC-SD
 - Available Settings (in-lb): 2300, 4000, 6000, 8500, 11,000
- Dual Cycle Cam and Limit Switch
- Finished cover for ceiling mount or tooling plate mounting
- Left Hand Cam
- Relief in Dwell for shot-pin applications