

# 817, 827 SERIES

## Pneumatic Toggle Clamps | Product Overview

### Features:

- Dual mounting surfaces for maximum flexibility
- Sensor ready for round or T-slot style sensors
- Built-in flow restriction eliminates need for external flow controls

### Applications:

- Assembly
- Welding

### Also Available:

See page MC-ACC-1 for spindle accessories  
See page MC-PSC-38 for sensing options

817-U  
817-UE



817-S  
817-SE



827-U  
827-UE



827-S  
827-SE



## Technical Information | Holding Capacities

Model	Maximum Holding Capacity		Max. Exerting Force @ 5bar [72PSI]		Weight	Bore Size	Air Consumption† dm³ [ft³]	Port Size	Accessories (Supplied)		
	Inner	Outer	Inner	Outer					Spindle Accessory	Flanged Washers	Bolt Retainer
817-U	[375 lbf] 1670 N		[369 lbf] 1648 N					1/8NPT	--	507107	--
817-UE		[200 lbf] 890 N		[225 lbf] 1005 N	1,05kg [2.31lb]	[1.26] 32	[0.015] 0,42	G-1/8	225208-M		
817-S	[450 lbf] 2000 N		[360 lbf] 1608 N					1/8 NPT	--	--	207107
817-SE								G-1/8			
827-U	[600 lbf] 2670 N	[390 lbf] 1735 N		[309 lbf] 1383 N				1/8 NPT	--	235106	--
827-UE			[491 lbf] 2200 N		2,14kg [4.71lb]	[1.57] 40	[0.029] 0,83	G-1/8	240208-M		
827-S	[700 lbf] 3110 N	[330 lbf] 1470 N		[281 lbf] 1257 N				1/8 NPT	--	--	210114
827-SE								G-1/8			

†Per double stroke at 5bar [72PSI]

**Max Cylinder Pressure:** 10bar [145psig]\*

**Max Operating Temp:** -10°C to 90°C [-14°F to 194°F]

**Replacement Seal Kit:** 817: 802450-32-1-00  
827: 810450-40-1-00

**Replacement Clamp Assembly:** 817-U-LC, 817-S-LC, 827-U-LC, 827-S-LC

**Replacement Cylinder Assembly:** 817: 807CYL, 827: 810CYL

\*In no case should the inlet pressure be high enough to create an exerting force that exceeds the clamp's holding capacity. See Technical Appendix Section for details.

### Sensor Accessories

	Item Number
Round Reed Switch with Quick Disconnect	810169
T-slot Reed Switch with Quick Disconnect	8EA-109-1
Quick Disconnect 2M Extension Cable	CABL-010
Quick Disconnect 5M Extension Cable	CABL-013

See Pneumatic Accessories section for more options

# 817, 827 SERIES

Pneumatic Toggle Clamps | Dimensions | -U/-UE/-S/-SE

817-U  
817-UE



817-U / 817-S / 827-U / 827-S 1/8" NPT  
817-UE / 817-SE / 827-UE / 827-SE G-1/8

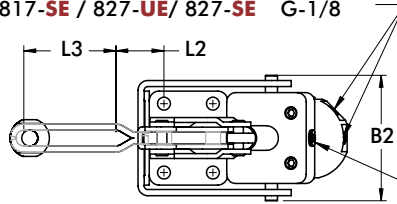

AUXILIARY UNCLAMP PORT  
(817-U, 817-S, 827-U, 827-S ONLY)

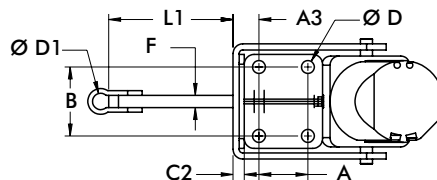
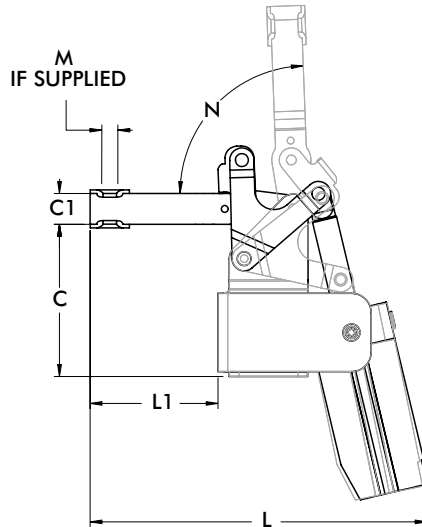
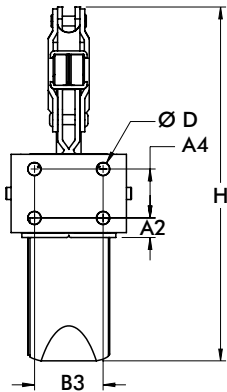

mm [INCH]  
THIRD ANGLE  
PROJECTION

### Mounting Options:

Use two bolts in the "side" mounting holes, to secure mounting bracket, when "top" mounting.

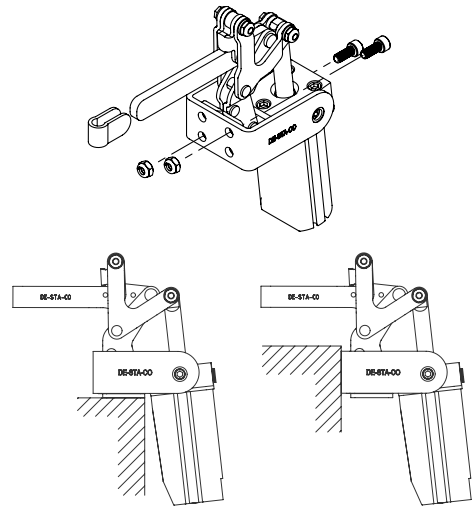

Top Mounting

Side Mounting

Model	A	A2	A3	A4	B	B2	B3	C	C1	C2	C3	C4
817-U												
817-UE	[0.63]	[0.44]	[0.60]	[0.63]	[1.00]	[2.44]	[1.00]	[2.69]	[0.63]	[0.12]	[1.25]	[1.31]
817-S	16	11,2	15,1	16	25,4	62	25,4	68,3	16	3,1	31,8	33,3
817-SE												
827-U								[3.89]	[0.79]			[1.76]
827-UE	[1.25]	[0.51]	[0.66]	[1.25]	[1.75]	[3.08]	[1.75]	98,8	20	[0.12]	[2.00]	44,8
827-S	31,8	12,8	16,8	31,8	44,45	78,3	44,45	[3.91]	[0.75]	3,1	50,8	[1.78]
827-SE								99,2	19,1			45,3

Model	ØD	ØD1	F	H	L	L1	L2	L3	M	N
817-U					[6.24]	[2.37]	[0.19]	[1.90]		
817-UE	[0.27]	-	-	[7.51]	158,6	60,3	4,8	48,4	5/16 M8	95°
817-S	6,7	[0.34]	[0.25]	190,7	[6.97]	[3.04]	-	-		
817-SE		8,7	6,4		175,5	77,2				
827-U					[8.61]	[3.27]	[1.23]	[2.35]		
827-UE	[0.33]	-	-	[9.04]	218,7	83,1	31,2	59,7	3/8 M10	88°
827-S	8,4	[0.42]	[0.31]	229,7	[8.49]	[3.18]	-	-		
827-SE		10,7	7,9		215,6	80,7				