

# 807 SERIES

## Pneumatic Toggle Clamps | Product Overview

### Features:

- Pneumatic version of Series 207 manual clamps
- Sensor ready for round or T-slot sensors.
- Built-in flow restriction eliminates need for external flow controls

### Applications:

- Assembly
- Welding

### Also Available:

See page MC-ACC-1 for spindle accessories

See page MC-PSC-38 for sensing options

High temperature version available upon request, add **-HT** to model number. Example: 807-U-**HT**

807-U  
807-UE



807-S  
807-SE



## Technical Information | Holding Capacities

Model	Maximum Holding Capacity		Maximum Exerting Force @ 5bar [72PSI]		Accessories (Supplied)						
	Inner	Outer	Inner	Outer	Weight	Bore Size	Air Consumption† dm <sup>3</sup> [ft <sup>3</sup> ]	Port Size	Spindle Accessory	Flanged Washers	Bolt Retainer
807-U	[375 lbf]	[275 lbf]	[576 lbf]	[297 lbf]	[1.66lb] 0,75kg	[1.26] 32	[0.015] 0,42	1/8 NPT	--	507107	--
807-UE	1670 N	1220 N	2573 N	1327 N				G-1/8	2007208-M		
807-S	[500 lbf]	[260 lbf]	[540 lbf]	[180 lbf]	0,75kg	32	0,42	1/8 NPT	--	--	207105
807-SE	2220 N	1160 N	2412 N	804 N				G-1/8			

†Per double stroke at 5bar [72PSI]

**Max Cylinder Pressure:** 10bar [145psig]\*

**Max Operating Temp:** -10°C to 90°C [-14°F to 194°F]

**Replacement Seal Kit:** 802450-32-1-00

**Replacement Clamp Assembly:** 807-U-LC, 807-S-LC

**Replacement Cylinder Assembly:** 807CYL

\*In no case should the inlet pressure be high enough to create an exerting force that exceeds the clamp's holding capacity. See Technical Appendix for details.

### Sensor Accessories

	Item Number
Round Reed Switch with Quick Disconnect	810169
T-slot Reed Switch with Quick Disconnect	8EA-109-1
Quick Disconnect 2M Extension Cable	CABL-010
Quick Disconnect 5M Extension Cable	CABL-013

See Pneumatic Accessories section for more options

# 807 SERIES

## Pneumatic Toggle Clamps | Dimensions

807-U  
807-UE

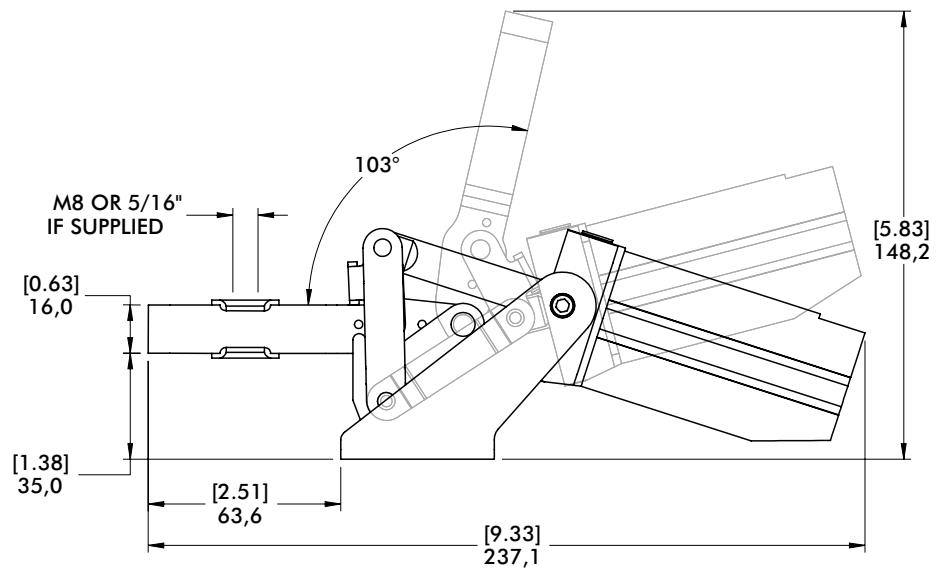
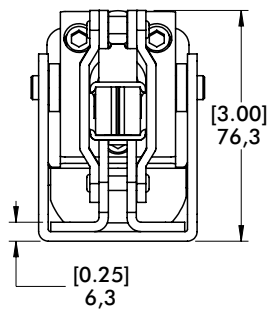
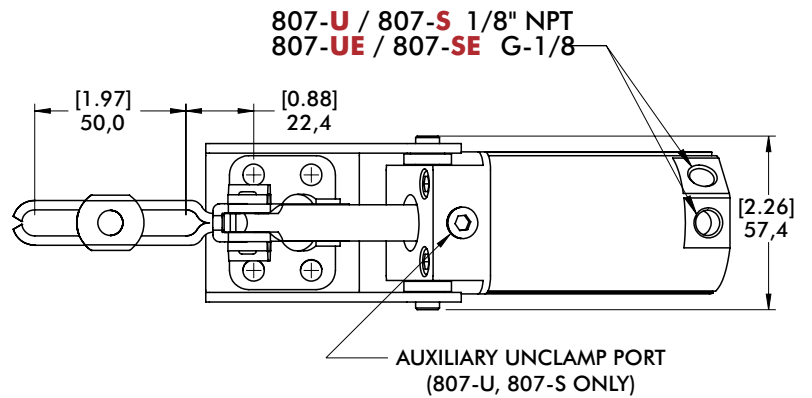

807-S  
807-SE

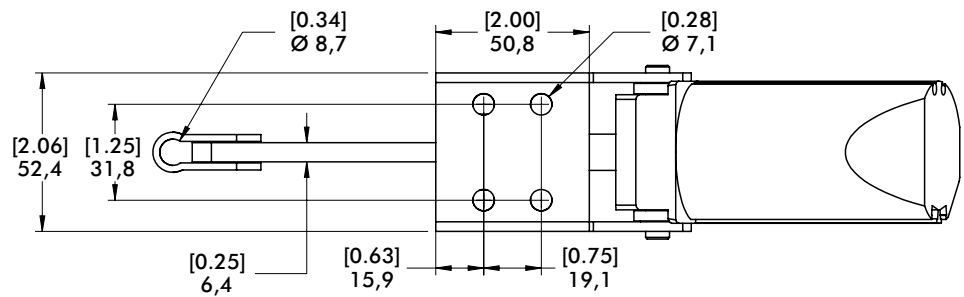

mm [INCH]  
THIRD ANGLE PROJECTION