

# 89E SERIES

## Pneumatic Swing Clamps | Product Overview

### Features:

- Lightweight and robust, designed for several millions cycles
- Threaded body may be mounted in a tapped hole or a clearance hole with optional mounting flange
- Metric design
- Clamp arm sold separately

### Applications:

- Assembly
- Welding
- Light machining

### Also Available:

See page MC-PSC-26 for clamping arms  
See page MC-PSC-27 for mounting flanges

### Series 89E



## Technical Information

Model	Swing Direction	Total Stroke [in]mm S	Stroke During Rotation [in]mm S1	Vertical Clamp Stroke [in]mm S2	Clamping Force [lbf.] N†	Bore Size mm[in]	Air Consumption‡ [ft³]dm³	Weight [lb.]kg	Replacement Seal Kit
89E20-010-2R	RH	[0.79]	[0.39]		[29]	[0.79]	[0.003]	[0.64]	89B/E20-2-00
89E20-010-2L	LH	20	10		130	20	0,08	0,29	
89E32-010-2R	RH	[0.83]	[0.43]	[0.39]	[79]	[1.25]	[0.008]	[0.93]	89B/E32-2-00
89E32-010-2L	LH	21	11	10	350	32	0,22	0,42	
89E40-010-2R	RH	[0.94]	[0.55]		[130]	[1.57]	[0.014]	[1.76]	89B/E40-2-00
89E40-010-2L	LH	24	14		580	40	0,39	0,80	
89E50-025-2R	RH	[1.57]	[0.59]	[0.98]	[225]	[1.97]	[0.036]	[3.22]	89B/E50-2-00
89E50-025-2L	LH	40	15	25	1000	50	1,03	1,46	
89E63-008-2R	RH	[1.02]	[0.71]	[0.32]	[321]	[2.48]	[0.038]	[3.68]	89B/E63-2-00
89E63-008-2L	LH	26	18	8	1430	63	1,08	1,67	

† with standard clamping arm at 6bar [87psi]. ‡ per double stroke at 6bar [87psi]

**Operating Pressure Range:** 3bar [45psig] to 10bar [145psig] (89E20 8bar [116psig] max.)

**Maximum Operating Temperature:** 80°C [176°F]

# 89E SERIES

## Pneumatic Swing Clamps | Dimensions

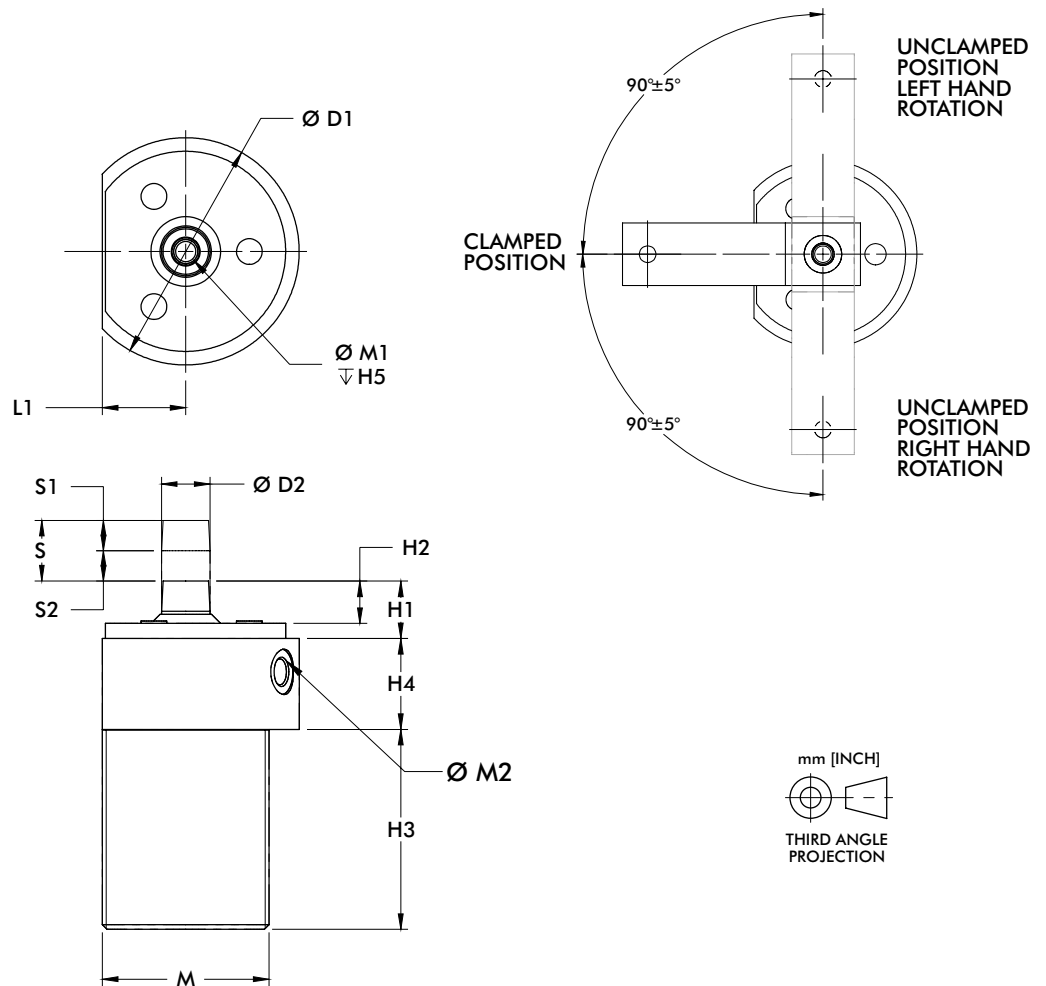

S = Total Stroke  
 S1 = Stroke during Rotation  
 S2 = Vertical Clamp Stroke

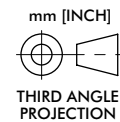

Model	ØD1	ØD2	H1	H2	H3	H4	H5	L1	M	M1	M2
89E20	[1.89] 48	[0.39] 10	[0.69] 17,5	[0.35] 9	[2.36] 60	[0.79] 20	[0.59] 15	[0.75] 19	M36X1,5	M5	M5
89E32	[2.52] 64	[0.47] 12	[0.63] 16	[0.43] 11	[2.72] 69		[0.67] 17	[0.89] 22,5	M42X1,5	M6	
89E40	[2.95] 75	[0.63] 16	[0.75] 19	[0.55] 14	[2.60] 66	[1.18] 30	[0.98] 25	[1.08] 27,5	M55X2	M8	G-1/8
89E50	[3.54] 90	[0.71] 18	[0.98] 25	[0.67] 17	[4.09] 104		[1.36] 34,5	M68X2	M10		
89E63	[4.13] 105	[0.79] 20	[1.06] 27	[0.75] 19	[3.03] 77		[1.57] 40	M80X2		G-1/4	

### Mounting Options

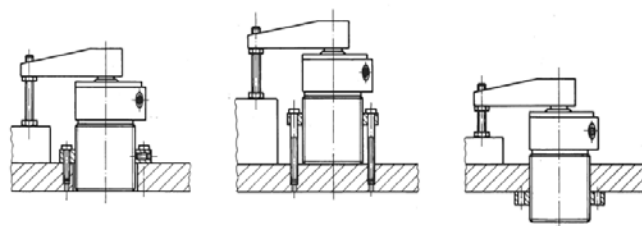

# 89E SERIES

## Pneumatic Swing Clamps | Clamping Forces

Series 89E Clamping Force  
(w/ standard clamping arm)

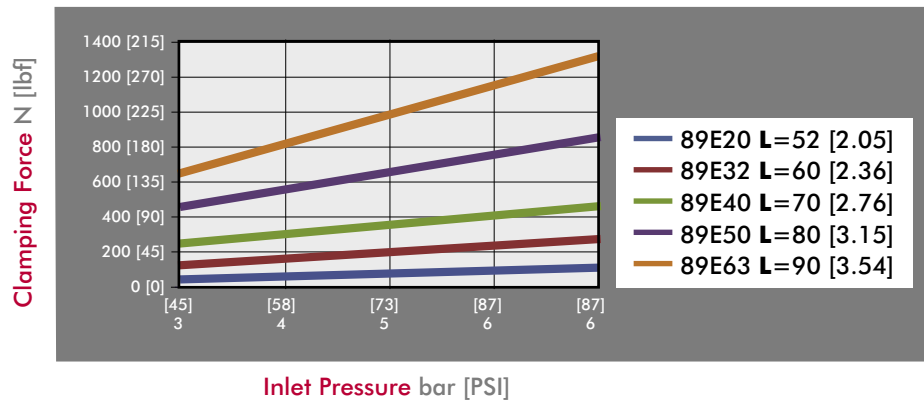

### Guidelines

DESTACO Pneumatic Swing Clamps are designed for long life when using standard clamping arms and spindles. In the event that a longer arm or additional weight is needed, please consult these charts for the allowable weight and length.

#### Example: 89E32

At a weight of 80 gr, the maximum length of the arm is approximately 90mm.

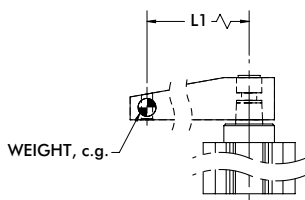

All data refers to an operating pressure of 5 bar [72psi] and an opening and closing time of 1 second.

89E20 & 89E32 Clamp Arm Weight

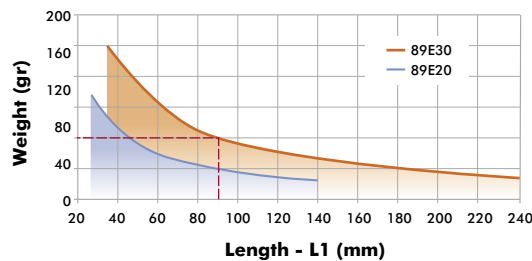

89E40 & 89E50 Clamp Arm Weight

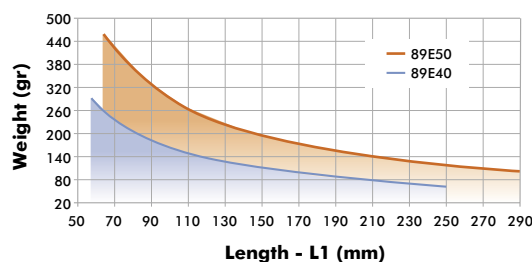

89E63 Clamp Arm Weight

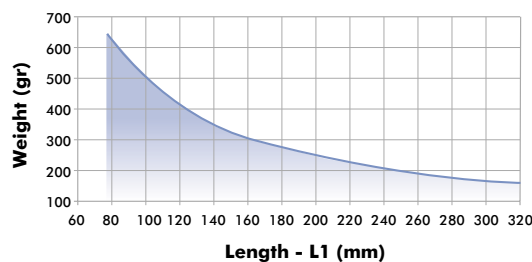

## Pneumatic Swing Clamps | Clamping Arms

### Features:

- Lightweight aluminum construction
- Locking tapered connection for 360 deg. arm positioning

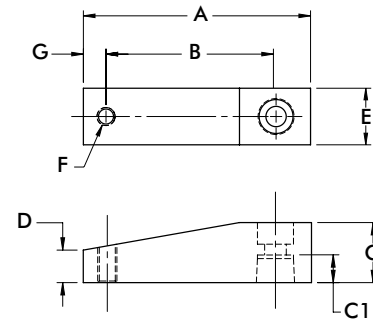

Part Number	Used with Model	A	B	C	C1	D	E	F	G	Weight [lbs] kg
8JG-215-1	89E20-010-2	[2.64] 67	[2.05] 52	[0.59] 15	[0.33] 8,5	[0.33] 8,5	[0.59] 15	M6	[0.28] 7	[0.08] 0,04
8JG-217-1	89E32-010-2	[3.15] 80	[2.36] 60	[0.79] 20	[0.37] 9,5		[0.79] 20	M8	[0.39] 10	[0.14] 0,06
8JG-218-1	89E40-010-2	[3.74] 95	[2.76] 70	[0.98] 25	[0.45] 11,5	[0.55] 14	[0.98] 25			[0.28] 0,13
8JG-219-1	89E50-025-2	[4.17] 106	[3.15] 80	[1.18] 30	[0.59] 15	[0.57] 14,5	[1.18] 30			[0.42] 0,19
8JG-220-1	89E63-008-2	[4.72] 120	[3.54] 90	[1.38] 35	[0.67] 17	[0.67] 17	[1.38] 35	M10	[0.47] 12	[0.66] 0,30

## Clamping Arm Adapters

### Features:

- For attaching custom made clamp arms
- 360° rotatable arm
- Aluminum construction

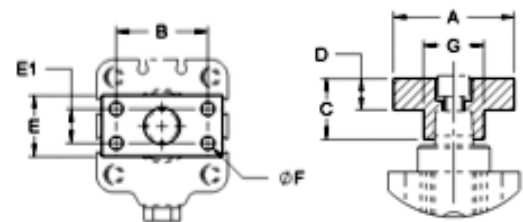
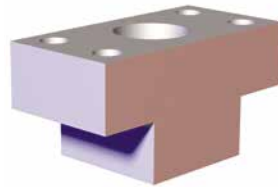

Part Number	Used with Model	A	B	C	D	E	E1	F	Weight [lbs] kg
8MA-084-1	89E20-010-2	[1.57] 40	[1.10] 28	[0.59] 15	[0.32] 8	[0.59] 15	--	[0.22] 5,5 (2x)	[0.03] 0,014
8MA-086-1	89E32-010-2	[1.97] 50	[1.38] 35	[0.79] 20	[0.43] 11	[0.79] 20	--	[0.22] 5,5 (4x)	[0.08] 0,035
8MA-087-1	89E40-010-2		[1.50] 38	[0.98] 25	[0.51] 13	[0.98] 25	[0.55] 14	[0.22] 7 (4x)	[0.11] 0,050
8MA-088-1	89E50-025-2	[2.36] 60	[1.77] 45	[1.18] 30	[0.59] 15	[1.18] 30	[0.59] 15	[0.28] 7 (4x)	[0.19] 0,085
8MA-089-1	89E63-008-2	[2.56] 65	[1.89] 48	[1.38] 35	[0.67] 17	[1.38] 35	[0.71] 18	[0.35] 9 (4x)	[0.28] 0,125

# 89E SERIES

## Pneumatic Swing Clamps | Mounting Flanges

### Features:

- For use with Threaded Body Pneumatic Swing Clamps
- Variable height adjustment
- For recessed mounting

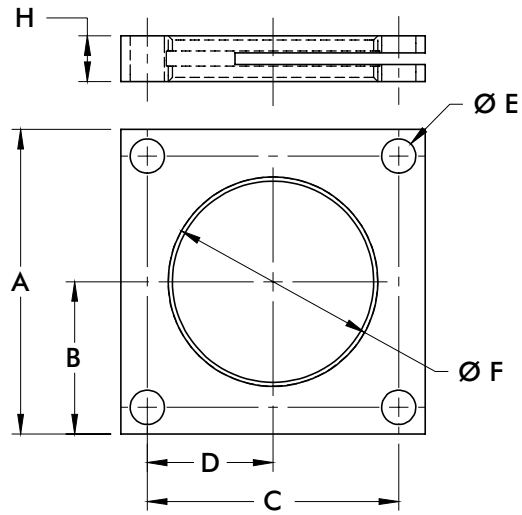
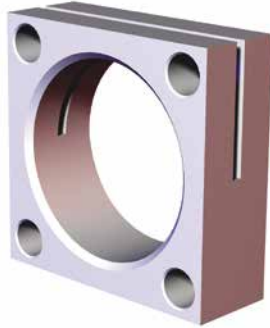

Part Number	Used with Model	A	B	C	D	E	F	H
8MA-219-1	89E20-010-2	[2.17] 55	[4.33] 27,5	[1.65] 42	[0.83] 21	[0.26] 6,6	M36X1,5	[0.31] 8
8MA-220-1	89E32-010-2	[2.76] 70	[1.38] 35	[2.13] 54	[1.06] 27	[0.35] 9	M42X1,5	[0.39] 10
8MA-221-1	89E40-010-2	[3.15] 80	[1.57] 40	[2.60] 66	[1.30] 33		M55X2	[0.47] 12
8MA-222-1	89E50-025-2	[3.54] 90	[1.77] 45	[2.99] 76	[1.50] 38	[0.43] 11	M68X2	[0.59] 15
8MA-223-1	89E63-008-2	[4.33] 110	[2.17] 55	[3.54] 90	[1.77] 45		M80X2	