

2013 SERIES

Horizontal Hold Down Clamps | Product Overview

Features:

- Increased handle clearance reduces pinch points
- Common mounting hole pattern to Model 213
- Fixed handle pivot provides smooth action
- Nearly 2 times the holding capacity Model 213
- BLK models feature a black, non-reflective finish

Applications:

- Checking fixtures
- Assembly & test
- Light machining
- Woodworking
- Closures

Also Available:

See page MC-ACC-1 for accessories
Accommodates M5 or #10 spindle accessory

Covered under one or more U.S./International Patents

2013-U
Flanged Base
U-Bar



2013-U-LS-BLK ⓘ
Blackout Series
Flanged Base
U-Bar



2013-UR
Flanged Base
U-Bar
DESTACO®
Toggle Lock
Plus™



ⓘ This item is available upon request

Technical Information

Model	Max. Holding Capacity	Clamp Bar Opening (+10°)	Handle Opening (+10°)	Weight	Accessories (Supplied)	
					Spindle Assembly	Flanged Washers
2013-U	1310 N [295 lbf]	71°	58°	0,17kg [0.37lb]	2013208-M	102111
2013-U-LS-BLK ⓘ					--	102111-BLK
2013-UR					2013208-M	102111

ⓘ This item is available upon request

Holding Capacities

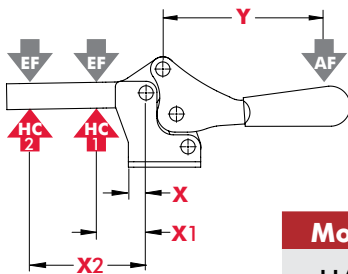

Model	X	X1	X2	Y	‡HC1	‡HC2	‡EF(X1):AF	‡EF(X2):AF
U/UR	[0.63] 16	[0.95] 24	[1.95] 49,5	[2.34] 59,5	[295lbf.] 1310N	[175lbf.] 780N	6:1	4:1

Dimensions shown "mm [inch]" ‡ HC = Holding Capacity, EF = Exerting Force, AF = Applied Force
See page MC-TEC-4 for additional information.

2013-U
Flanged Base
U-Bar

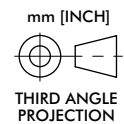
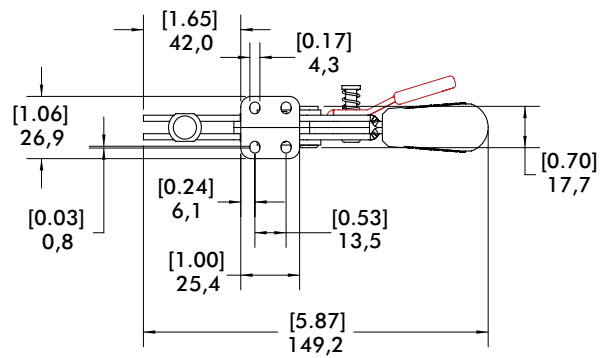
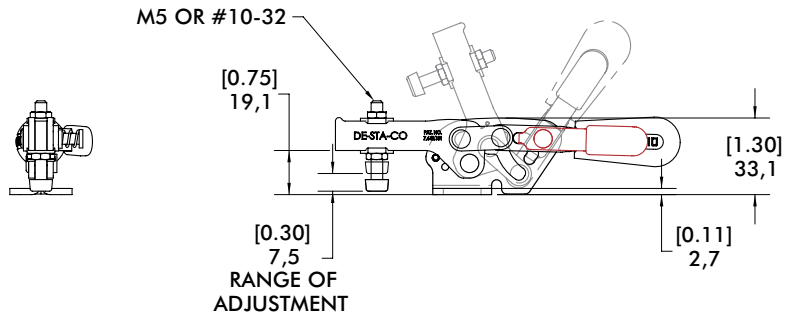
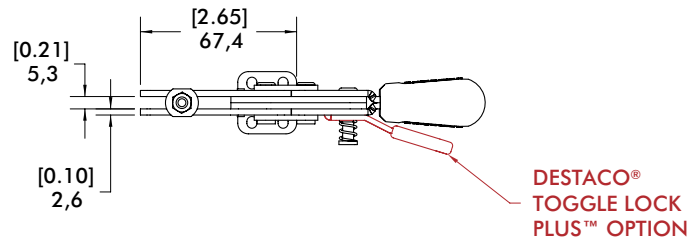

2017 SERIES

Horizontal Hold Down Clamps | Product Overview

Features:

- Increased handle clearance reduces pinch points
- Common mounting hole pattern to Model 217
- Fixed handle pivot provides smooth action
- Over 2½ times the holding capacity Model 217
- BLK models feature a black, non-reflective finish

Applications:

- Checking fixtures
- Assembly & test
- Light machining
- Woodworking
- Closures

Also Available:

See page MC-ACC-1 for accessories
Accommodates M6 or ¼" spindle accessory

Covered under one or more U.S./International Patents

2017-U
Flanged Base
U-Bar



2017-U-LS-BLK ⓘ
Blackout Series
Flanged Base
U-Bar



2017-UR
Flanged Base
U-Bar
DESTACO®
Toggle Lock
Plus™



ⓘ This item is available upon request

Technical Information

Model	Max. Holding Capacity	Clamp Bar Opening (+10°)	Handle Opening (+10°)	Weight	Accessories (Supplied)	
					Spindle Assembly	Flanged Washers
2017-U	2500 N [560 lbf]	73°	69°	0,44kg [0.97lb]	215208-M	215105
2017-U-LS-BLK ⓘ					--	215105-BLK
2017-UR					215208-M	215105

ⓘ This item is available upon request

Holding Capacities

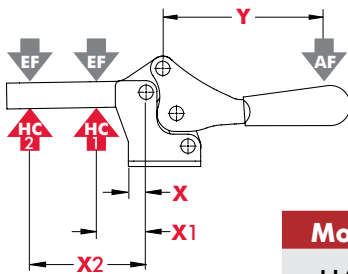

Model	X	X1	X2	Y	‡HC1	‡HC2	‡EF(X1):AF	‡EF(X2):AF
U/UR	[1.08] 27,4	[1.65] 42	[3.15] 80	[2.54] 64,5	[560lbf.] 2500N	[245lbf.] 1090N	5:1	2.5:1

Dimensions shown "mm [inch]" ‡ HC = Holding Capacity, EF = Exerting Force, AF = Applied Force
See page MC-TEC-4 for additional information.

2017-U
Flanged Base
U-Bar

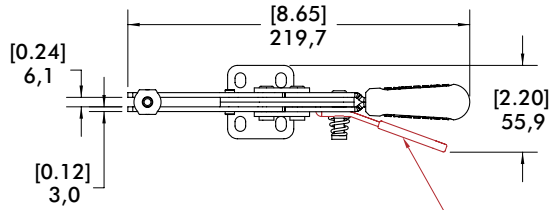

DESTACO®
TOGGLE LOCK
PLUS™ OPTION

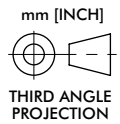
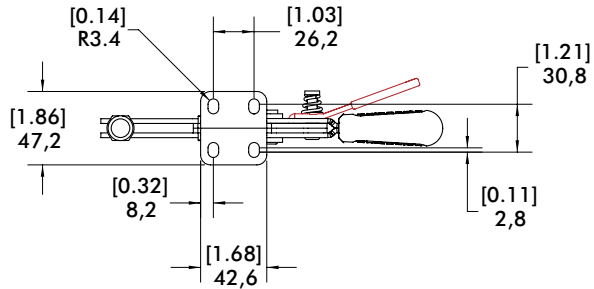
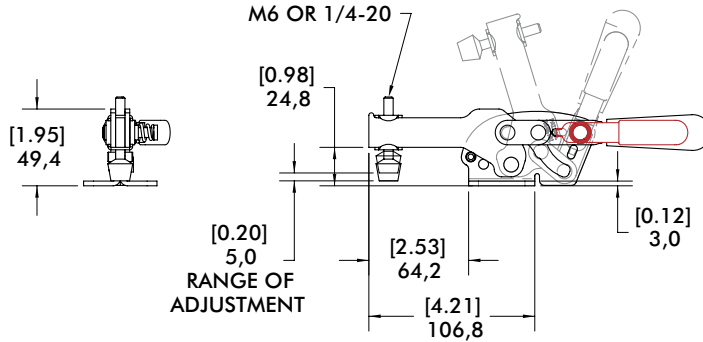

2027 SERIES

Horizontal Hold Down Clamps | Product Overview

Features:

- Increased handle clearance reduces pinch points
- Common mounting hole pattern to Model 227
- Fixed handle pivot provides smooth action
- Over 1½ times the holding capacity Model 227
- BLK models feature a black, non-reflective finish

Applications:

- Checking fixtures
- Assembly & test
- Light machining
- Woodworking
- Closures

Also Available:

See page MC-ACC-1 for accessories
Accommodates M8 or 5/16" spindle accessory

Covered under one or more U.S./International Patents

2027-U
Flanged Base
U-Bar



2027-U-LS-BLK ⓘ
Blackout Series
Flanged Base
U-Bar



2027-UR
Flanged Base
U-Bar
DESTACO®
Toggle Lock
Plus™



ⓘ This item is available upon request

Technical Information

Model	Max. Holding Capacity	Clamp Bar Opening (+10°)	Handle Opening (+10°)	Weight	Accessories (Supplied)	
					Spindle Assembly	Flanged Washers
2027-U					2007208-M	507107
2027-U-LS-BLK ⓘ	3740 N [840 lbf]	68°	70°	0,61 kg [1.34lb]	--	507107-BLK
2027-UR					2007208-M	507107

ⓘ This item is available upon request

Holding Capacities

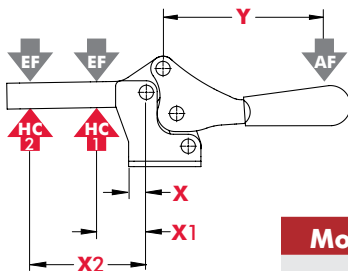

Model	X	X1	X2	Y	‡HC1	‡HC2	‡EF(X1):AF	‡EF(X2):AF
U/UR	[1.02] 25,8	[1.75] 44,5	[3.30] 83,8	[2.54] 64,5	[840lbf.] 3740N	[480lbf.] 2140N	5:1	3:1

Dimensions shown "mm [inch]" ‡ HC = Holding Capacity, EF = Exerting Force, AF = Applied Force
See page MC-TEC-4 for additional information.

2027-U
Flanged Base
U-Bar

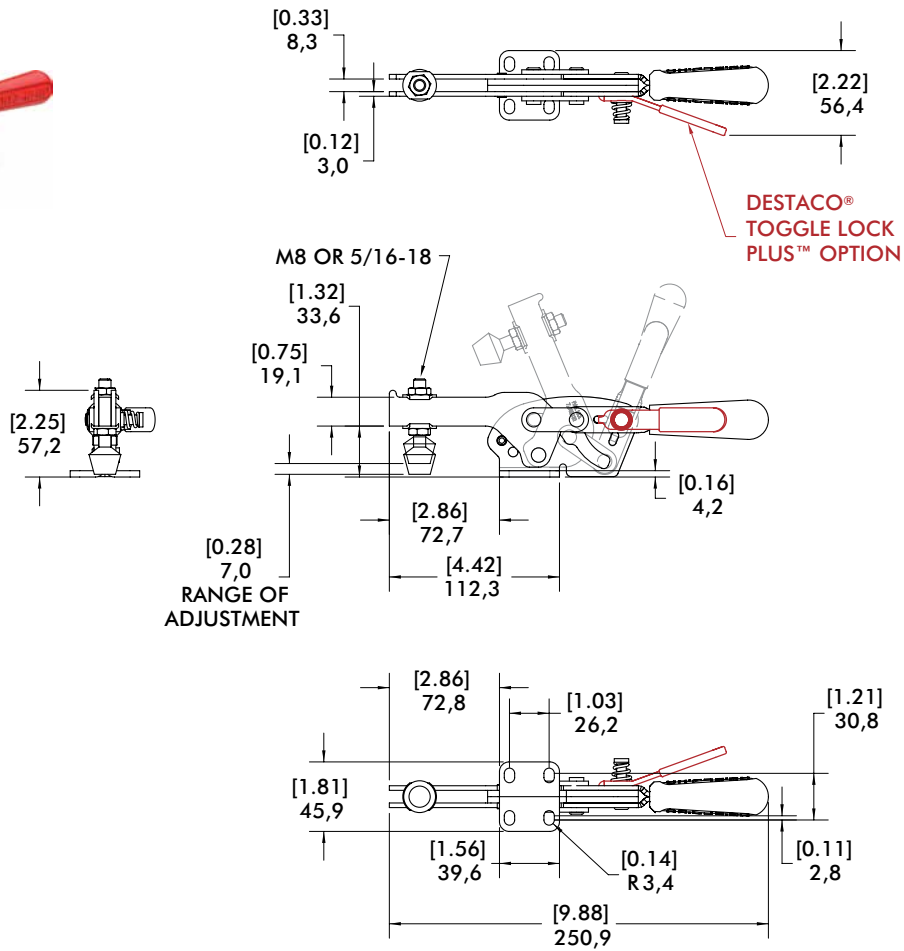

213 SERIES

Horizontal Hold Down Clamps | Product Overview

Features:

- Low profile
- Large handle clearance in the open position
- Available in stainless steel
- BLK models feature a black, non-reflective finish

Applications:

- Assembly
- Checking fixtures
- Closures
- Woodworking

Also Available:

See page MC-ACC-1 for accessories
Accommodates M5 or #10 spindle accessory

213-U/USS
Flanged Base
U-Bar



-USS Stainless Steel Model



213-U-LS-BLK ⓘ
Blackout Series
Flanged Base
U-Bar



213-UB
Straight Base
U-Bar



213-UB-LS-BLK ⓘ
Blackout Series
Straight Base
U-Bar



213-U-L ⓘ
Flanged Base
Open Bar



213-U-L-BLK ⓘ
Flanged Base
Open Bar



213-UB-L ⓘ
Straight Base
Open Bar



213-UB-L-BLK ⓘ
Blackout Series
Straight Base
Open Bar



ⓘ This item is available upon request

Technical Information

Model	Max. Holding Capacity	Clamp Bar Opening (+10°)	Handle Opening (+10°)	Weight	Accessories (Supplied)	
					Spindle Assembly	Flanged Washers
213-U	670 N [150 lbf]	90°	60°	0,08kg [0.17lb]	213208-M	102111
213-U-LS-BLK ⓘ					--	102111-BLK
213-USS					201943-M	102911
213-UB					213208-M	102111
213-UB-LS-BLK ⓘ					--	102111-BLK
213-U-L ⓘ						102111
213-U-L-BLK ⓘ						102111-BLK
213-UB-L ⓘ						102111
213-UB-L-BLK ⓘ						102111-BLK

ⓘ This item is available upon request

213 SERIES

Horizontal Hold Down Clamps | Holding Capacities

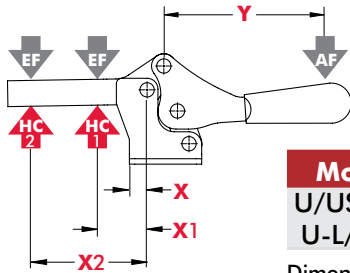

Model	X	X1	X2	Y	±HC1	±HC2	±EF(X1):AF	±EF(X2):AF
U/USS/UB	[0.36]	[0.75]	[1.63]	[1.81]	[150lbf.]	[70lbf.]	7:1	3:1
U-L/UB-L	9,3	19	41,4	46	670N	310N		

Dimensions shown "mm [inch]" ± HC = Holding Capacity, EF = Exerting Force, AF = Applied Force
See page MC-TEC-4 for additional information.

Dimensions | -U/-USS/-UB

213-U Flanged Base U-Bar

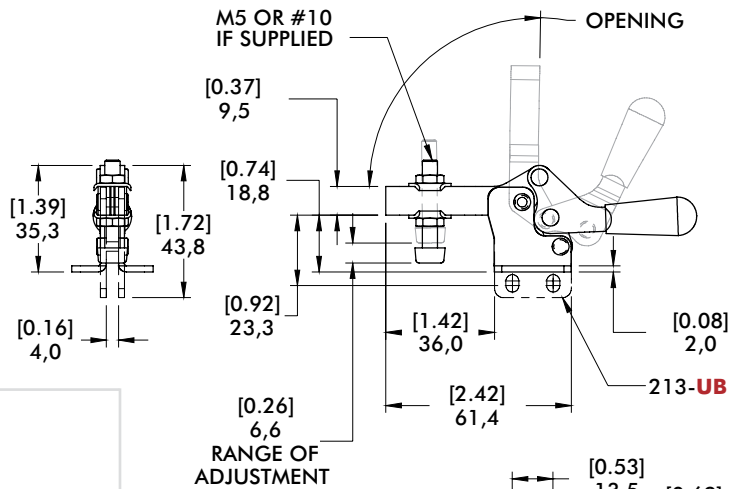
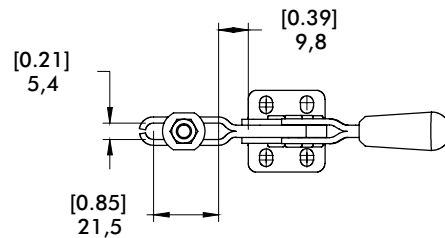

Series 213 Open Bar Options



Flanged Base Model 213-U-L ⓘ

See page MC-ACC-7 for Complete offering of Open bar accessories

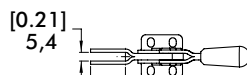

Straight Base Model 213-UB-L ⓘ

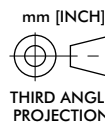
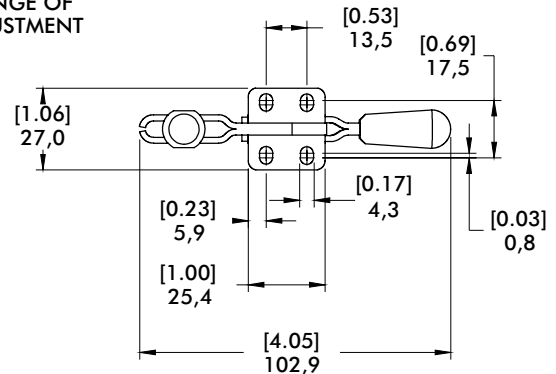
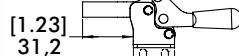

217 SERIES

Horizontal Hold Down Clamps | Product Overview

Features:

- Low profile
- Large handle clearance in the open position
- Available in stainless steel
- BLK models feature a black, non-reflective finish

Applications:

- Assembly
- Checking fixtures
- Closures
- Woodworking

Also Available:

See page MC-ACC-1 for accessories
Accommodates M6 or 1/4" spindle accessory

217-U/USS
Flanged Base
U-Bar



-USS Stainless Steel Model



217-U-LS-BLK ⓘ
Blackout Series
Flanged Base
U-Bar



217-UB
Straight Base
U-Bar



217-UB-LS-BLK ⓘ
Blackout Series
Straight Base
U-Bar



217-U-L ⓘ
Flanged Base
Open Bar



217-U-L-BLK ⓘ
Flanged Base
Open Bar



217-UB-L ⓘ
Straight Base
Open Bar



217-UB-L-BLK ⓘ
Blackout Series
Straight Base
Open Bar



ⓘ This item is available upon request

Technical Information

Model	Max. Holding Capacity	Clamp Bar Opening (+10°)	Handle Opening (+10°)	Weight	Accessories (Supplied)		
					Spindle Assembly	Flanged Washers	
217-U	900 N [200 lbf]	91°	61°	0,18kg [0.40lb]	202208-M	215105	
217-U-LS-BLK ⓘ					--	215105-BLK	
217-USS	1110 N [250 lbf]				202943-M	215105	
217-UB					202208-M	215105	
217-UB-LS-BLK ⓘ						215105-BLK	
217-U-L ⓘ	900 N [200 lbf]					215105	
217-U-L-BLK ⓘ						--	215105-BLK
217-UB-L ⓘ						215105	
217-UB-L-BLK ⓘ			215105-BLK				

ⓘ This item is available upon request

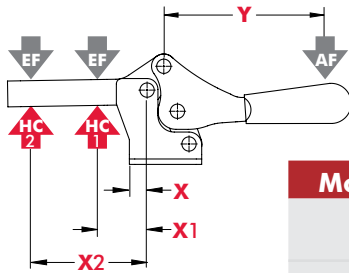

Model	X	X1	X2	Y	±HC1	±HC2	±EF(X1):AF	±EF(X2):AF
U					[200lbf.] 900N	[80lbf.] 360N		
USS	[0.53] 13,5	[1.13] 28,6	[2.63] 66,8	[2.93] 74,5	[250lbf.] 1110N	[100lbf.] 440N	7:1	3:1
UB/U-L/ UB-L					[200lbf.] 900N	[80lbf.] 360N		

Dimensions shown "mm [inch]" ± HC = Holding Capacity, EF = Exerting Force, AF = Applied Force
See page MC-TEC-4 for additional information.

Dimensions | -U/-USS/-UB

Series 217 Open Bar Options



Flanged Base
Model
217-U-L



Straight Base
Model
217-UB-L

See page MC-ACC-7 for
Complete offering of
Open bar accessories

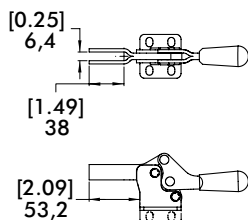

217-U Flanged Base U-Bar

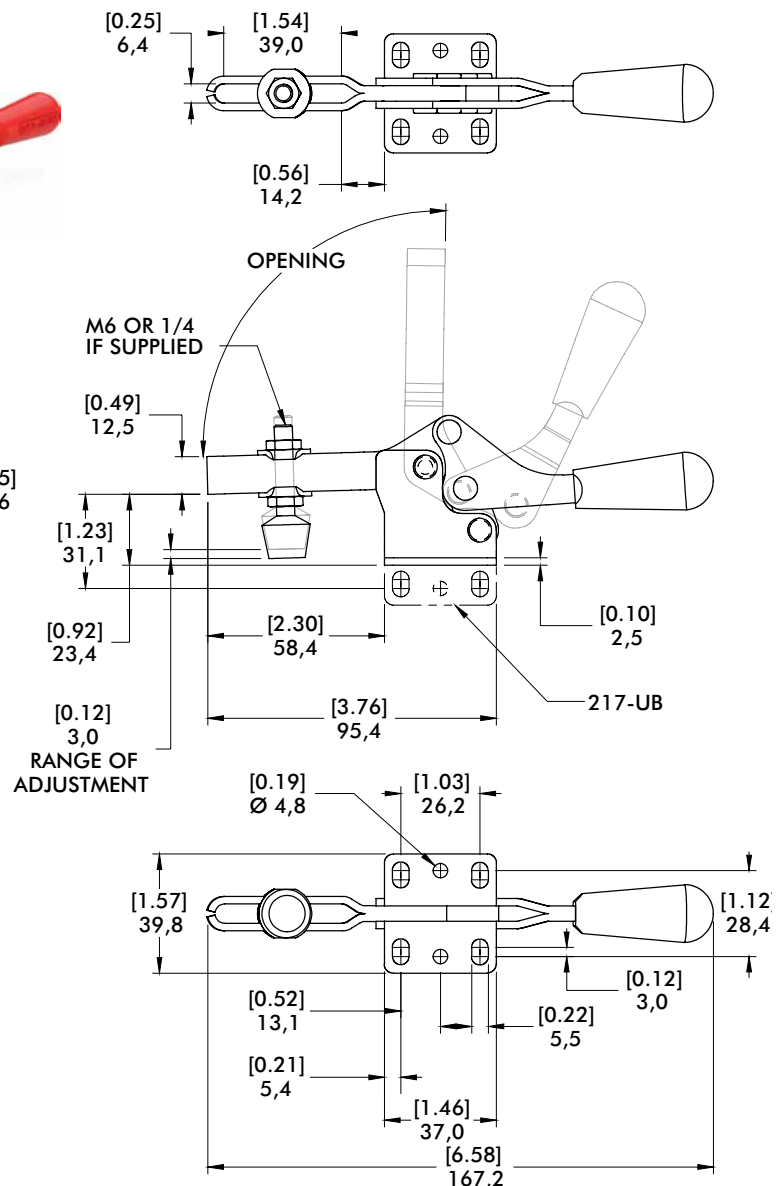
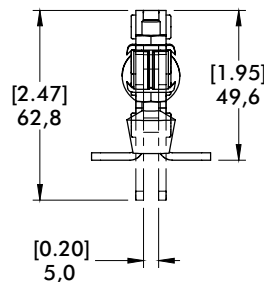

mm [INCH]
THIRD ANGLE
PROJECTION

227 SERIES

Horizontal Hold Down Clamps | Product Overview

Features:

- Low profile
- Large handle clearance in the open position.
- Available in stainless steel
- BLK models feature a black, non-reflective finish

Applications:

- Assembly
- Checking fixtures
- Closures
- Woodworking

Also Available:

See page MC-ACC-1 for accessories
Accommodates M6 or 5/16" spindle accessory

227-U/USS
Flanged Base
U-Bar



-USS Stainless Steel Model



227-U-LS-BLK ⓘ
Blackout Series
Flanged Base
U-Bar



227-UB
Straight Base
U-Bar



227-UB-LS-BLK ⓘ
Blackout Series
Straight Base
U-Bar



227-U-L ⓘ
Flanged Base
Open Bar



227-U-L-BLK ⓘ
Flanged Base
Open Bar



227-UB-L ⓘ
Straight Base
Open Bar



227-UB-L-BLK ⓘ
Blackout Series
Straight Base
Open Bar



ⓘ This item is available upon request

Technical Information

Model	Max. Holding Capacity	Clamp Bar Opening (+10°)	Handle Opening (+10°)	Weight	Accessories (Supplied)	
					Spindle Assembly	Flanged Washers
227-U	2220 N [500 lbf]	91°	56°	0,31 kg [0.68lb]	225208-M	507107
227-U-LS-BLK ⓘ					--	507107-BLK
227-USS	2670 N [600 lbf]				-207943-M	507907
227-UB	2220 N [500 lbf]				225208-M	507107
227-UB-LS-BLK ⓘ					--	507107-BLK
227-U-L ⓘ					--	507107
227-U-L-BLK ⓘ					--	507107-BLK
227-UB-L ⓘ					--	507107
227-UB-L-BLK ⓘ		--	507107-BLK			

ⓘ This item is available upon request

227 SERIES

Horizontal Hold Down Clamps | Holding Capacities

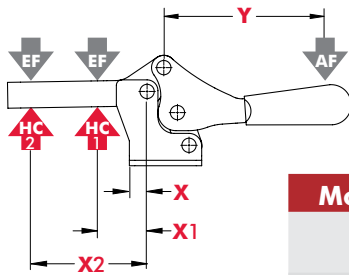

Model	X	X1	X2	Y	±HC1	±HC2	±EF(X1):AF	±EF(X2):AF
U					[500lbf.] 2220N	[225lbf.] 1000N		
USS	[0.39] 10,0	[1.25] 31,8	[2.75] 70,0	[3.58] 91,0	[600lbf.] 2670N	[270lbf.] 1200N	8:1	3:1
UB/U-L/ UB-L					500lbf.] 2220N	[225lbf.] 1000N		

Dimensions shown "mm [inch]" ± HC = Holding Capacity, EF = Exerting Force, AF = Applied Force
See page MC-TEC-4 for additional information.

Dimensions | -U/-USS/-UB

227-U
Flanged Base
U-Bar

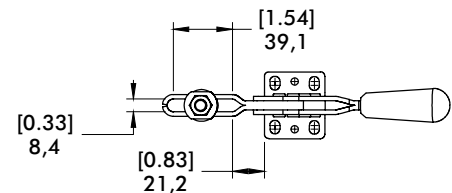

Series 227 Open Bar Options



Flanged Base
Model
227-U-L

See page MC-ACC-7 for Complete offering of Open bar accessories

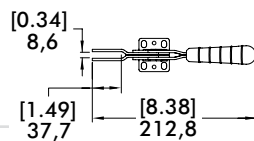

Straight Base
Model
227-UB-L

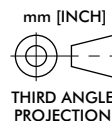
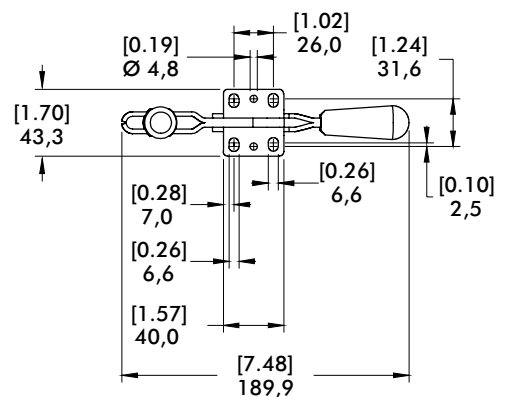
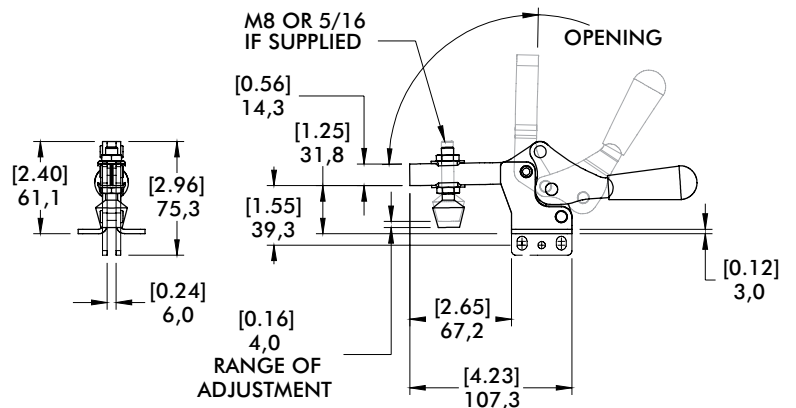
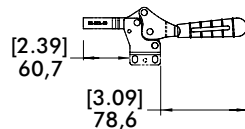

237 SERIES

Horizontal Hold Down Clamps | Product Overview

Features:

- Low profile
- Large handle clearance in the open position.
- Available in stainless steel

Applications:

- Assembly
- Checking fixtures
- Welding

Also Available:

See page MC-ACC-1 for accessories
Accommodates M10 or 3/8" spindle accessory

237-U/USS Flanged Base U-Bar



-USS Stainless Steel Model



Technical Information

Model	Max. Holding Capacity	Clamp Bar Opening(+10°)	Handle Opening (+10°)	Weight	Accessories (Supplied)	
					Spindle Assembly	Flanged Washers
237-U	3340 N [750 lbf]	93°	59°	0,73kg [1.60lb]	240208-M	235106
237-USS ⓘ	3780 N [850 lbf]				237943-M	235906

ⓘ This item is available upon request

Holding Capacities

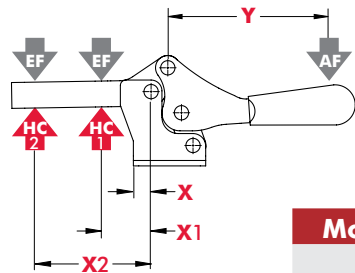

Model	X	X1	X2	Y	±HC1	±HC2	±EF(X1):AF	±EF(X2):AF
U	[0.81]	[1.75]	[4.50]	[5.25]	[750lbf.] 3340N	[290lbf.] 1290N	6:1	2:1
USS	20,6	44,5	114,3	133,3	[850lbf.] 3780N	[330lbf.] 1470N		

Dimensions shown "mm [inch]" ± HC = Holding Capacity, EF = Exerting Force, AF = Applied Force
See page MC-TEC-4 for additional information.

237-U
Flanged Base
U-Bar

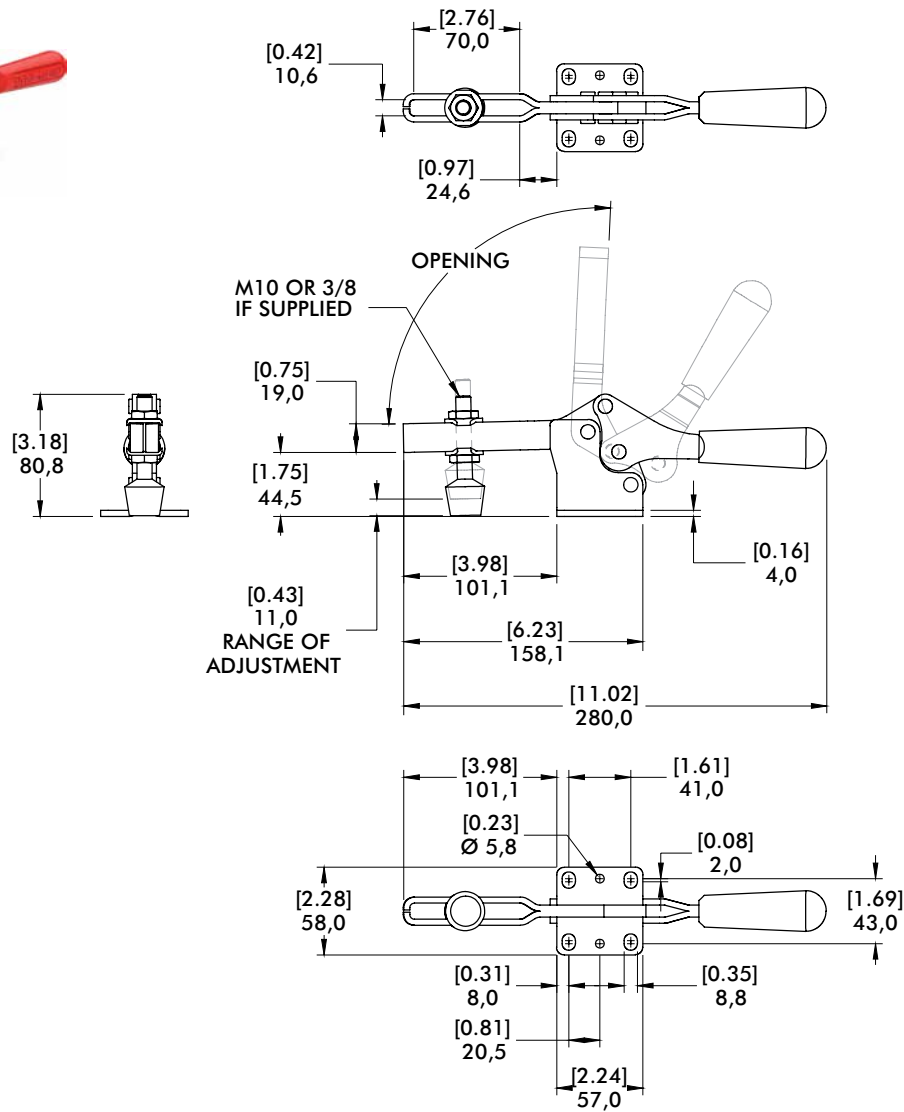

245 SERIES

Horizontal Hold Down Clamps | Product Overview

Features:

- Low profile
- Large handle clearance in the open position.

Applications:

- Assembly
- Checking fixtures
- Welding

Also Available:

See page MC-ACC-1 for accessories
Accommodates M12 or 1/2" spindle accessory

245-U
Flanged Base
U-Bar



Technical Information

Model	Max. Holding Capacity	Clamp Bar Opening (+10°)	Handle Opening (+10°)	Weight	Accessories (Supplied)	
					Spindle Assembly	Flanged Washers
245-U	4450 N [1000 lbf]	105°	74°	1,32kg [2.90lb]	247208-M	247109

Holding Capacities

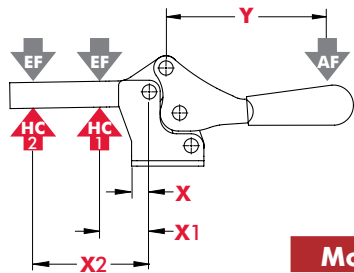

Model	X	X1	X2	Y	±HC1	±HC2	±EF(X1):AF	±EF(X2):AF
U	[0.50] 12,7	[2.00] 50,8	[5.00] 127	[6.09] 154,7	[1000lbf.] 4450N	[400lbf.] 1780N	11:1	5:1

Dimensions shown "mm [inch]" ‡ **HC** = Holding Capacity, **EF** = Exerting Force, **AF** = Applied Force
See page MC-TEC-4 for additional information.

245-U Flanged Base U-Bar

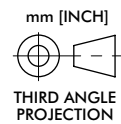
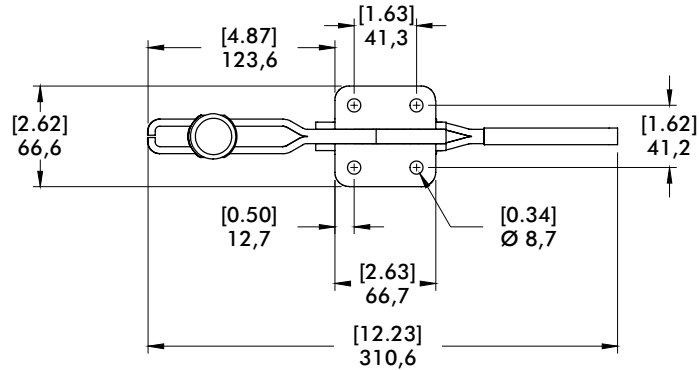
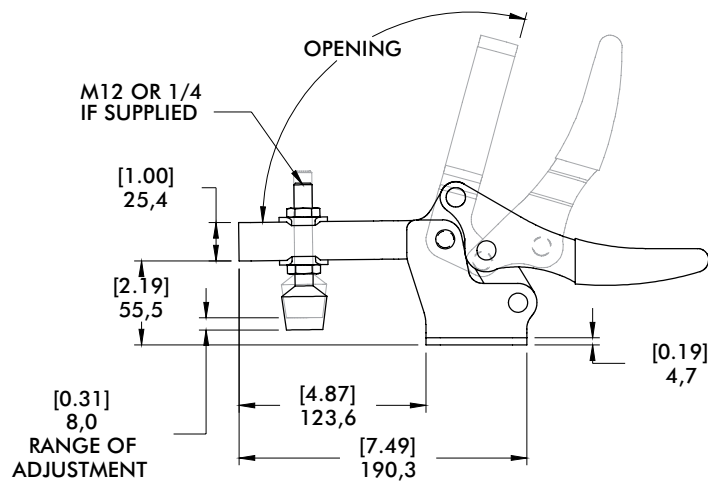
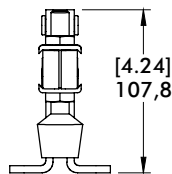
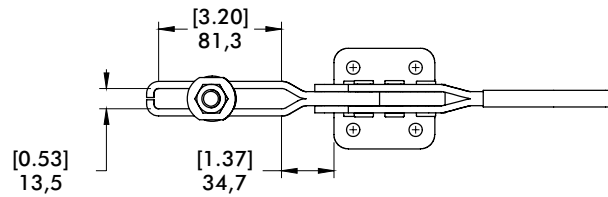

205 SERIES

Horizontal Hold Down Clamps | Product Overview

Features:

- Smallest of the Horizontal Hold Down clamps
- Ideal for light duty clamping in tight spaces
- Stainless steel models furnished without plastic grip

Applications:

- Assembly
- Closures
- Woodworking
- Light duty clamping

Also Available:

See page MC-ACC-1 for accessories
Accommodates M4 or #8 spindle accessory

205-U/USS
Flanged Base
U-Bar



-USS Stainless Steel Model

205-UB ⓘ
Straight Base
U-Bar



205-UL ⓘ
Left Flanged Base
U-Bar



205-UR ⓘ
Right Flanged Base
U-Bar



205-S/SSS
Flanged Base
Solid Bar



-USS Stainless Steel Model

205-SB ⓘ
Straight Base
Solid Bar



205-SL ⓘ
Left Flanged Base
Solid Bar



205-SR ⓘ
Right Flanged Base
Solid Bar



Technical Information

Model	Max. Holding Capacity	Clamp Bar Opening (+10°)	Handle Opening (+10°)	Weight	Accessories (Supplied)		
					Spindle Assembly	Flanged Washers	
205-U	270N [60 lbf]	90°	80°	0,03kg [0.06lb]	205208-M	105106	
205-UB ⓘ							
205-UL ⓘ							
205-UR ⓘ	340N [75 lbf]	94°	82°		205943-M	105906	
205-USS							
205-S							
205-SB ⓘ	270N [60 lbf]	94°	82°	205208-M	--		
205-SL ⓘ							
205-SR ⓘ							
205-SSS	340N [75 lbf]					205943-M	

ⓘ This item is available upon request

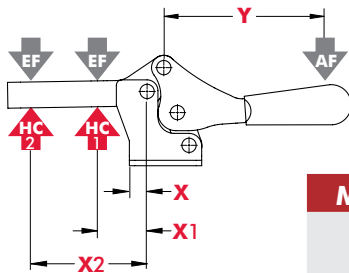

Model	X	X1	X2	Y	±HC1	±HC2	±EF(X1):AF	±EF(X2):AF
U		[0.43] 11			[60lbf.] 270N	[50lbf.] 220N	9:1	5:1
USS	[0.22] 5,6		[0.81] 20,5	[1.31] 33,2	[75lbf.] 340N	[65lbf.] 290N		
S		--			--	[60lbf.] 270N	--	4:1
SSS						[75lbf.] 340N		

Dimensions shown "mm [inch]" ± HC = Holding Capacity, EF = Exerting Force, AF = Applied Force
See page MC-TEC-4 for additional information.

Dimensions | -U/-UB/-UL-/-UR/-USS/-S/-SB/-SL/-SR/-SSS

205-U
Flanged Base
U-Bar

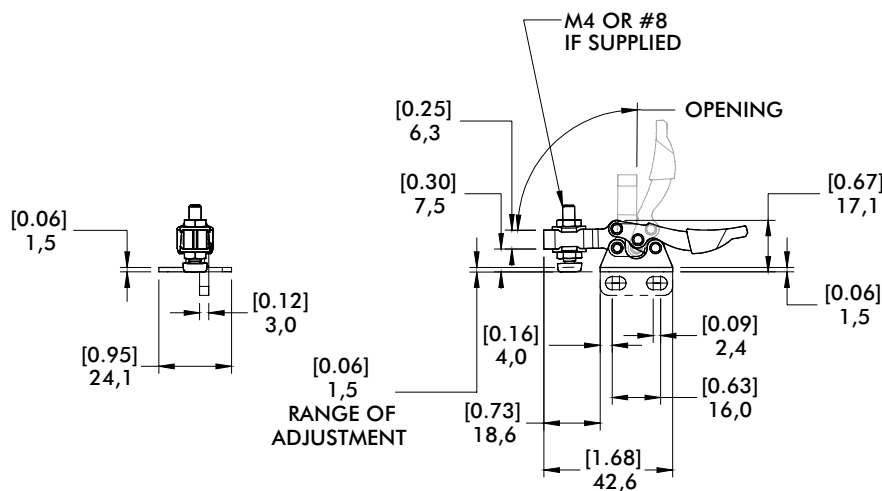
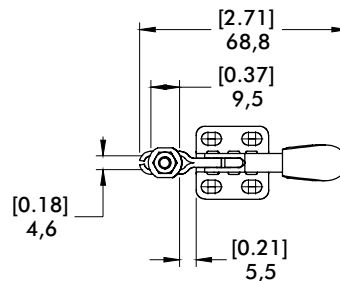

205-S
Flanged Base
Solid Bar

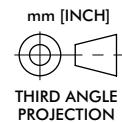
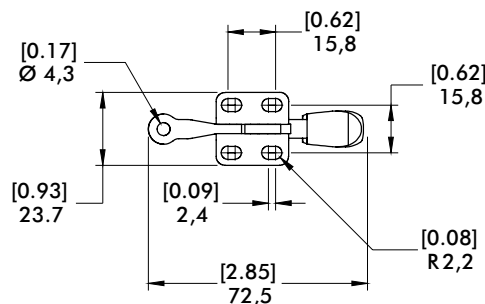

215 SERIES

Horizontal Hold Down Clamps | Product Overview

Features:

- Low profile
- Stainless steel model furnished without plastic grip

Applications:

- Assembly
- Checking fixtures
- Closures
- Woodworking

Also Available:

See page MC-ACC-1 for accessories
Accommodates M6 or 1/4" spindle accessory

215-U/USS
Flanged Base
U-Bar



-USS Stainless Steel Model

215-UB ⓘ
Straight Base
U-Bar



215-S
Flanged Base
Solid Bar



Technical Information

Model	Max. Holding Capacity	Clamp Bar Opening (+10°)	Handle Opening (+10°)	Weight	Accessories (Supplied)		
					Spindle Assembly	Flanged Washers	Bolt Retainer
215-U	890 N [200 lbf]	87°	78°	0,15kg [0.34lb]	202208-M	215105	--
215-USS	1110 N [250 lbf]				202943-M	215905	
215-UB ⓘ	890 N [200 lbf]				202208-M	215105	
215-S					--	--	205105

ⓘ This item is available upon request

Holding Capacities

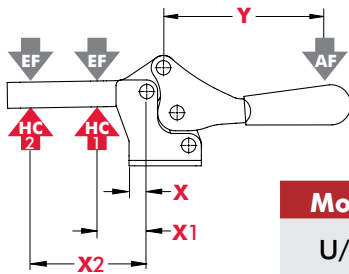

Model	X	X1	X2	Y	±HC1	±HC2	±EF(X1):AF	±EF(X2):AF
U/UB		[1.00] 25,4	[2.25] 57		[200lbf.] 890N	[80lbf.] 360N	9:1	4:1
USS	[0.22] 5,6			[2.72] 69	[250lbf.] 1110N	[110lbf.] 490N		
S		[1.63] 41,4	[2.88] 73		[200lbf.] 890N		6:1	

Dimensions shown "mm [inch]" ± HC = Holding Capacity, EF = Exerting Force, AF = Applied Force
See page MC-TEC-4 for additional information.

215-U
Flanged Base
U-Bar

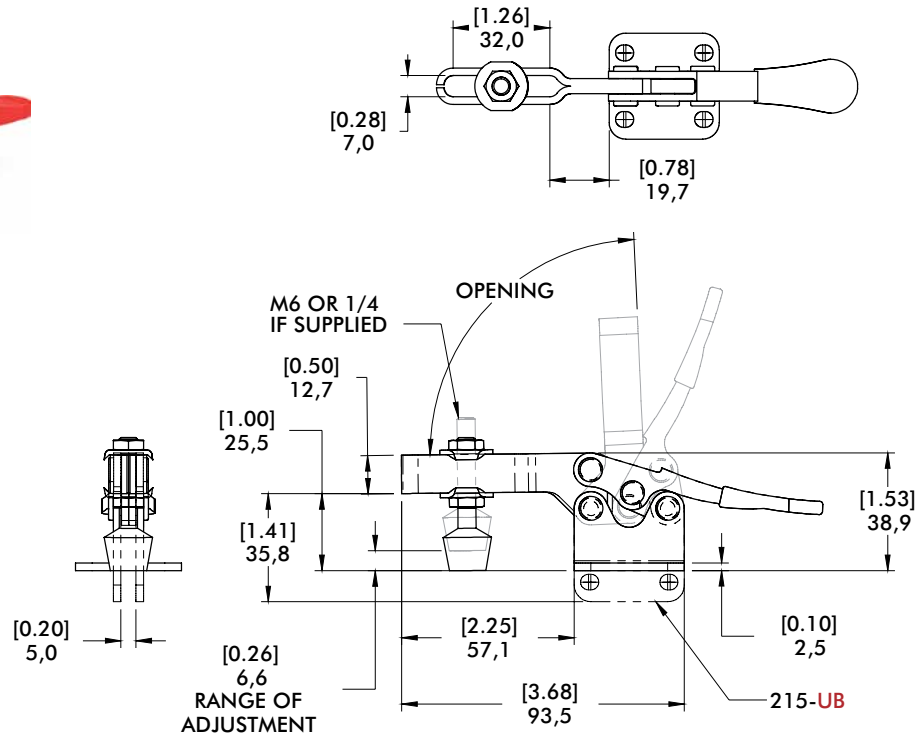

215-S
Flanged Base
Solid Bar

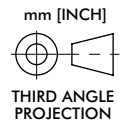
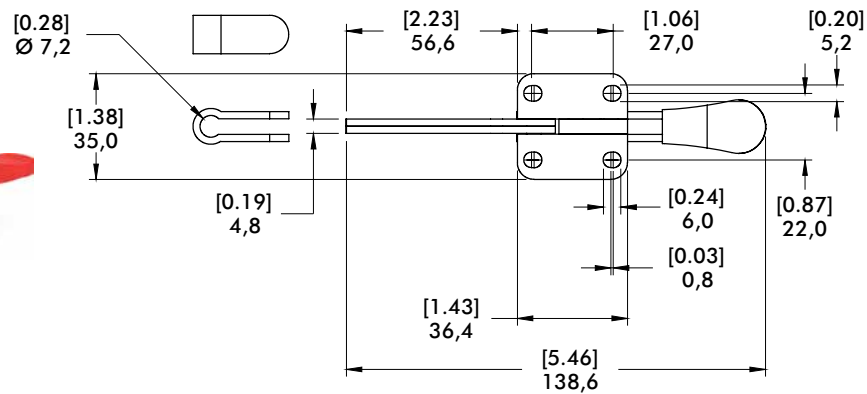

225 SERIES

Horizontal Hold Down Clamps | Product Overview

Features:

- Low profile
- Stainless steel model furnished without plastic grip
- Available DESTACO® Toggle Lock Plus™

Applications:

- Assembly
- Checking fixtures
- Closures
- Woodworking

Also Available:

See page MC-ACC-1 for accessories
Accommodates M8 or 5/16" spindle accessory

Covered under one or more U.S./International Patents

225-U/USS Flanged Base U-Bar



225-UR/URSS Flanged Base U-Bar DESTACO® Toggle Lock Plus



225-UB/UBSS ① Straight Base U Bar



Technical Information

Model	Max. Holding Capacity	Clamp Bar Opening (+10°)	Handle Opening (+10°)	Weight	Accessories (Supplied)	
					Spindle Assembly	Flanged Washers
225-U	2220 N [500 lbf]	92°	70°	0,25kg [0.55lb]	225208-M	507107
225-USS	2670 N [600 lbf]				207943-M	507907
225-UR	2220 N [500 lbf]			0,31kg [0.69lb]	225208-M	507107
225-URSS	2670 N [600 lbf]				207943-M	507907
225-UB ①	2220 N [500 lbf]			0,25kg [0.55lb]	225208-M	507107
225-UBSS ①	2670 N [600 lbf]				207943-M	507907

① This item is available upon request

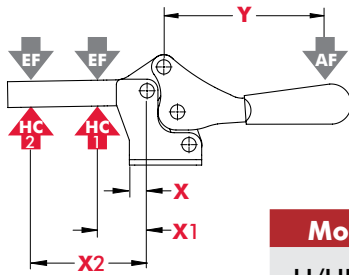

Model	X	X1	X2	Y	±HC1	±HC2	±EF(X1):AF	±EF(X2):AF
U/UR/UB	[0.12]	[1.25]	[2.50]	[3.56]	[500lbf.] 2220N	[250lbf.] 1110N	12:1	5:1
USS/URSS/ UBSS	3,0	31,8	63,5	90,4	[600lbf.] 2670N	[300lbf.] 1340N		

Dimensions shown "mm [inch]" ± HC = Holding Capacity, EF = Exerting Force, AF = Applied Force
See page MC-TEC-4 for additional information.

Dimensions | -U/-USS-/UB-/UBSS

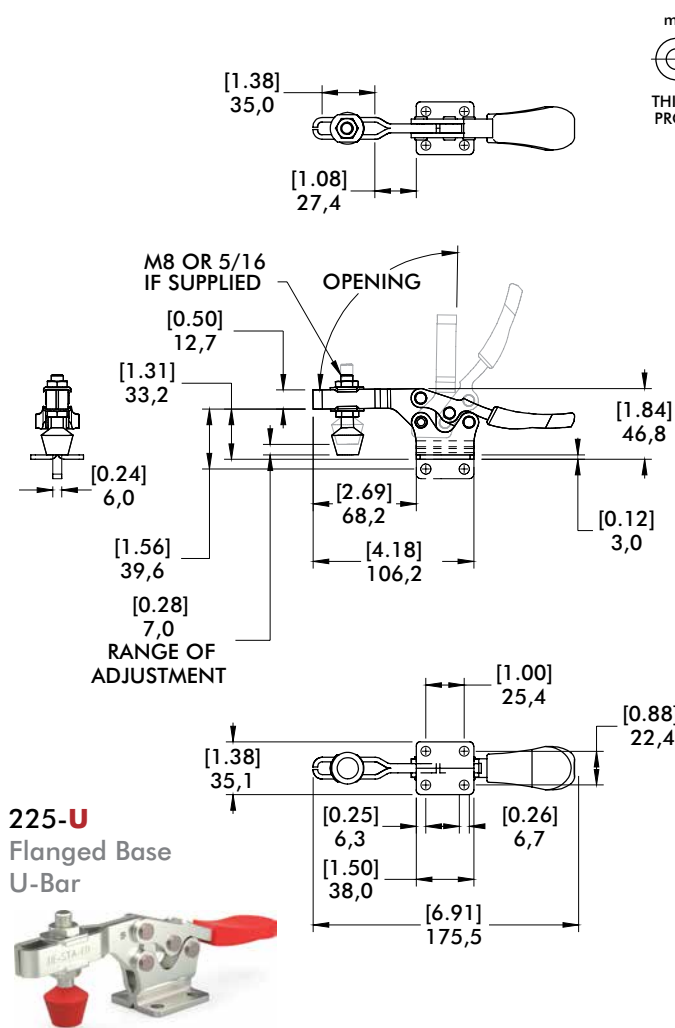

Dimensions | -UR/-URSS

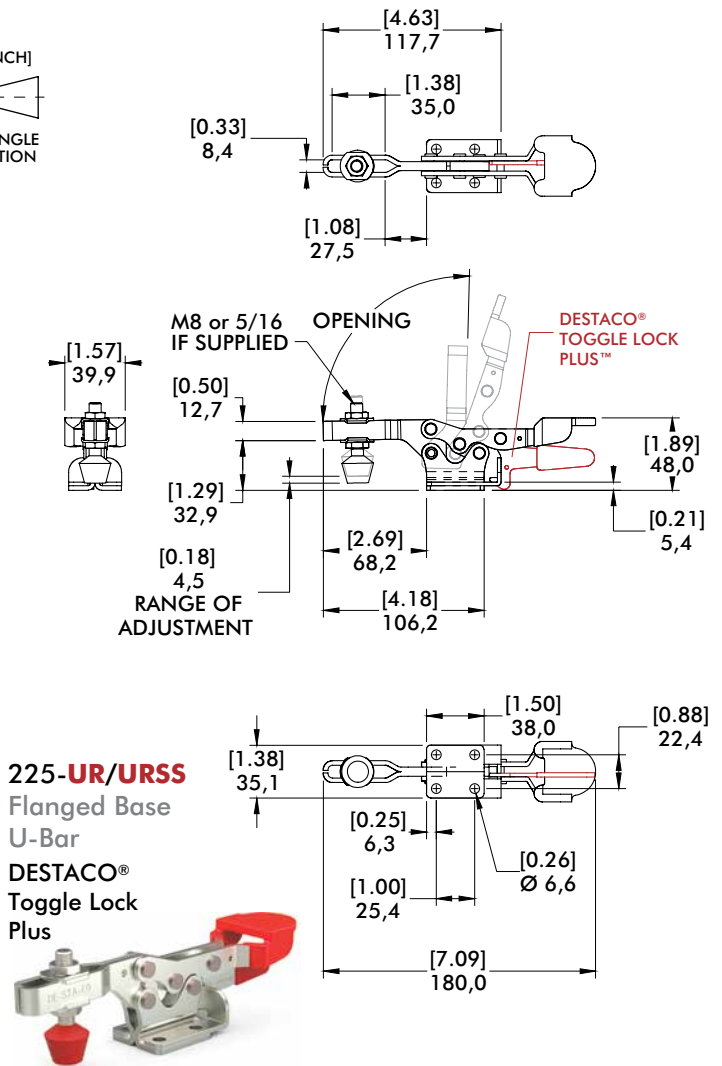

235 SERIES

Horizontal Hold Down Clamps | Product Overview

Features:

- Low profile
- Available DESTACO® Toggle Lock Plus™
- Available in stainless steel

Applications:

- Assembly
- Checking fixtures
- Welding
- Closures
- Woodworking

Also Available:

See page MC-ACC-1 for accessories
Accommodates M10 or 3/8" spindle accessory

Covered under one or more U.S./International Patents

235-U/USS
Flanged Base
U-Bar



-USS Stainless Steel Model



235-UR/URSS
Flanged Base
U-Bar



-URSS Stainless Steel Model

DESTACO®
Toggle Lock
Plus



235-UB ⓘ
Straight Base
U Bar



Technical Information

Model	Max. Holding Capacity	Clamp Bar Opening (+10°)	Handle Opening (+10°)	Weight	Accessories (Supplied)	
					Spindle Assembly	Flanged Washers
235-U	3340 N [750 lbf]	92°	70°	0,67kg [1.47lb]	240208-M	235106
235-USS	3780 N [850 lbf]				237943-M	235906
235-UR	3340 N [750 lbf]			240208-M	235106	
235-URSS	3780 N [850 lbf]			237943-M	235906	
235-UB ⓘ	3340 N [750 lbf]			240208-M	235106	

ⓘ This item is available upon request

Holding Capacities

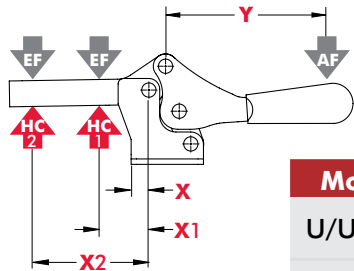

Model	X	X1	X2	Y	±HC1	±HC2	±EF(X1):AF	±EF(X2):AF
U/UR/UB	[0.25]	[1.75]	[4.13]	[5.75]	[750lbf.] 3340N	[300lbf.] 1330N	9:1	5:1
USS/URSS	6,4	44,5	105	146	[850lbf.] 3780N	[360lbf.] 1600N		

Dimensions shown "mm [inch]" ± HC = Holding Capacity, EF = Exerting Force, AF = Applied Force
See page MC-TEC-4 for additional information.

235-U Flanged Base U-Bar

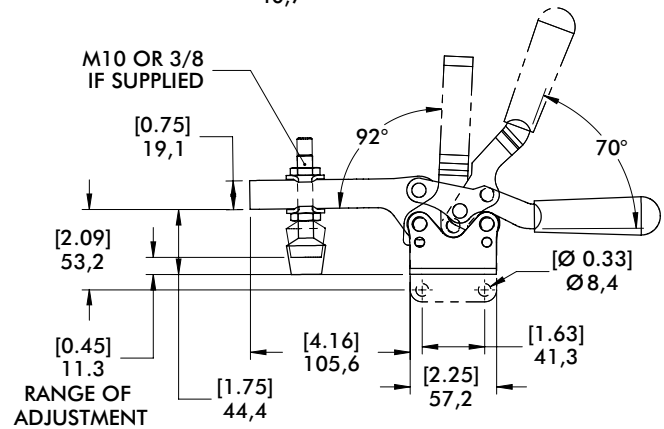
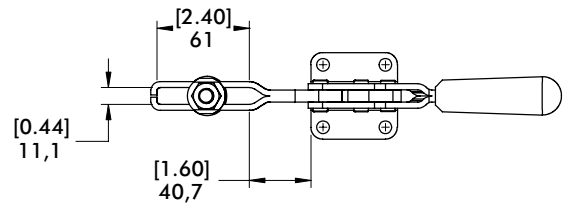
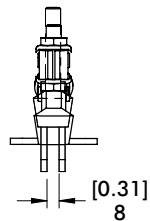

Dimensions | -UR

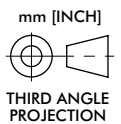
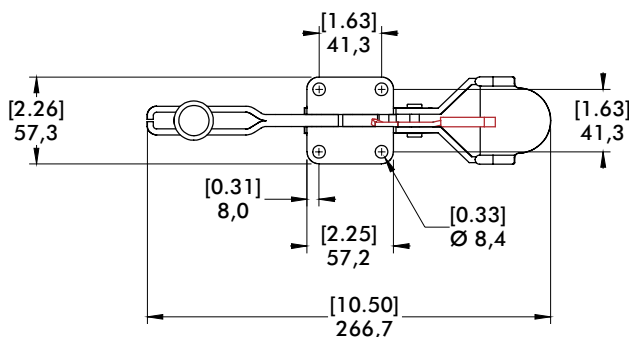
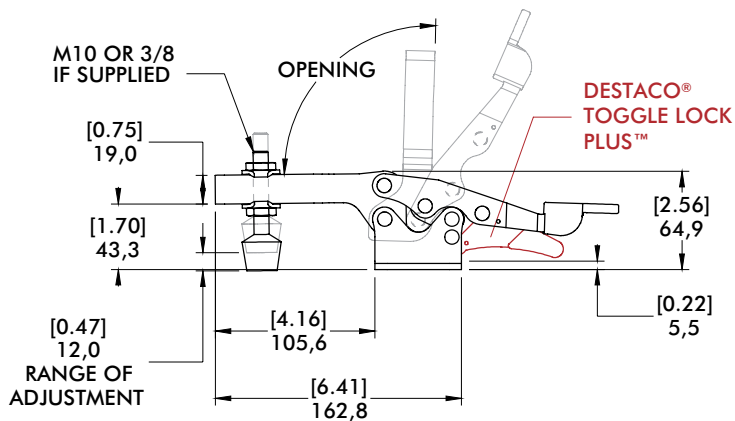
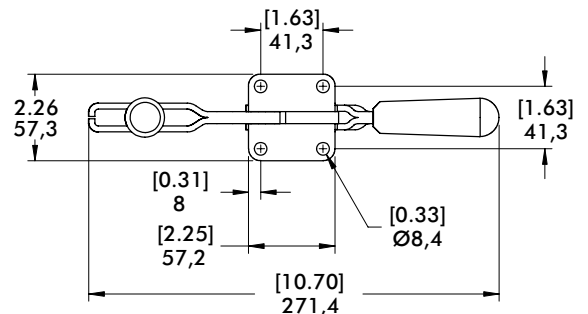
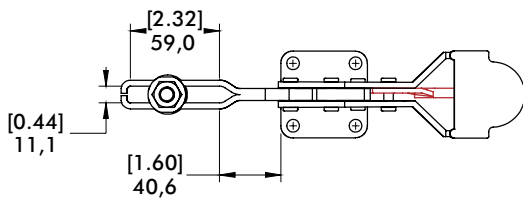

235-UR Flanged Base U-Bar DESTACO® Toggle Lock Plus™



305, 307, 309 SERIES

Horizontal Hold Down Clamps | Product Overview

Features:

- Compact design suitable for use in confined spaces
- Available DESTACO® Toggle Lock Plus™
- Stainless steel models available

Applications:

- Assembly & Test
- Light Machining
- Closures
- Woodworking

Also Available:

See page MC-ACC-1 for accessories

305-U/USS
Flanged Base
U-Bar



-USS Stainless
Steel Model



305-UR/URSS
Flanged Base
U-Bar



-URSS Stainless
Steel Model

DESTACO®
Toggle Lock
Plus™



307-U/USS
Flanged Base
U-Bar



-USS Stainless
Steel Model



307-UR/URSS
Flanged Base
U-Bar



-URSS Stainless
Steel Model

DESTACO®
Toggle Lock
Plus™



309-U/USS
Flanged Base
U-Bar



-USS Stainless
Steel Model



309-UR①
Flanged Base
U-Bar

DESTACO®
Toggle Lock
Plus™



Technical Information

Model	Max. Holding Capacity	Clamp Bar Opening (+10°)	Handle Opening (+10°)	Weight	Accessories (Supplied)	
					Spindle Assembly	Flanged Washers
305-U	670 N [150 lbf]	90°	170°	0,06kg [0.13lb]	305208-M	102111
305-USS	900 N [200 lbf]				201943-M	102911
305-UR	670 N [150 lbf]				305208-M	102111
305-URSS	900 N [200 lbf]				201943-M	102911
307-U	1560 N [350 lbf]	92°	173°	0,24kg [0.54lb]	307208-M	507107
307-USS					207943-M	507907
307-UR					307208-M	507107
307-URSS					207943-M	507907
309-U	3340 N [750 lbf]	90°	168°	1,30kg [0.59lb]	309208	235106
309-USS					237943-M	235906
309-UR①					309208	235106

① This item is available upon request

305, 307, 309 SERIES

Horizontal Hold Down Clamps | Holding Capacities

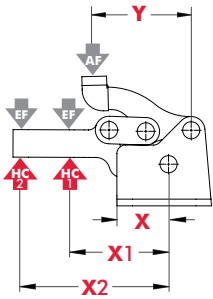

Model	X	X1	X2	Y	±HC1	±HC2	±EF(X1):AF	±EF(X2):AF
305-U/UR	[0.58]	[1.38]	[1.88]	[1.14]	[150lbf.] 670N	[110lbf.] 490N	3:1	2:1
305-USS/ 305-URSS	14,6	35	47,7	29	[200lbf.] 900N	[150lbf.] 670N		
307-U/UR/ USS/URSS	[0.94]	[1.88]	[2.50]	[1.77]	[350lbf.] 1560N	[260lbf.] 1160N	4:1	
309- U/UR/USS	[1.34]	[2.50]	[3.50]	[2.70]	[750lbf.] 3340N	[530lbf.] 2360N		

Dimensions shown "mm [inch]" ± HC = Holding Capacity, EF = Exerting Force, AF = Applied Force
See page MC-TEC-4 for additional information.

Dimensions | -U/-USS/-UR/-URSS

305-U
Flanged Base
U-Bar

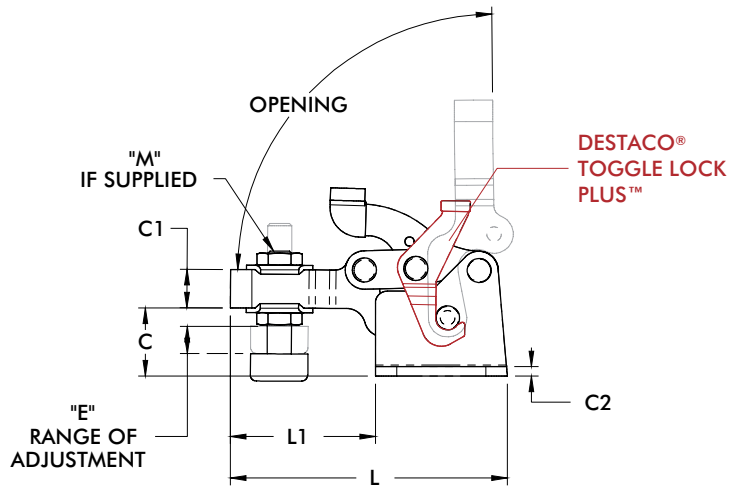
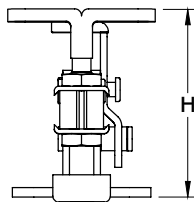
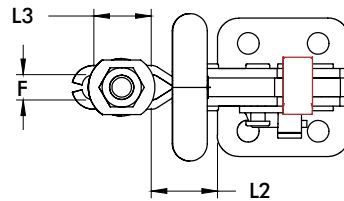

307-UR
Flanged Base
U-Bar
DESTACO®
Toggle Lock
Plus™

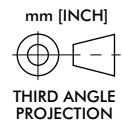
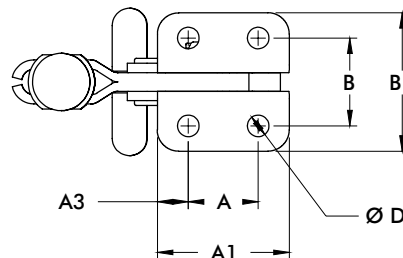

Model	A	A1	A3	B	B1	C	C1	C2	D	E	F	H	L	L1	L2	L3	M
305-U/UR	[0.53] 13,5	[1.035] 26,3	[0.25] 6,4	[0.62] 16,0	[1.02] 25,9	[0.48] 12,2	[0.31] 7,9	[0.08] 2,0	[0.18] 4,6	[0.31] 8	[0.21] 5,3	[1.43] 36,3	[2.21] 56,1	[1.19] 30,2	[0.51] 13,0	[0.50] 12,7	[#10] M5
307-U/UR	[0.91] 23,1	[1.72] 43,7	[0.40] 10,2	[1.14] 29,0	[1.80] 45,7	[0.89] 22,6	[0.50] 12,7	[0.12] 3,0	[0.28] 7,1	[0.37] 9,5	[0.33] 8,4	[2.36] 59,9	[3.61] 91,7	[1.89] 48,0	[0.86] 21,8	[0.75] 19,1	[5/16] M8
309-U/UR	[1.38] 35,1	[2.52] 64,0	[0.58] 14,7	[1.50] 38,1	[2.47] 62,7	[1.31] 33,3	[0.75] 19,1	[0.12] 3,0	[0.33] 8,4	[0.72] 18,5	[0.44] 10,4	[3.53] 89,7	[5.19] 131,8	[2.68] 68,1	[1.28] 32,5	[1.06] 26,9	[3/8-16] M10

206 SERIES

Horizontal Hold Down Clamps | Product Overview

Features:

- All stainless steel construction
- Offers good bar clearance under clamping bar while maintaining low profile

Applications:

- Assembly
- Chemical processing
- Closures
- Light duty clamping

Also Available:

See page MC-ACC-1 for accessories
Accommodates M4 or #8 spindle accessory

206-SS

Flanged Base
Low U-Bar
Stainless Steel



206-HSS

Flanged Base
High U-Bar
Stainless Steel



Technical Information

Model	Max. Holding Capacity	Clamp Bar Opening (+10°)	Handle Opening (+10°)	Weight	Accessories (Supplied)	
					Spindle Assembly	Flanged Washers
206-SS	440 N [100 lbf]	90°	90°	0,03kg [0.07lb]	205943-M	105906
206-HSS						

Model 206-HSS shown securing a platen on a prototyping machine.



206 SERIES

Horizontal Hold Down Clamps | Holding Capacities

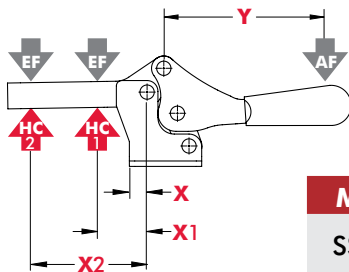

Model	X	X1	X2	Y	±HC1	±HC2	±EF(X1):AF	±EF(X2):AF
SS/HSS	[0.20] 5	[0.43] 11	[1.06] 27	[1.14] 29	[100lbf.] 440N	[50lbf.] 220N	5:1	3:1

Dimensions shown "mm [inch]" ± HC = Holding Capacity, EF = Exerting Force, AF = Applied Force
See page MC-TEC-4 for additional information.

Dimensions | -SS/-HSS

206-SS

Flanged Base
Low U-Bar
Stainless Steel

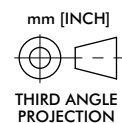
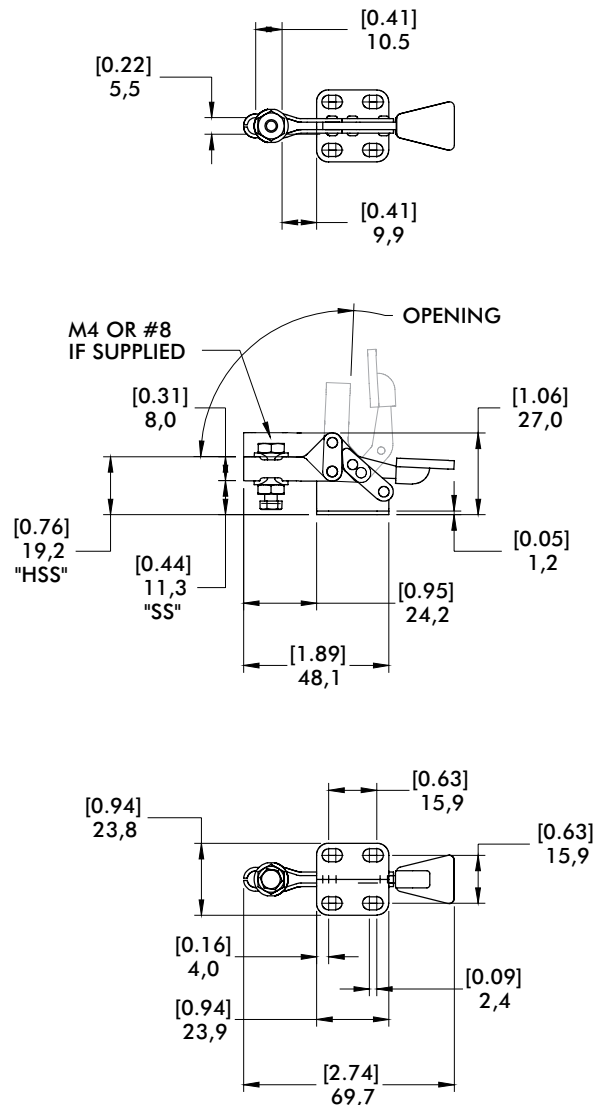

5305, 5310 SERIES

Heavy Duty Horizontal Hold Down Clamps | Product Overview

Features:

- Solid clamping arm may be modified to suit requirements
- Hardened steel pivot pins and bushings provide long life
- Black oxide finish
- DESTACO® Toggle Lock Plus™ versions available†

Applications:

- Welding fixtures
- Assembly fixtures
- Light machining



5305/5310
Flanged Base

5305-**B**/5310-**B**
Solid
Base

5305-**R**/5310-**R**
Flanged Base
DESTACO®
Toggle Lock
Plus™

5305-**BR** ⓘ/5310-**BR** ⓘ
Solid Base
DESTACO®
Toggle Lock
Plus™



Technical Information

Model	Max. Holding Capacity	Clamp Bar Opening (+10°)	Handle Opening (+10°)	Weight
5305	[600lbf.] 2670N	90°	69°	[1.08lbs] 0,49kg
5305-B				[0.82lbs] 0,37kg
5305-R				[1.09lbs] 0,49kg
5305- BR ⓘ				[0.83lbs] 0,37kg
5310	[1300lbf.] 5780N	90°	69°	[2.84lbs] 1,29kg
5310-B				[2.24lbs] 1,02kg
5310-R				[2.87lbs] 1,30kg
5310- BR ⓘ				[2.27lbs] 1,03kg

ⓘ This item is available upon request.

† Toggle Lock Plus™ locks the handle in the closed position only.

5305, 5310 SERIES

Heavy Duty Horizontal Hold Down Clamps | Dimensions

5305/5310
Flanged Base

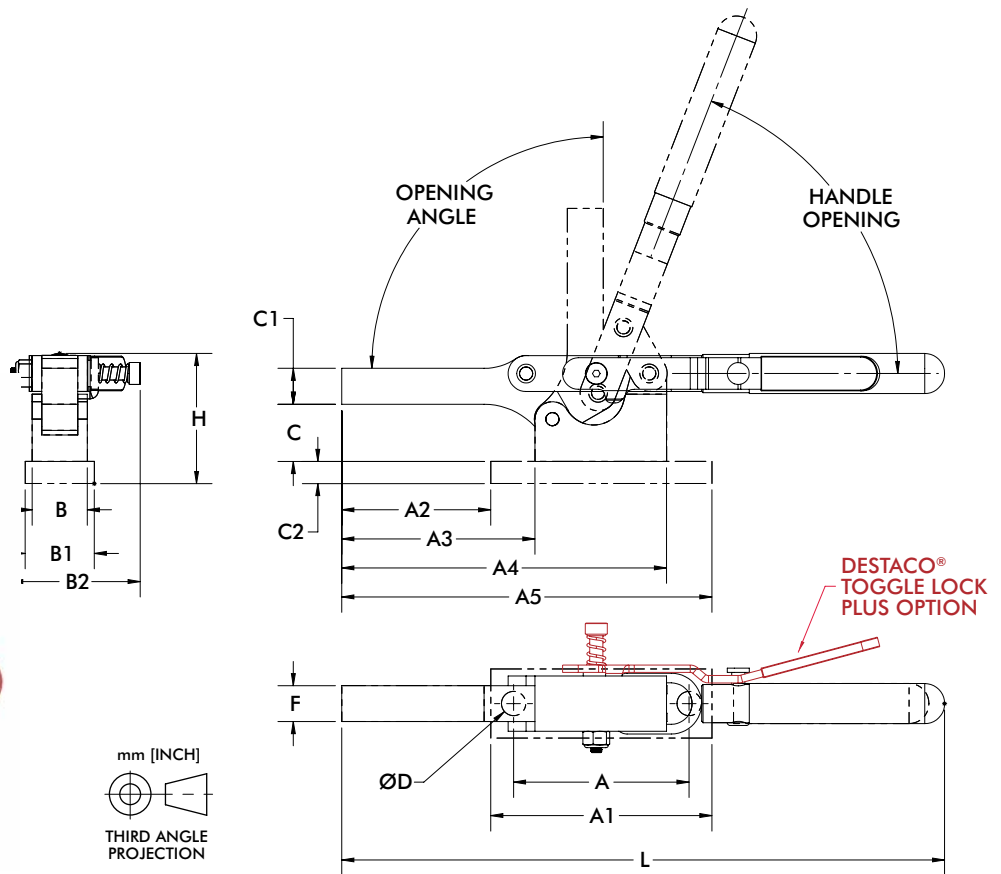

mm [INCH]
THIRD ANGLE
PROJECTION

Model	A	A1	A2	A3	A4	A5	B	B1	B2	C	C1	C2	D	F	H	L
5305	[2.50] 63,5	[3.15] 80,0	[2.12] 53,8	[2.75] 69,9	[4.63] 117,6	[5.27] 133,9	[0.79] 20,1	[0.98] 24,9	--	[0.81] 20,6	[0.51] 13,0	[0.31] 7,9	[0.35] 8,9	[0.51] 13,0	[1.51] 38,4	[8.36] 212,4
5305-R									[1.84] 46,7							
5310	[3.63] 92,2	[4.63] 117,6	[2.63] 66,8	[3.63] 92,2	[6.25] 158,8	[7.25] 184,2	[1.13] 28,7	[1.50] 38,1	--	[1.00] 25,4	[0.75] 19,1	[0.31] 7,9	[0.41] 10,4	[0.79] 20,1	[2.00] 50,8	[11.13] 282,6
5310-R									[2.31] 58,7							[11.02] 279,8

Model	A3	A4	B2	C	C1	F	H	L
5305-B	[2.75] 69,9	[4.63] 117,6	--	[0.81] 20,6	[0.51] 13,0	[0.51] 13,0	[1.51] 38,4	[8.36] 212,4
5305-BR ⓘ			[1.84] 46,7					
5310-B	[3.63] 92,2	[6.25] 158,8	--	[1.00] 25,4	[0.75] 19,1	[0.79] 20,1	[2.35] 59,6	[11.13] 282,6
5310-BR ⓘ			[2.31] 58,7					[11.02] 279,8

ⓘ This item is available upon request