

ELBOW AND STRAIGHT BRACKETS

Round Tooling | Dimensions | Technical Specifications

Nominal (\emptyset) given
See chart on Page 72
for actual (\emptyset) size

DC \emptyset 25mm/1.00" to \emptyset 25mm/1.00" 45° Elbow

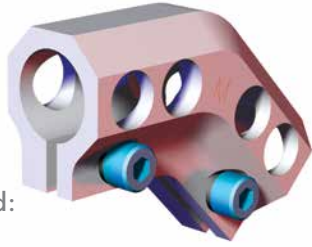

Specifications:
Max. Static Clamp Load:
203 N*m [150 ft-lb]
Material: Aluminum

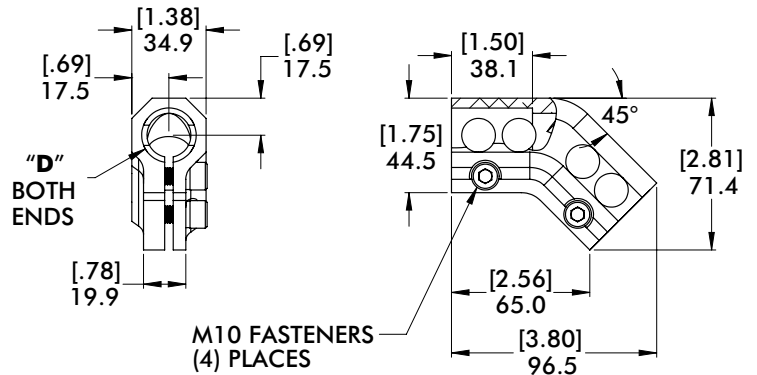

Model Number	(\emptyset) "D"	Weight
CPI-DC-2525M-45	25mm	[.35 lb] .16 kg
CPI-DC-1010-45	1.00"(in)	

DC \emptyset 1.50" to \emptyset 1.50" 45° Elbow

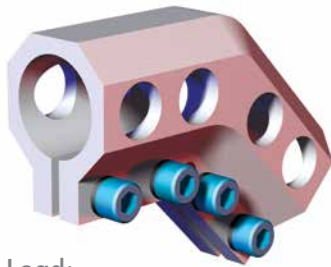

Specifications:
Max. Static Clamp Load:
271 N*m [200 ft-lb]
Material: Aluminum

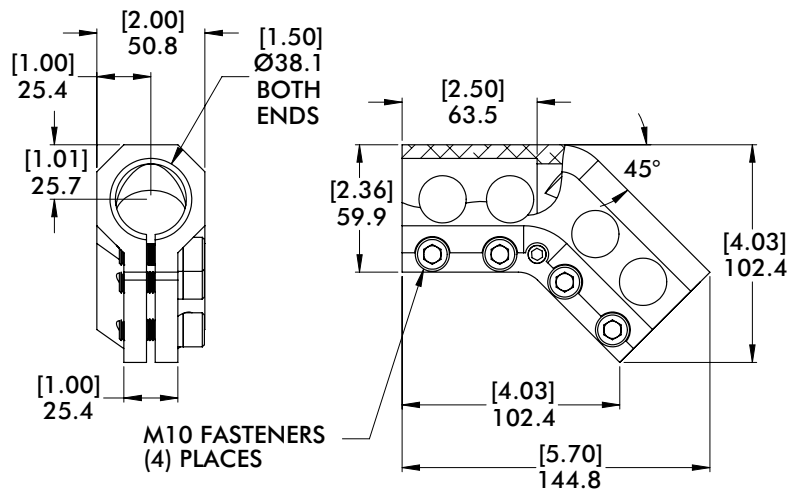

Model Number	Weight
CPI-DC-1515-45	[1.41 lb] .64 kg

DC \emptyset 40mm to \emptyset 40mm 45° Elbow

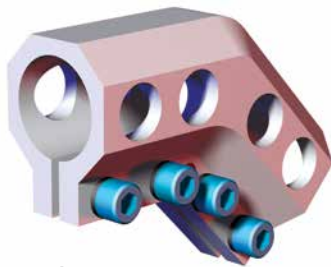

Specifications:
Max. Static Clamp Load:
271 N*m [200 ft-lb]
Material: Aluminum

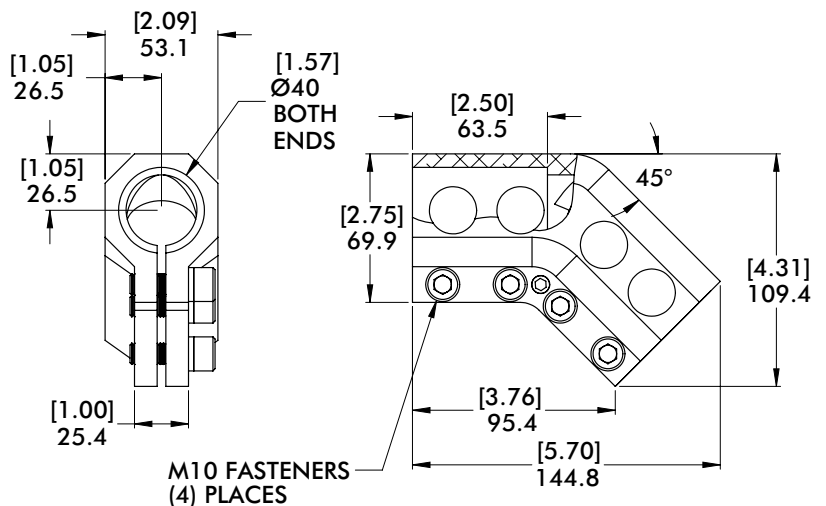

Model Number	Weight
CPI-DC-40-40-45	[1.41 lb] .64 kg

ELBOW AND STRAIGHT BRACKETS

Round Tooling | Dimensions | Technical Specifications

Nominal (\varnothing) given
See chart on Page 72
for actual (\varnothing) size

DC $\varnothing 60\text{mm}$ to $\varnothing 60\text{mm}$ 45° Elbow

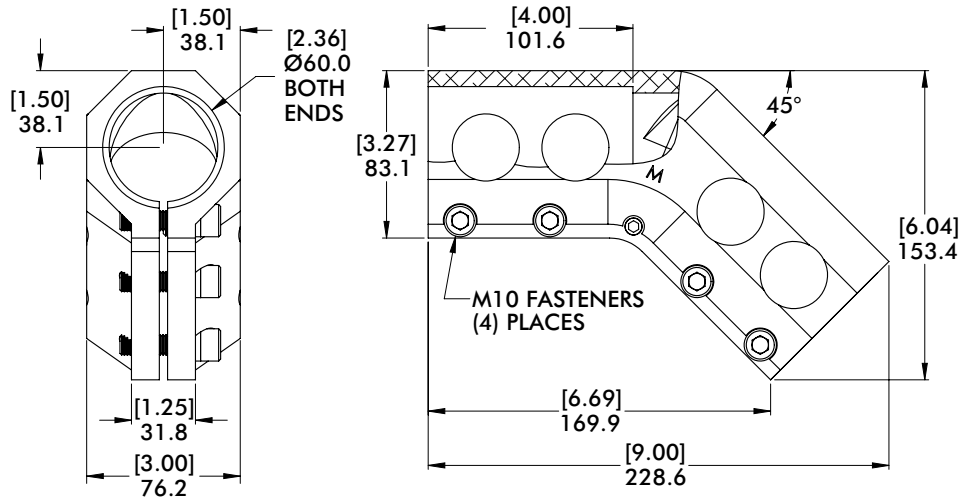
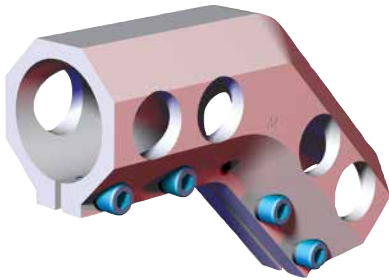

Specifications:
Max. Static Clamp Load:
677N*m [500 ft-lb]
Material: Aluminum

Model Number	Weight
CPI-DC-6060M-45	[2.94 lb] 1.33 kg

DC $\varnothing 2.50''$ to $\varnothing 2.50''$ 45° Elbow

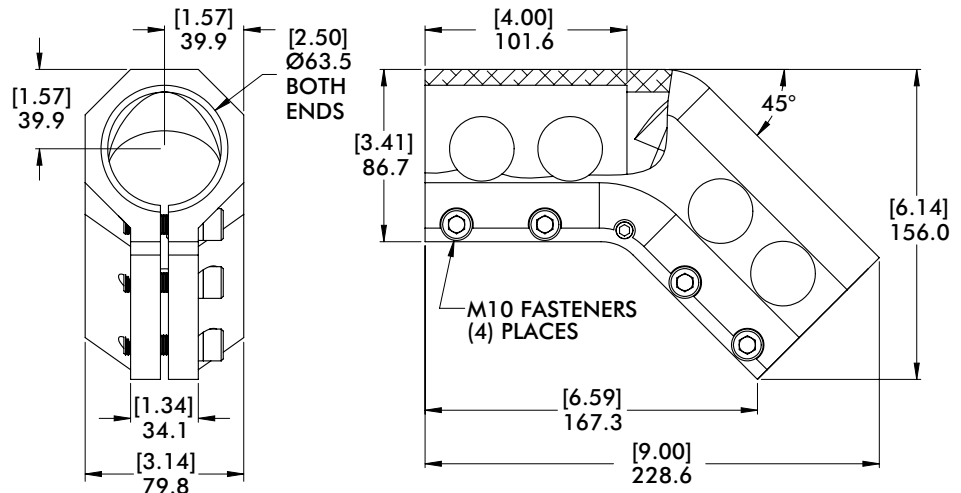
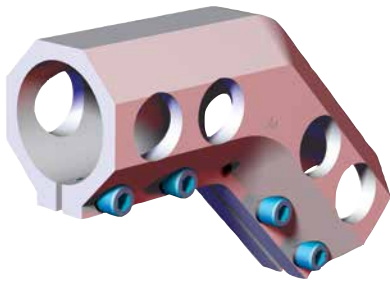

Specifications:
Max. Static Clamp Load:
677 N*m [500 ft-lb]
Material: Aluminum

Model Number	Weight
CPI-DC-2525-45	[3.19 lb] 1.46 kg

DC $\varnothing 25\text{mm}/1.00''$ to $\varnothing 25\text{mm}/1.00''$ Straight with Swivel



Specifications:
Max. Static Clamp Load:
203 N*m [150 ft-lb]
Material: Aluminum

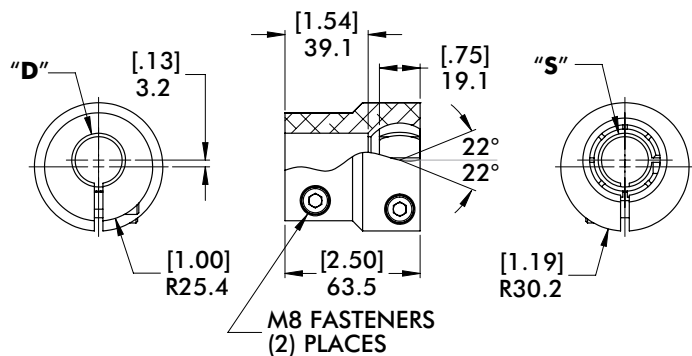

Model Number	(\varnothing) "D"	(\varnothing) "S"	Weight
CPI-DC-2525S-8	25mm	25mm	[.80 lb] .36 kg
CPI-DC-1010S-8	1.00"(in)	1.00"(in)	