

CP, SGM SERIES

Accelerate® Tooling Collection | Lower Nest Tooling Example

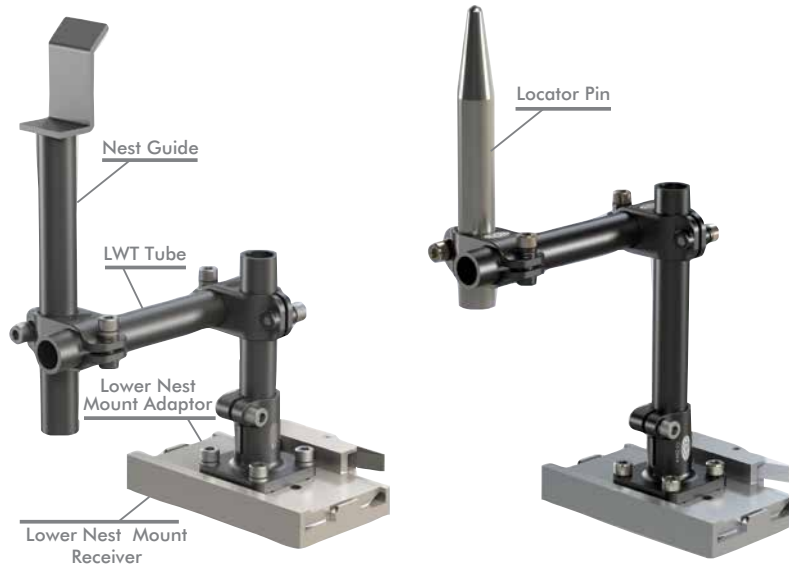

CP Center Pin

Ø20/Ø25, 200mm Length

Model Number	ØD	Weight
CP-20-200	20	427g [0.94 lb]
CP-25-200	25	640g [1.41 lb]

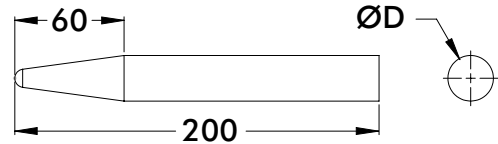

Material: Steel

SGM Mount Receiver



Model Number	Material	Weight
CPI-SGM-TH-USR-AL	Aluminum	670g [1.48 lb]
CPI-SGM-TH-USR	Steel	1730g [3.81 lb]

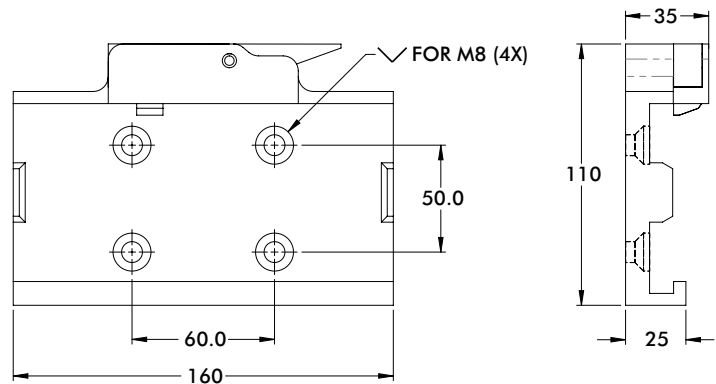

SGM Mount Adaptor



Model Number	Material	Weight
CPI-SGM-TH-USA-AL	Aluminum	287g [0.63 lb]
CPI-SGM-TH-USA	Steel	839g [1.85 lb]

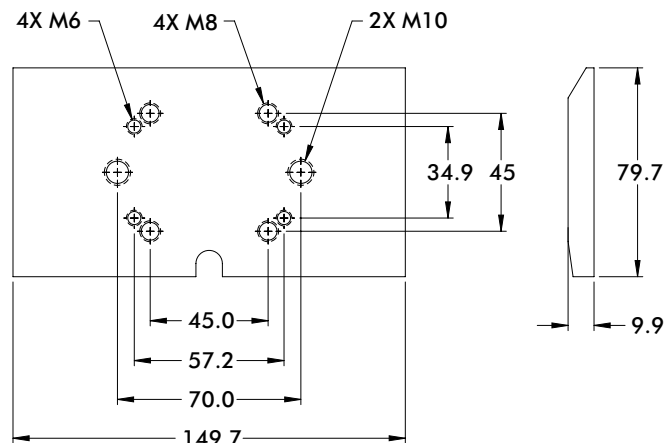

GTS, NPG SERIES

Accelerate® Tooling Collection | Dimensions

GTS Shovel with Welded Post

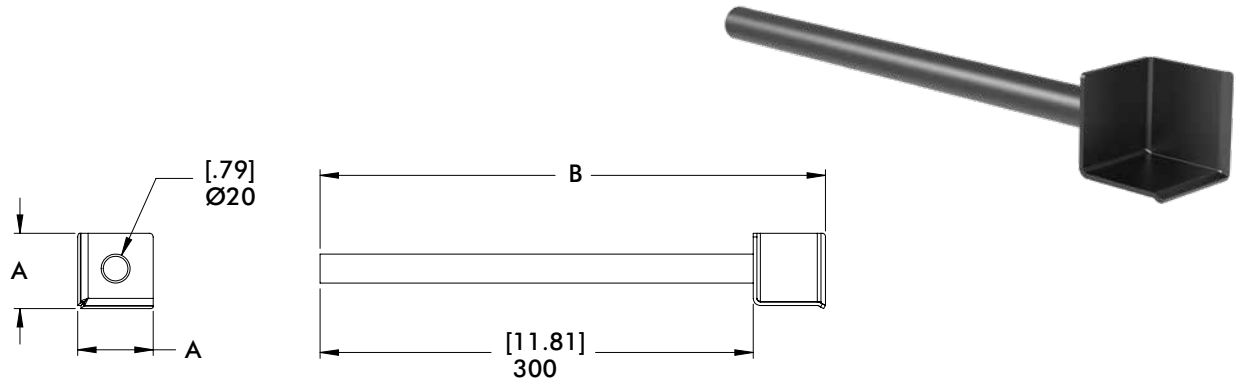

Material: Steel

Model Number	A	B	ØD	Weight
GTS-40-40-40-20M-A	42.2 [1.66]	340 [13.39]	Ø20 [0.79]	290g [0.64 lb]
GTS-40-40-40-30M-A	42.2 [1.66]	340 [13.39]	Ø30 [1.18]	400g [0.88 lb]
GTS-50-50-50-20M-A	52.2 [2.05]	350 [13.78]	Ø20 [0.79]	341g [0.75 lb]
GTS-50-50-50-30M-A	52.2 [2.05]	350 [13.78]	Ø30 [1.18]	451g [0.99 lb]

NPG Nest Guide

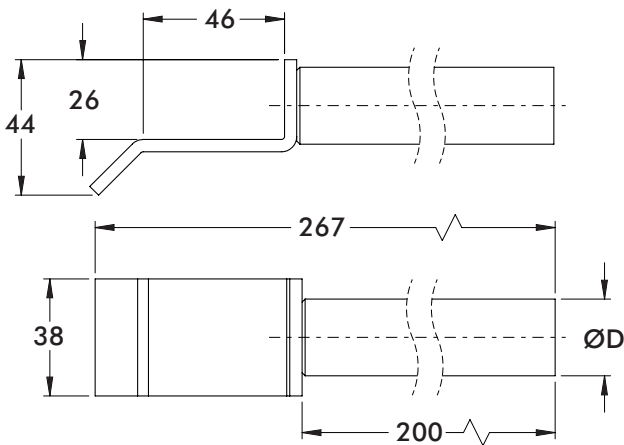

Material: Steel

Ø20/Ø25, 200mm Length

Model Number	ØD	Weight
NPG-25-200	25	432g [0.95 lb]
NPG-20-200	20	365g [0.80 lb]