

ES SERIES

Accelerate® Tooling Collection | Dimensions

ES Single End Extensions

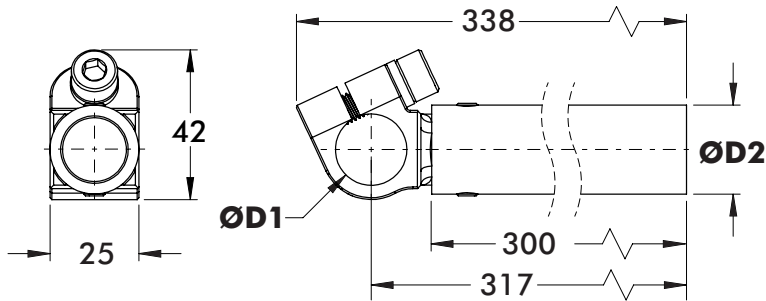

Material: High Strength Aluminum

Model Number	ØD1	ØD2	Weight
ES-20M-25M-300-A	20mm	25mm	250g [0.55 lb]
ES-19M-25M-300-A	19mm	25mm	250g [0.55 lb]
ES-19M-10E-300-A	19mm	1.00 in	269g [0.59 lb]

ES Ø20 to Ø20

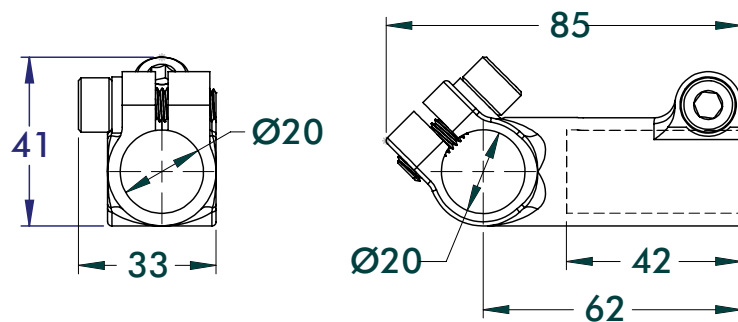

Material: High Strength Aluminum

Model Number	Weight
ES-20M-20M-A	100g [0.22 lb]

Ball Extensions

ES 32mm

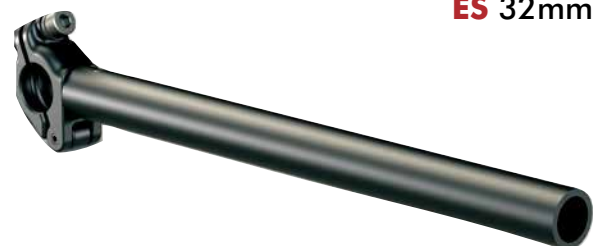
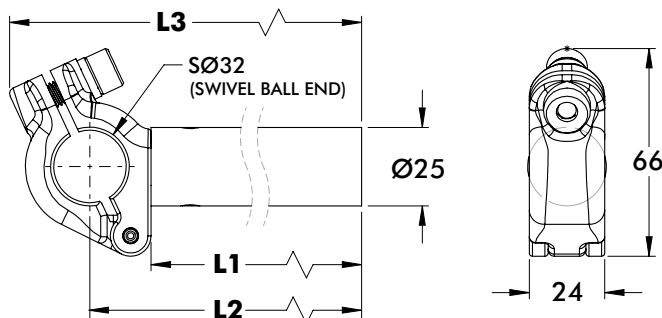

Material: High Strength Aluminum

Model Number	L1	L2	L3	Weight
ES-32B-10E-300-A	300	320	345	277g [0.61 lb]
ES-32B-20M-300-A	300	320	345	225g [0.50 lb]
ES-32B-25M-300-A	300	320	345	262g [0.56 lb]
ES-32B-25M-600-A	600	620	645	437g [0.96 lb]

ES, ESS SERIES

Accelerate® Tooling Collection | Dimensions

ES Ball Extension 28.58mm

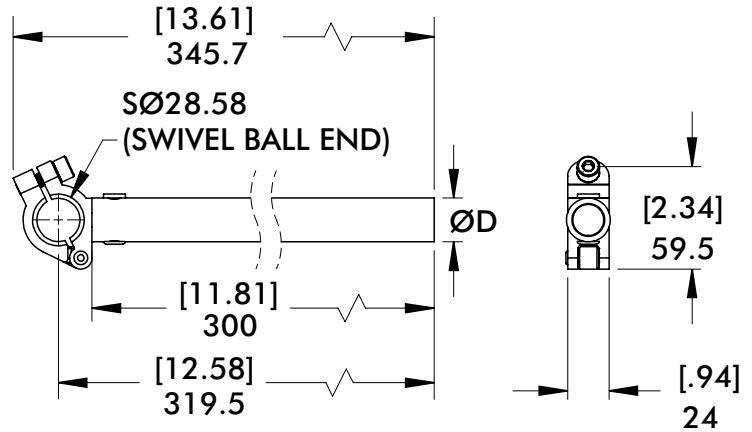

Material: High Strength Aluminum

Model Number	ØD	Weight
ES-B112-25M-300-A	[.98] 25	[0.67 lb] 302g
ES-B112-10E-300-A	[1.00] 25.4	[0.67 lb] 302g

ESS Ball Extension 32mm

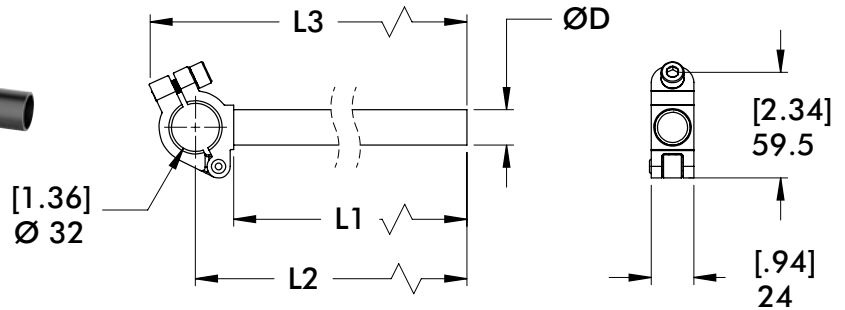

Material: Steel

Model Number	ØD	L1	L2	L3	Weight
ESS-32B-20M-300-S	20 [.79]	298 [11.73]	319.5 [12.58]	345 [13.58]	410g [0.90 lb]
ESS-32B-20M-600-S	20 [.79]	598 [23.54]	598 [23.54]	645 [25.39]	674g [1.48 lb]
ESS-32B-30M-300-S	30 [1.18]	298 [11.73]	319.5 [12.58]	345 [13.58]	516g [1.14 lb]
ESS-32B-30M-600-S	30 [1.18]	598 [23.54]	598 [23.54]	645 [25.39]	830g [1.83 lb]

ESS-90 Ball Extension 32mm

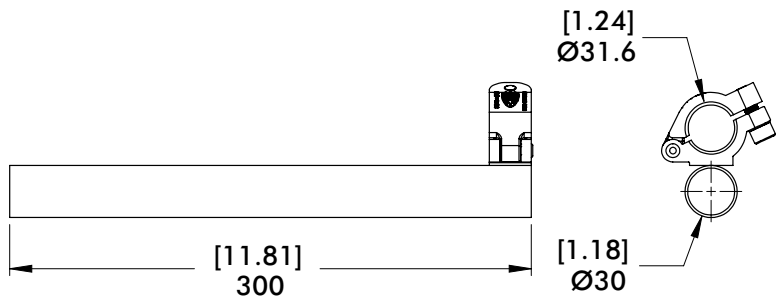

Model Number	ØD	Weight
ESS-32B-30M-90-300-S	30 [1.18]	518.4g [1.14 lb]