

SINGLE END EXTENSIONS

Round Tooling | Dimensions | Technical Specifications

ES Rod End and Mounting Extensions

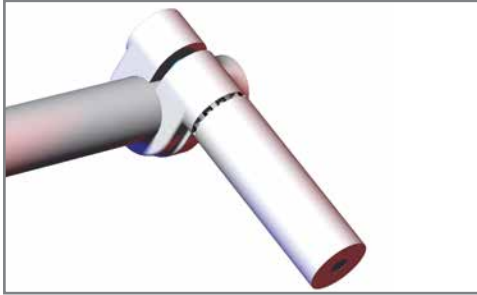

Features:

- Mounts to round tube for extended mounting options
- Provides 360° of rotational adjustments along a single axis

Specifications:

Maximum Clamp Load:
200 ft-lb [271 Nm]
Material:
Body:
Cast Aluminum
Extension:
Machined Aluminum

ES Ø25mm/1.00" Rod End Extensions

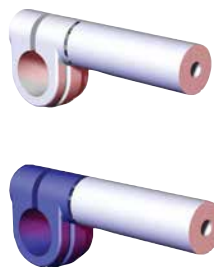

"L" = Specify Length from Below

English Lengths:

From **03**(3.00") to **28**(28.00")
in 1.00" Increments

Order Example

CPI-ES10-100-06 (6.00" Length)

Metric Lengths:

From **50**(50mm) to **400**(400mm)
in 50mm Increments

Order Example

CPI-ES25-25-250 (250mm Length)

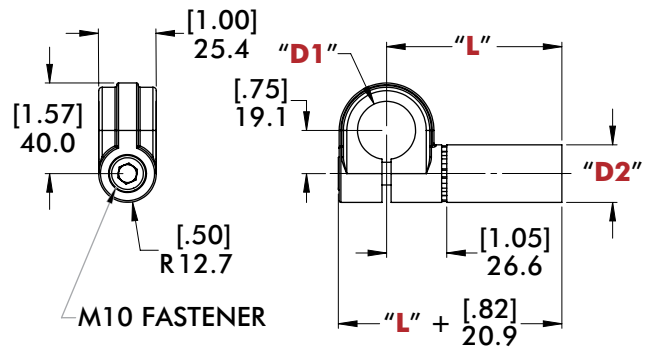

Model Number	(Ø)"D1"	(Ø)"D2"	Weight (Base + Additional Increments)	FINISH
CPI-ES10-100-"L"	1.00"(in)	1.00"(in)	Base Length "L" 03 = 0.19 kg [0.42 lb] Add .031 kg [.068 lb] per additional increment	SILVER
CPI-ES25-25-"L"	25mm	25mm	Base Length "L" 100 = 0.22 kg [0.49 lb] Add .061 kg [.134 lb] per additional increment	BLUE

ES Ø40mm/1.50" Rod End Extensions

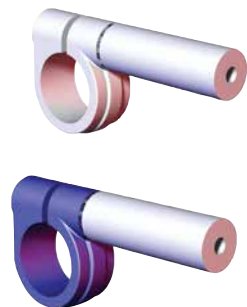

"L" = Specify Length from Below

English Lengths:

From **03**(3.00") to **28**(28.00")
in 1.00" Increments

Order Example

CPI-ES10-150-06 (6.00" Length)

Metric Lengths:

From **50**(50mm) to **400**(400mm)
in 50mm Increments

Order Example

CPI-ES25-40-250 (250mm Length)

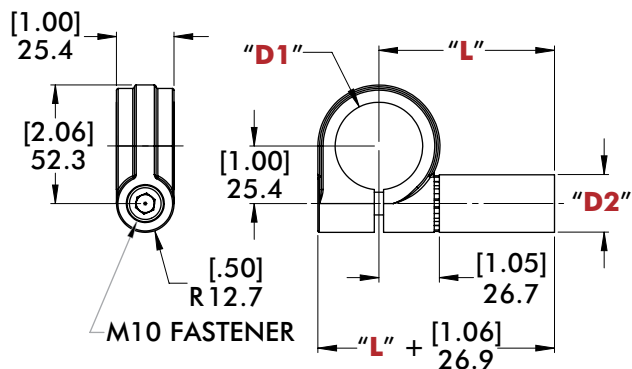

Model Number	(Ø)"D1"	(Ø)"D2"	Weight (Base + Additional Increments)	FINISH
CPI-ES10-150-"L"	1.50"(in)	1.00"(in)	Base Length "L" 03 = 0.21 kg [0.46 lb] Add .031 kg [.068 lb] per additional increment	SILVER
CPI-ES25-40-"L"	40mm	25mm	Base Length "L" 100 = 0.23 kg [0.51 lb] Add .061 kg [.134 lb] per additional increment	BLUE

SINGLE END EXTENSIONS

Round Tooling | Dimensions | Technical Specifications

Nominal (Ø) given
See chart on Page 72
for actual (Ø) size



Mounting End
Extensions
CPI-ES10-075-06
(Shown Above)

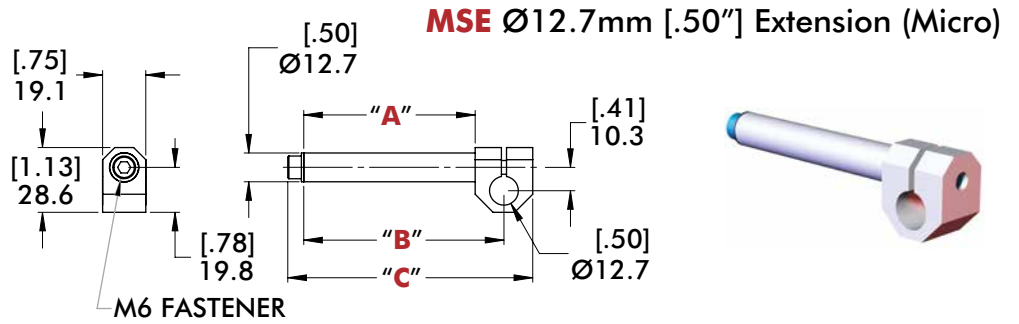

Model Number	"A"	"B"	"C"	Weight
CPI-MSE-50-50-03	[2.98] 75.6	[3.48] 88.3	[4.25] 108.1	[0.14 lb] 0.06 kg
CPI-MSE-50-50-06	[5.73] 145.5	[6.23] 158.2	[7.00] 177.9	[0.20 lb] 0.09 kg

ES Ø25mm/1.00" Extension for Ø19.1mm [0.75"] Apple Core

"L" = Specify Length from Below

English Lengths:
From 03(3.00") to 28(28.00")
in 1.00" Increments

Order Example
CPI-ES10-075-06 (6.00" Length)

Metric Lengths:
From 50(50mm) to 400(400mm)
in 50mm Increments

Order Example
CPI-ES25-19-250 (250mm Length)

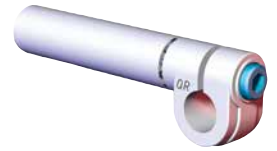
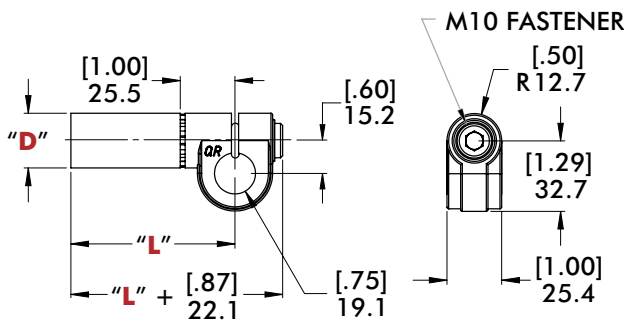

Model Number	(Ø)"D"	Weight (Base + Additional Increments)	FINISH
CPI-ES10-075-"L"	1.00"(in)	Base Length "L" 03 = 0.17 kg [0.38 lb] Add .031 kg [0.068 lb] per additional increment	SILVER
CPI-ES25-19-"L"	25mm	Base Length "L" 100 = 0.22 kg [0.49 lb] Add .031 kg [0.068 lb] per additional increment	BLUE

ESxx Ø25mm/1.00" Extension for Ø28.6mm [1.125"] Spherical Swivel Ball

"L" = Specify Length from Below

English Lengths:
From 03(3.00") to 18(18.00")
in 1.00" Increments

Order Example
CPI-ES10-B112-06 (6.00" Length)

Metric Lengths
From 50 (50mm) to 400(400mm)
in 25mm Increments

Order Example
CPI-ES25-B112-75 (75mm Length)

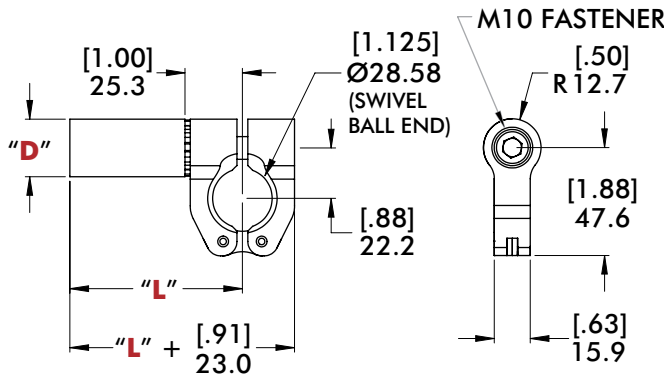

Model Number	(Ø)"D"	Weight (Base + Additional Increments)	FINISH
CPI-ES10-B112-"L"	1.00"(in)	Base Length "L" 03 = 0.23 kg [0.51 lb] Add .031 kg [0.068 lb] per additional increment	SILVER
CPI-ES25-B112-"L"	25mm	Base Length "L" 100 = 0.23 kg [0.51 lb] Add .029 kg [0.064 lb] per additional increment	BLUE