

T110 SERIES

OEM Linear Slide | Features and Benefits | How To Order

Features:

- Cost effective precision slide tables
- Designed for OEM machine builders
- 44 models with various stroke lengths
- Bore sizes: 6, 8, 12, 16, 20, 25mm
- Smooth operation with cross roller bearings
- Stroke adjust with shock absorbers or rubber stops
- High payload capacity
- Drop-in replacement



How To Order

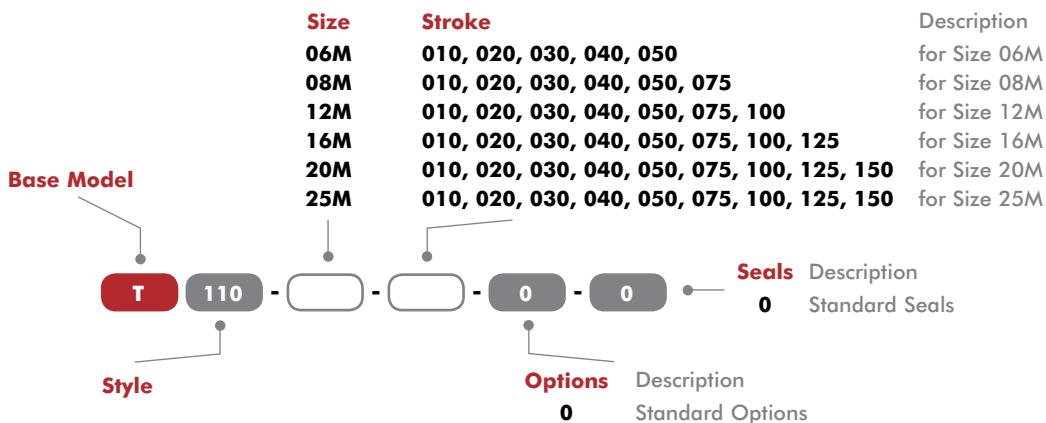

Accessories

T110 Common Accessories	Model Numbers	Part Number	Qty/Unit
Sensor, NPN magneto resistive type, 4mm Barrel	All Models	OHSN-021	1-2
Sensor, PNP magneto resistive type, 4mm Barrel	All Models	OHSP-021	1-2
Cable straight, quick disconnect, socket, 3 conductor, 2M length	All Models	CABL-010	1-2

*Sensor and cable sold separately.



Cable Straight, Quick Disconnect, Socket, 3 Conductor, 2M Length



Long Barrel 4mm Straight Sensor

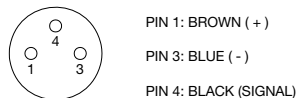
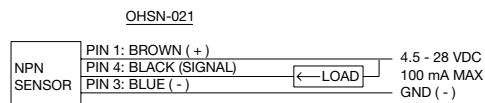
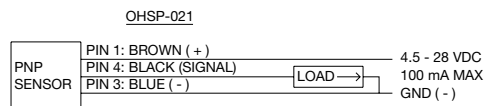

T110 SERIES

OEM Linear Slide | Accessories

T110-06M	Part Number	Qty/Unit
M5 Adjustable Flow Control, 6mm OD Tube	VLVF-008	1-2
Stop Kit, Adjustable, Extend	OSAK-088	1
Stop Kit, Adjustable, Retract	OSAK-094	1
Seal Repair Kit (includes: Piston Seal, Retainer C-clip, Rod Seal, O-ring, Bumper)	SLKT-248	1

T110-08M	Part Number	Qty/Unit
M5 Adjustable Flow Control, 6mm OD Tube	VLVF-008	1-2
Stop Kit, Adjustable, Extend	OSAK-089	1
Stop Kit, Adjustable, Retract	OSAK-095	1
Shock Absorber Kit, Extend	OSAK-123	1
Shock Absorber Kit, Retract	OSAK-128	1
Spare Shock Absorber	SHOK-057	1
Seal Repair Kit (includes: Piston Seal, Retainer C-clip, Rod Seal, O-ring, Bumper)	SLKT-249	1

T110-12M	Part Number	Qty/Unit
M5 Adjustable Flow Control, 6mm OD Tube	VLVF-008	1-2
Stop Kit, Adjustable, Extend	OSAK-090	1
Stop Kit, Adjustable, Retract	OSAK-096	1
Shock Absorber Kit, Extend	OSAK-124	1
Shock Absorber Kit, Retract	OSAK-129	1
Spare Shock Absorber	SHOK-057	1
Seal Repair Kit (includes: Piston Seal, Retainer C-clip, Rod Seal, O-ring, Bumper)	SLKT-250	1

T110-16M	Part Number	Qty/Unit
M5 Adjustable Flow Control, 6mm OD Tube	VLVF-008	1-2
Stop Kit, Adjustable, Extend	OSAK-091	1
Stop Kit, Adjustable, Retract	OSAK-097	1
Shock Absorber Kit, Extend	OSAK-125	1
Shock Absorber Kit, Retract	OSAK-130	1
Spare Shock Absorber	SHOK-059	1
Seal Repair Kit (includes: Piston Seal, Retainer C-clip, Rod Seal, O-ring, Bumper)	SLKT-251	1

T110-20M	Part Number	Qty/Unit
G1/8 Adjustable Flow Control, 6mm OD Tube	VLVF-005	1-2
Stop Kit, Adjustable, Extend	OSAK-092	1
Stop Kit, Adjustable, Retract	OSAK-098	1
Shock Absorber Kit, Extend	OSAK-126	1
Shock Absorber Kit, Retract	OSAK-131	1
Spare Shock Absorber	SHOK-060	1
Seal Repair Kit (includes: Piston Seal, Retainer C-clip, Rod Seal, O-ring, Bumper)	SLKT-252	1

T110-25M	Part Number	Qty/Unit
G1/8 Adjustable Flow Control, 6mm OD Tube	VLVF-005	1-2
Stop Kit, Adjustable, Extend	OSAK-093	1
Stop Kit, Adjustable, Retract	OSAK-099	1
Shock Absorber Kit, Extend	OSAK-127	1
Shock Absorber Kit, Retract	OSAK-132	1
Spare Shock Absorber	SHOK-061	1
Seal Repair Kit (includes: Piston Seal, Retainer C-clip, Rod Seal, O-ring, Bumper)	SLKT-253	1

T110 SERIES

OEM Linear Slide | Quick Installation Kits

Commissioning Kits for Easy Ordering

- Includes just what you need for easy installation
- One quick installation kit required per slide
- Fast, simple convenient ordering



T110-06M	Includes	Part Number	Qty/Kit
Sensors, PNP Magneto Resistive Type, 4mm Barrel	OHSP-021	T110-QKST-101	2
Quick Disconnect 2 Meter Cable Length	CABL-010		2
Adjustable Flow Control, M5, 6mm OD Tube	VLVF-008		2
T110-08M	Includes	Part Number	Qty/Kit
Sensors, PNP Magneto Resistive Type, 4mm Barrel	OHSP-021	T110-QKST-102	2
Quick Disconnect 2 Meter Cable Length	CABL-010		2
Adjustable Flow Control, M5, 6mm OD Tube	VLVF-008		2
Shock Absorber Kit, Extend	OSAK-123		1
Shock Absorber Kit, Retract	OSAK-128		1
T110-12M	Includes	Part Number	Qty/Kit
Sensors, PNP Magneto Resistive Type, 4mm Barrel	OHSP-021	T110-QKST-103	2
Quick Disconnect 2 Meter Cable Length	CABL-010		2
Adjustable Flow Control, M5, 6mm OD Tube	VLVF-008		2
Shock Absorber Kit, Extend	OSAK-124		1
Shock Absorber Kit, Retract	OSAK-129		1
T110-16M	Includes	Part Number	Qty/Kit
Sensors, PNP Magneto Resistive Type, 4mm Barrel	OHSP-021	T110-QKST-104	2
Quick Disconnect 2 Meter Cable Length	CABL-010		2
Adjustable Flow Control, M5, 6mm OD Tube	VLVF-008		2
Shock Absorber Kit, Extend	OSAK-125		1
Shock Absorber Kit, Retract	OSAK-130		1
T110-20M	Includes	Part Number	Qty/Kit
Sensors, PNP Magneto Resistive Type, 4mm Barrel	OHSP-021	T110-QKST-105	2
Quick Disconnect 2 Meter Cable Length	CABL-010		2
Adjustable Flow Control, G1/8, 6mm OD Tube	VLVF-005		2
Shock Absorber Kit, Extend	OSAK-126		1
Shock Absorber Kit, Retract	OSAK-131		1
T110-25M	Includes	Part Number	Qty/Kit
Sensors, PNP Magneto Resistive Type, 4mm Barrel	OHSP-021	T110-QKST-106	2
Quick Disconnect 2 Meter Cable Length	CABL-010		2
Adjustable Flow Control, G1/8, 6mm OD Tube	VLVF-005		2
Shock Absorber Kit, Extend	OSAK-127		1
Shock Absorber Kit, Retract	OSAK-132		1

T110 SERIES

OEM Linear Slide | Accessories Dimensions

Shock Absorbers

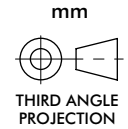
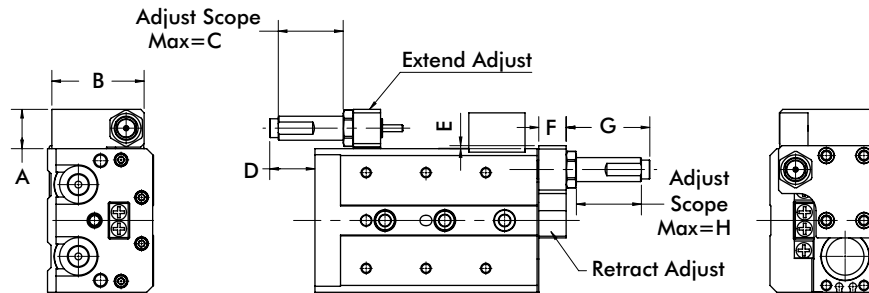

For Model No.	A	B	C	D	E	F	G	H
T110-08M	13	22.5	18.5	18.5	0.1	8.5	28.5	19.5
T110-12M	14.5	29.5	17.5	15	0.5	11	26	17
T110-16M	16.5	37.7	25	18.5	1.5	12	35	26
T110-20M	21	46.5	23.5	14.5	0.5	15	34	25
T110-25M	23	56.5	37.5	26	1.8	16	49	38

Stop Kits

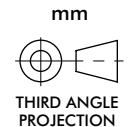
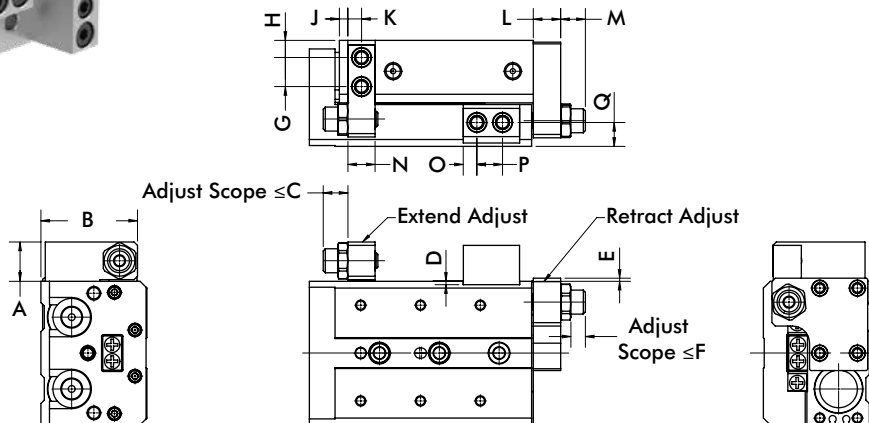

For Model No.	A	B	C	D	E	F	G	H	J	K	L	M	N	O	P	Q
T110-06M	10	20	5	0.5	--	10	5.5	3	2	3.5	7	13.5	7	3	6.5	5
T110-08M	13	22.5	7	0.5	--	7.5	6.5	4	2	4.5	8.5	11	8.5	4	7	5.5
T110-12M	14.5	30	6	1	1.4	5	8	5.5	2	5.5	11	9.5	11	6	8.5	7
T110-16M	16.5	37.5	6	--	1.5	6.5	11	6.5	3	6	12	11	12	6.5	10	7.5
T110-20M	21	46.5	6.5	1.5	1	7.5	13.5	8	3	7.5	15	12	15	6.5	12	12
T110-25M	23	56.5	8.5	2	1.8	8.5	17	10	5	8	16	15	16	8	15	14

T110-06M

OEM Linear Slide | Dimensions and Technical Specifications

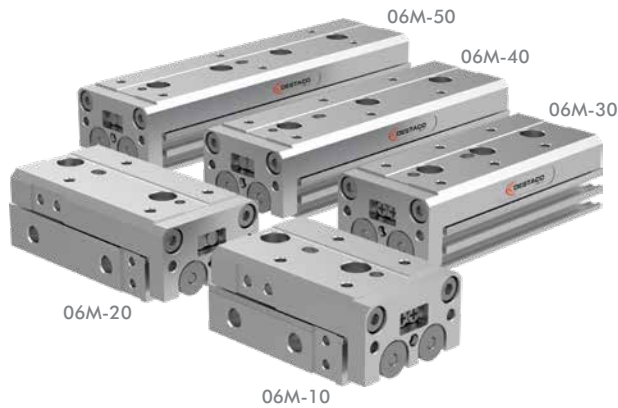

Specifications	Units	06M
Thrust Force at 7 bar [100 psi]	Retract	29 [6.51]
	Extend	40 [9.0]
Pressure Range	bar [psi]	1.5-7 [22-100]
Cylinder Bore Diameter [x2]	mm [in]	6 [0.23]
Speed Range	mm/sec [in/sec]	50-500 [2-20]
End Stop Repeatability, Basic Unit	mm [in]	±0.5 [±0.02]
End Stop Repeatability, Stop Kit	mm [in]	±0.2 [±0.01]
End Stop Repeatability, Shock Kit	mm [in]	±0.02 [±0.001]
Valve Required to Actuate		4 Way 2 Position

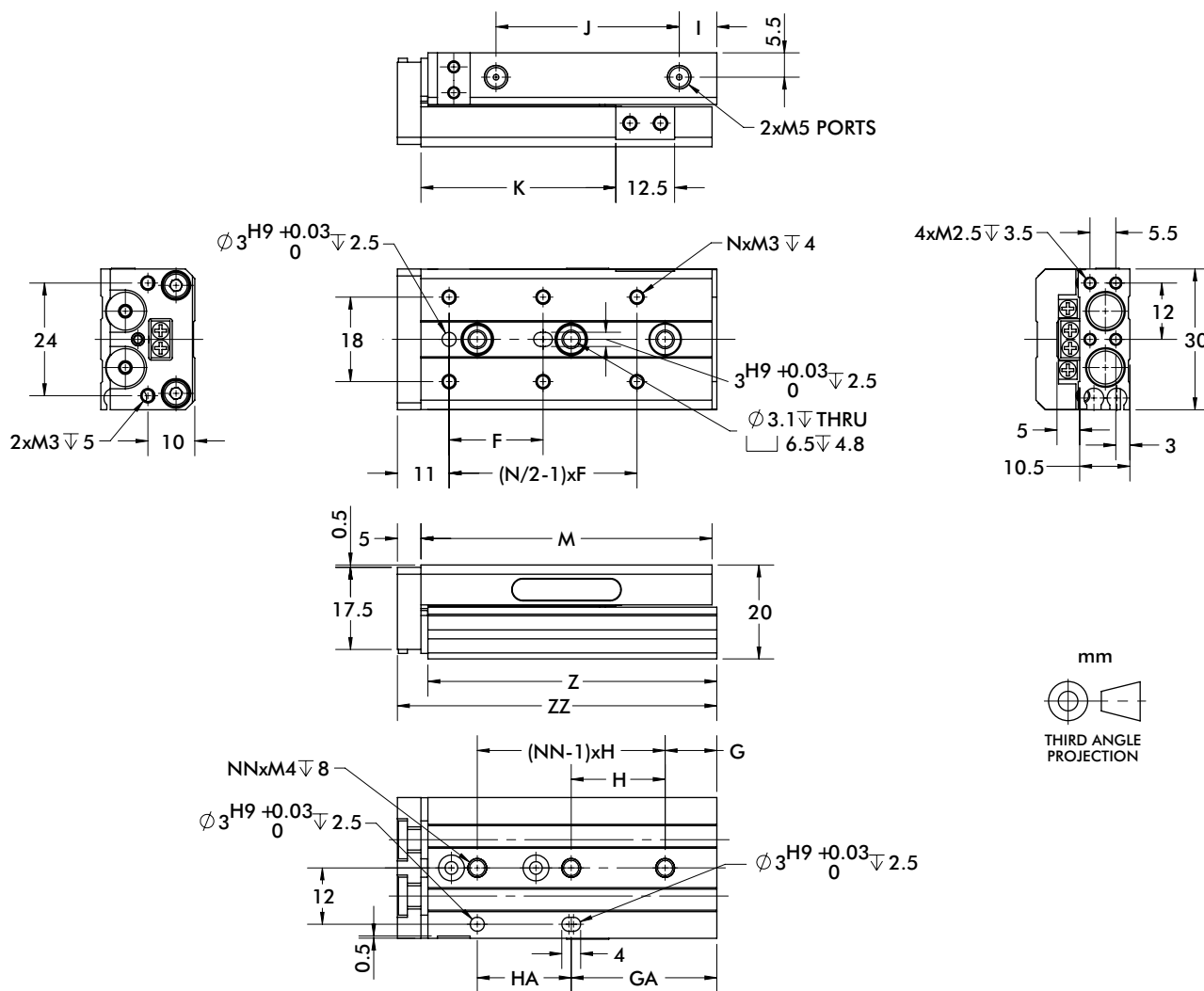

Stroke \ Item	F	N	G	H	NN	GA	HA	I	J	K	M	Z	ZZ
10	20	4	6	25	2	11	20	8	19	21.5	42	41.5	48
20	30	4	6	35	2	21	20	9	28	31.5	52	51.5	58
30	20	6	11	20	3	31	20	8	39	41.5	62	61.5	68
40	28	6	13	30	3	43	30	18	51	51.5	84	83.5	90
50	38	6	17	24	4	41	48	24	61	61.5	100	99.5	106

Specifications	Units	06M-10	06M-20	06M-30	06M-40	06M-50
Stroke	mm (in)	10 [0.39]	20 [0.79]	30 [1.18]	40 [1.57]	50 [1.97]
Weight	kg (lb)	0.08 [0.178]	0.1 [0.222]	0.12 [0.256]	0.16 [0.344]	0.18 [0.4]
Displacement	cc (cu-in)	0.57 [0.035]	1.13 [0.069]	1.70 [0.104]	2.26 [0.138]	2.83 [0.173]
Max. Applied Load	N (lbf)	5 [1.124]	5 [1.124]	5 [1.124]	5 [1.124]	5 [1.124]

Deflection

(Note: Moment calculations located on page 31)

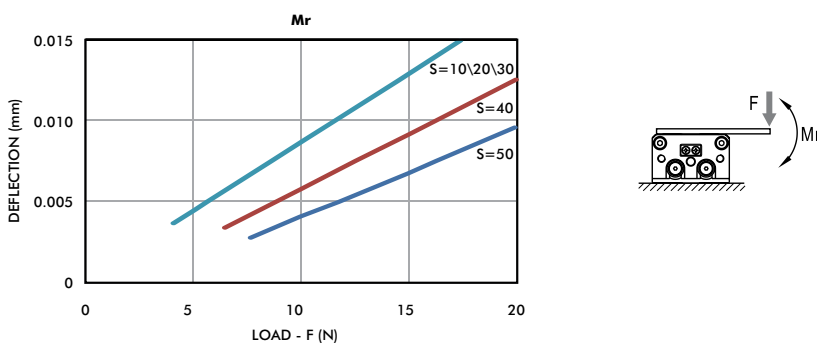
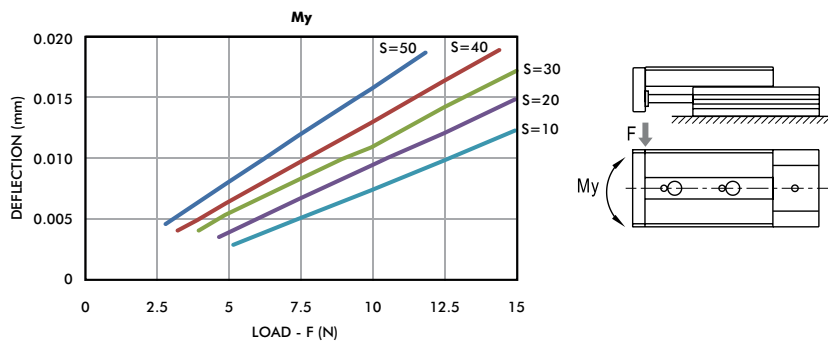
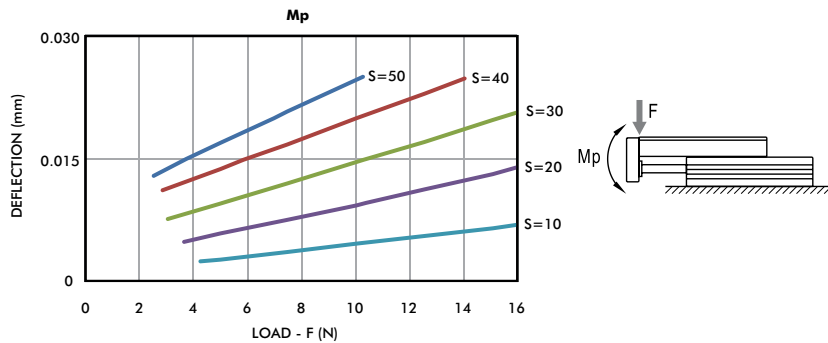

Payload vs. Velocity

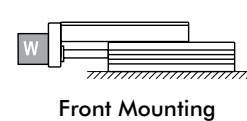
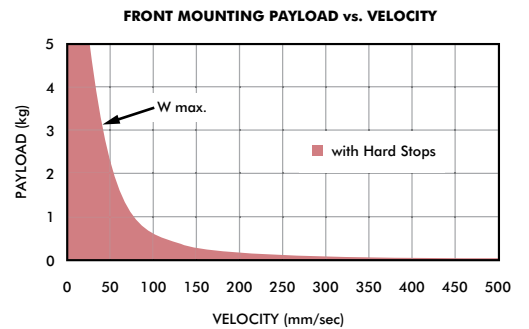
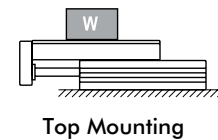
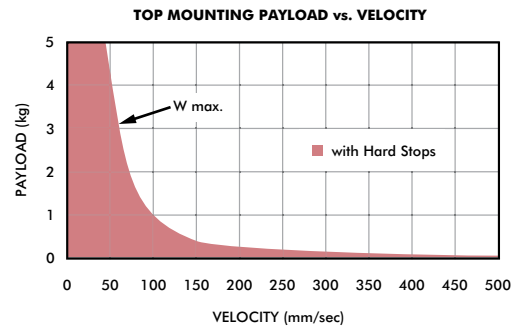

T110-08M

OEM Linear Slide | Dimensions and Technical Specifications



Specifications	Units	08M
Thrust Force at 7 bar [100 psi]	Retract	53 [11.9]
	Extend	71 [16.0]
Pressure Range	bar [psi]	1.5-7 [22-100]
Cylinder Bore Diameter [x2]	mm [in]	8 [0.31]
Speed Range	mm/sec [in/sec]	50-500 [2-20]
End Stop Repeatability, Basic Unit	mm [in]	±0.5 [±0.02]
End Stop Repeatability, Stop Kit	mm [in]	±0.2 [±0.01]
End Stop Repeatability, Shock Kit	mm [in]	±0.02 [±0.001]
Valve Required to Actuate		4 Way 2 Position

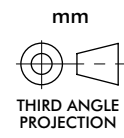
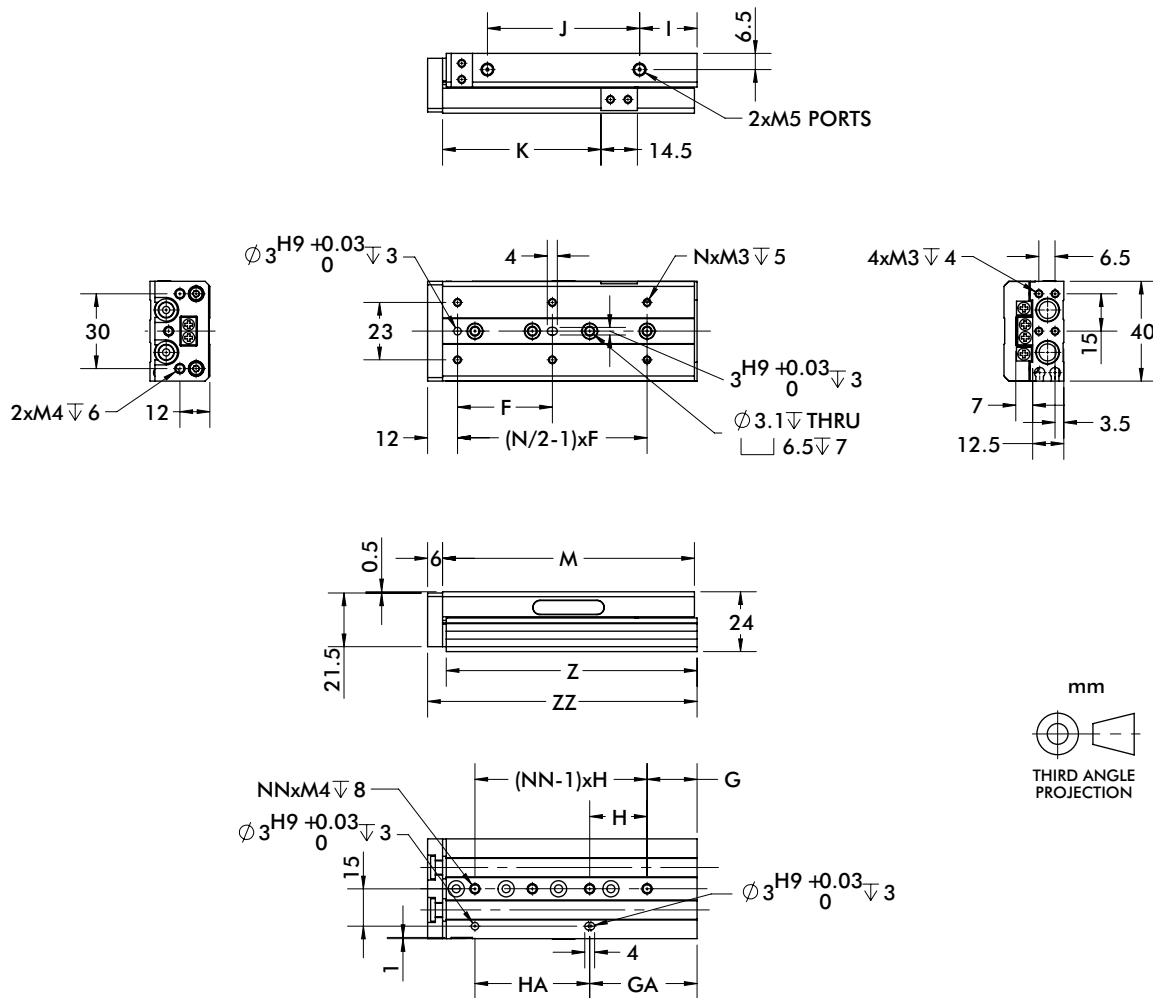

Stroke\Item	F	N	G	H	NN	GA	HA	I	J	K	M	Z	ZZ
10	25	4	9	28	2	17	20	12	20	23.5	49	48.5	56
20	25	4	12	30	2	12	30	7	30	33.5	54	53.5	61
30	40	4	13	20	3	33	20	7	41	43.5	65	64.5	72
40	50	4	15	28	3	43	28	10	56	53.5	83	82.5	90
50	38	6	20	23	4	43	46	23	61	63.5	101	100.5	108
75	50	6	27	28	5	83	56	40	94	88.5	151	150.5	158

Specifications	Units	08M-10	08M-20	08M-30
Stroke	mm (in)	10 [0.39]	20 [0.79]	30 [1.18]
Weight	kg (lb)	0.15 [0.333]	0.16 [0.356]	0.19 [0.422]
Displacement	cc (cu-in)	1.01 [0.061]	2.01 [0.123]	3.02 [0.184]
Max. Applied Load	N (lbf)	10 [2.248]	10 [2.248]	10 [2.248]

Specifications	Units	08M-40	08M-50	08M-75
Stroke	mm (in)	40 [1.57]	50 [1.97]	75 [2.95]
Weight	kg (lb)	0.24 [0.522]	0.29 [0.633]	0.41 [0.911]
Displacement	cc (cu-in)	4.02 [0.245]	5.03 [0.307]	7.54 [0.460]
Max. Applied Load	N (lbf)	10 [2.248]	10 [2.248]	10 [2.248]

Deflection

(Note: Moment calculations located on page 31)

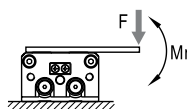
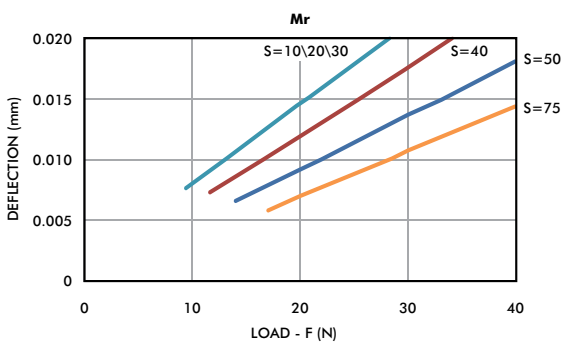
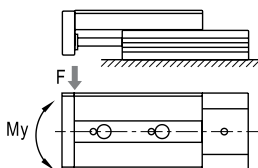
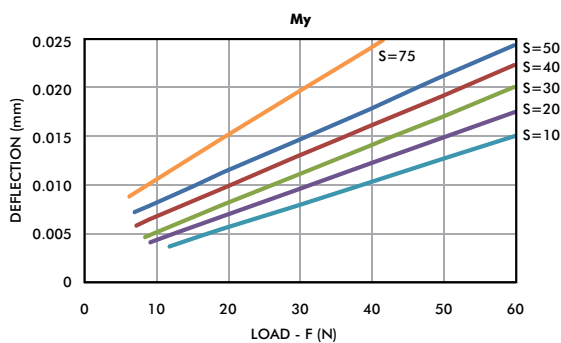
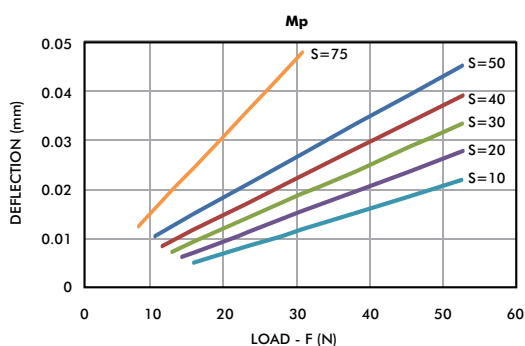

Payload vs. Velocity

TOP MOUNTING PAYLOAD vs. VELOCITY

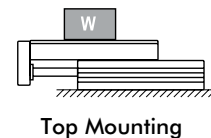
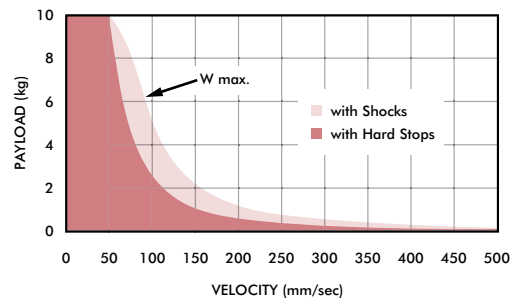

FRONT MOUNTING PAYLOAD vs. VELOCITY

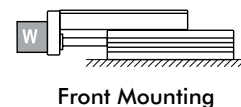
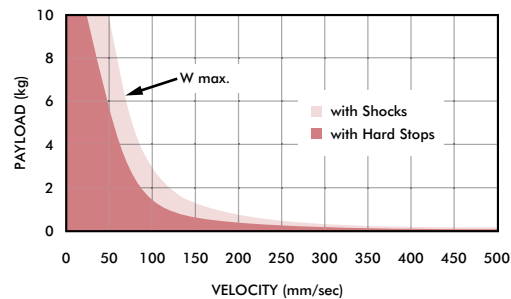

T110-12M

OEM Linear Slide | Dimensions and Technical Specifications



Specifications	Units	12M	
Thrust Force at 7 bar [100 psi]	Retract	N [lbf]	119 [26.8]
	Extend		158 [35.6]
Pressure Range	bar [psi]	1.5-7 [22-100]	
Cylinder Bore Diameter [x2]	mm [in]	12 [0.47]	
Speed Range	mm/sec [in/sec]	50-500 [2-20]	
End Stop Repeatability, Basic Unit	mm [in]	±0.5 [±0.02]	
End Stop Repeatability, Stop Kit	mm [in]	±0.2 [±0.01]	
End Stop Repeatability, Shock Kit	mm [in]	±0.02 [±0.001]	
Valve Required to Actuate		4 Way 2 Position	

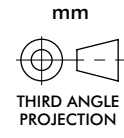
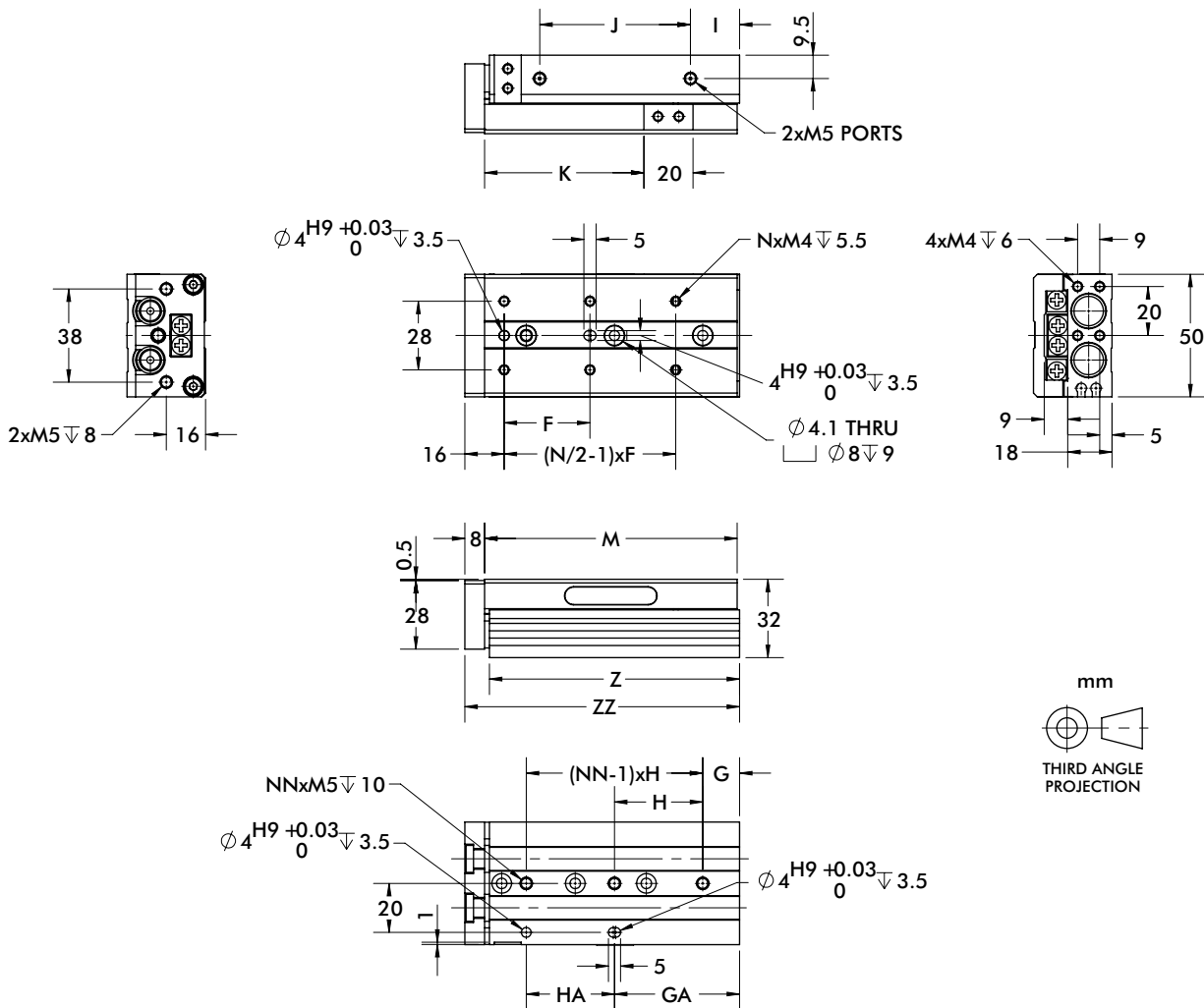

Stroke\Item	F	N	G	H	NN	GA	HA	I	J	K	M	Z	ZZ
10	35	4	15	40	2	15	40	10	39.5	25	71	70	80
20	35	4	15	40	2	15	40	10	39.5	35	71	70	80
30	35	4	15	40	2	15	40	10	39.5	45	71	70	80
40	50	4	17	25	3	42	25	10	51.5	55	83	82	92
50	35	6	15	36	3	51	36	20	61.5	65	103	102	112
75	55	6	25	36	4	61	72	40	87.5	90	149	148	158
100	65	6	35	38	5	111	76	50	131.5	115	203	202	212

Specifications	Units	12M-10	12M-20	12M-30	12M-40
Stroke	mm (in)	10 [0.39]	20 [0.79]	30 [1.18]	40 [1.57]
Weight	kg (lb)	0.33 [0.722]	0.33 [0.722]	0.33 [0.722]	0.39 [0.856]
Displacement	cc (cu-in)	2.26 [0.138]	4.52 [0.276]	6.79 [0.414]	9.05 [0.552]
Max. Applied Load	N (lbf)	20 [4.496]	20 [4.496]	20 [4.496]	20 [4.496]

Specifications	Units	12M-50	12M-75	12M-100
Stroke	mm (in)	50 [1.97]	75 [2.95]	100 [3.94]
Weight	kg (lb)	0.48 [1.067]	0.66 [1.467]	0.89 [1.978]
Displacement	cc (cu-in)	11.31 [0.690]	16.97 [1.035]	22.62 [1.381]
Max. Applied Load	N (lbf)	20 [4.496]	20 [4.496]	20 [4.496]

Deflection

(Note: Moment calculations located on page 31)

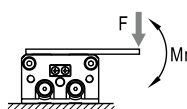
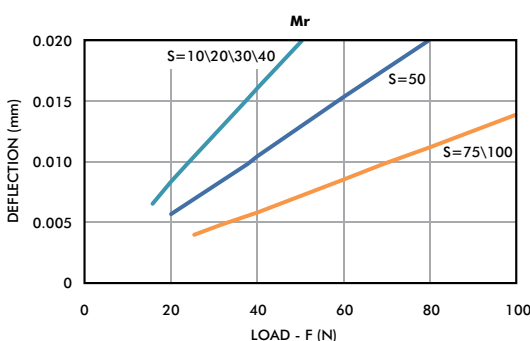
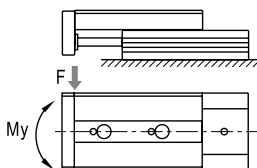
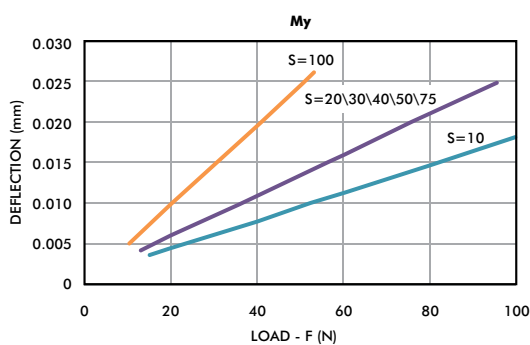
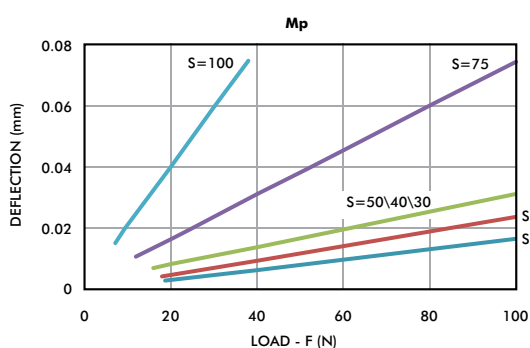

Payload vs. Velocity

TOP MOUNTING PAYLOAD vs. VELOCITY

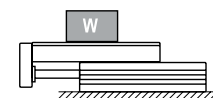
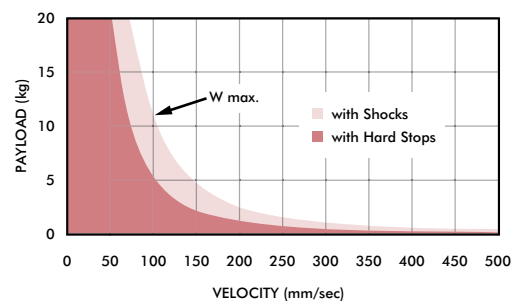

Top Mounting

FRONT MOUNTING PAYLOAD vs. VELOCITY

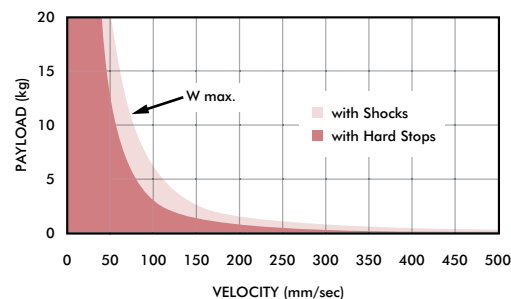

Front Mounting

T110-16M

OEM Linear Slide | Dimensions and Technical Specifications

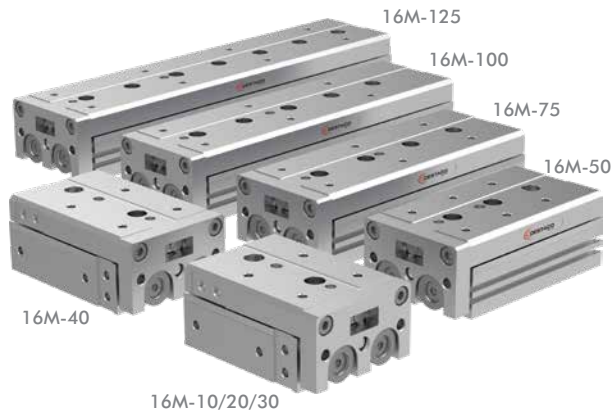

Specifications	Units	16M	
Thrust Force at 7 bar [100 psi]	Retract	N [lbf]	211 [47.4]
	Extend		281 [63.2]
Pressure Range	bar [psi]	1.5-7 [22-100]	
Cylinder Bore Diameter [x2]	mm [in]	16 [0.63]	
Speed Range	mm/sec [in/sec]	50-500 [2-20]	
End Stop Repeatability, Basic Unit	mm [in]	±0.5 [±0.02]	
End Stop Repeatability, Stop Kit	mm [in]	±0.2 [±0.01]	
End Stop Repeatability, Shock Kit	mm [in]	±0.02 [±0.001]	
Valve Required to Actuate		4 Way 2 Position	

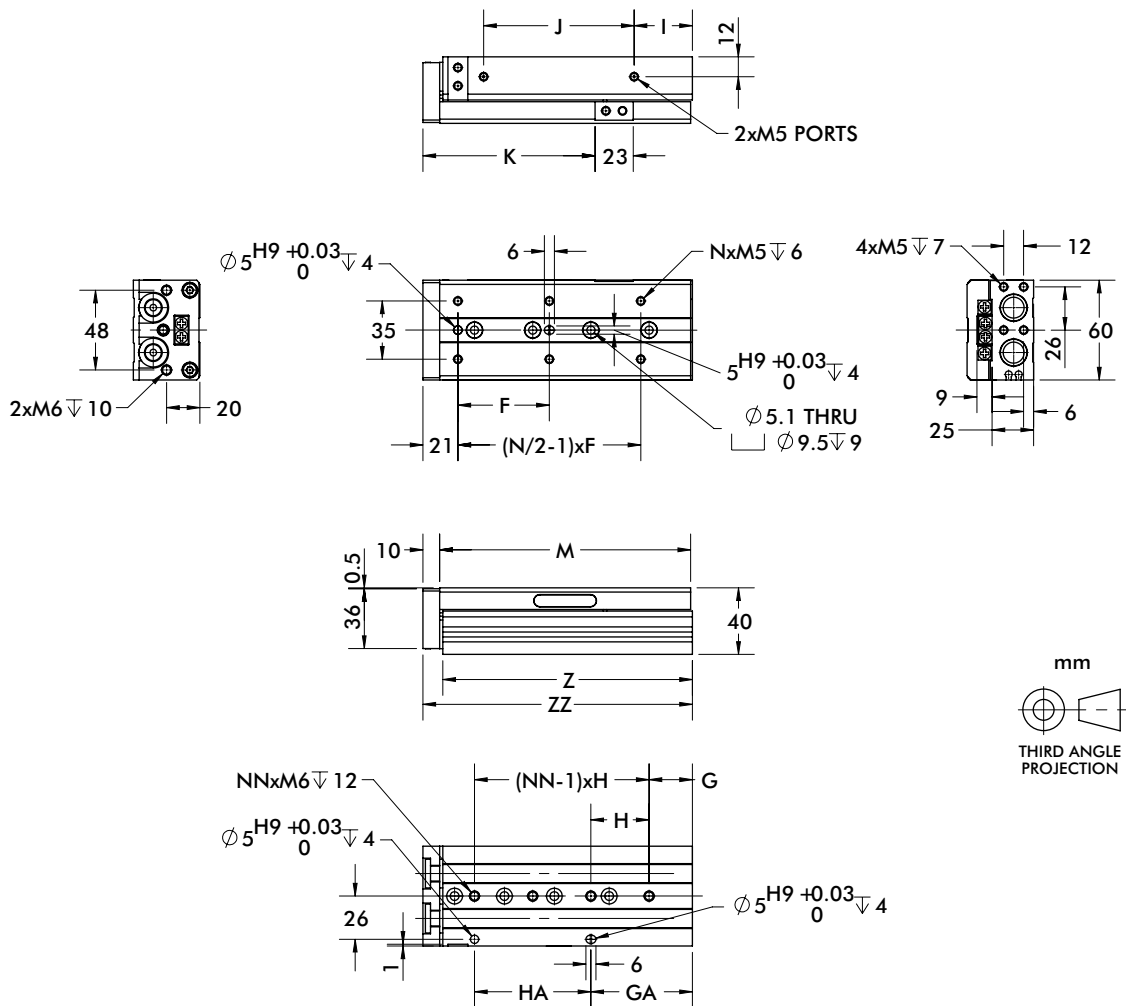

Stroke\Item	F	N	G	H	NN	GA	HA	I	J	K	M	Z	ZZ
10	35	4	16	40	2	16	40	8	42.5	28.5	76	75	87
20	35	4	16	40	2	16	40	8	42.5	38.5	76	75	87
30	35	4	16	40	2	16	40	8	42.5	48.5	76	75	87
40	40	4	16	50	2	16	50	8	52.5	58.5	86	85	97
50	30	6	21	30	3	51	30	12	63.5	68.5	101	100	112
75	55	6	26	35	4	61	70	35	90.5	93.5	151	150	162
100	65	6	39	35	5	109	70	55	118.5	118.8	199	198	210
125	70	8	19	35	7	159	70	70	153.5	143.5	249	248	260

Specifications	Units	16M-10	16M-20	16M-30	16M-40
Stroke	mm (in)	10 [0.39]	20 [0.79]	30 [1.18]	40 [1.57]
Weight	kg (lb)	0.57 [1.267]	0.57 [1.267]	0.58 [1.289]	0.64 [1.422]
Displacement	cc (cu-in)	4.02 [0.245]	8.04 [0.491]	12.07 [0.736]	16.09 [0.982]
Max. Applied Load	N (lbf)	35 [7.868]	35 [7.868]	35 [7.868]	35 [7.868]

Specifications	Units	16M-50	16M-75	16M-100	16M-125
Stroke	mm (in)	50 [1.97]	75 [2.95]	100 [3.94]	125 [4.92]
Weight	kg (lb)	0.76 [1.689]	1.09 [2.422]	1.37 [3.044]	1.70 [3.778]
Displacement	cc (cu-in)	20.11 [1.227]	30.16 [1.841]	40.22 [2.454]	50.27 [3.068]
Max. Applied Load	N (lbf)	35 [7.868]	35 [7.868]	35 [7.868]	35 [7.868]

Deflection

(Note: Moment calculations located on page 31)

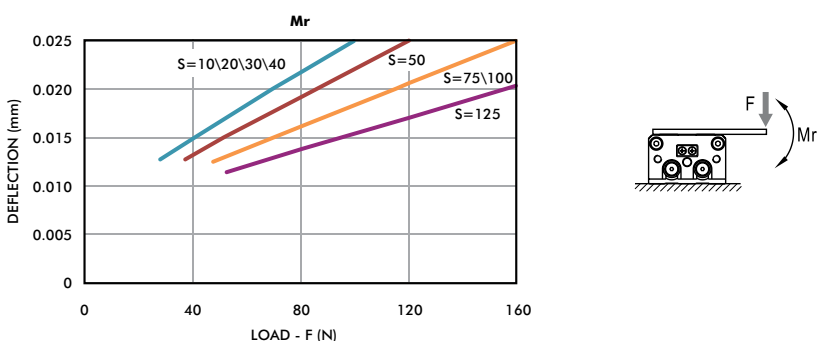
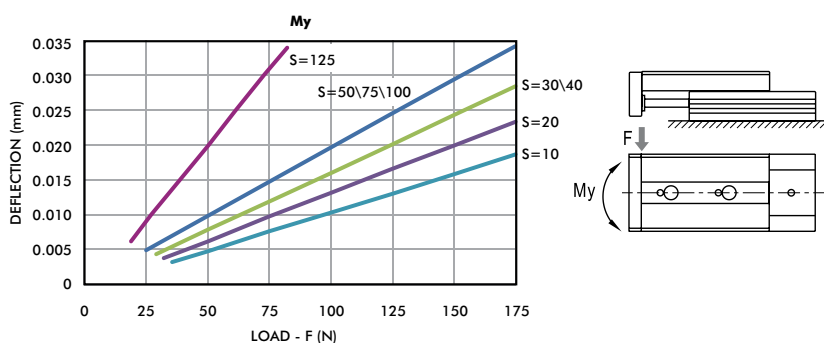
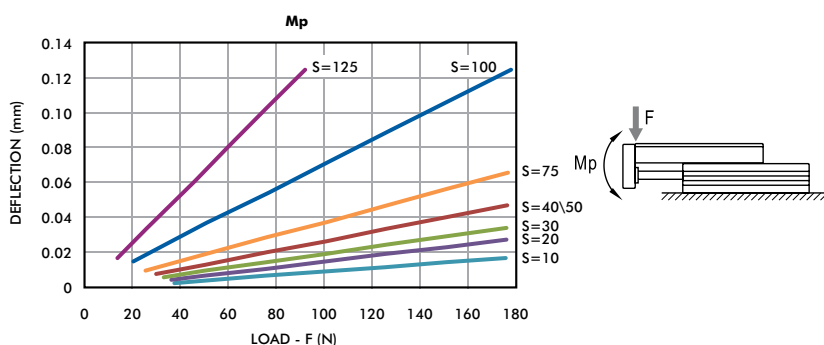

Payload vs. Velocity

TOP MOUNTING PAYLOAD vs. VELOCITY

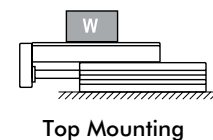
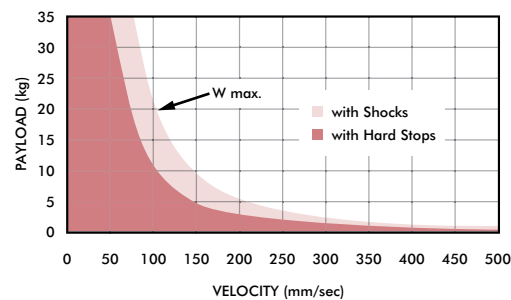

FRONT MOUNTING PAYLOAD vs. VELOCITY

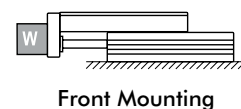
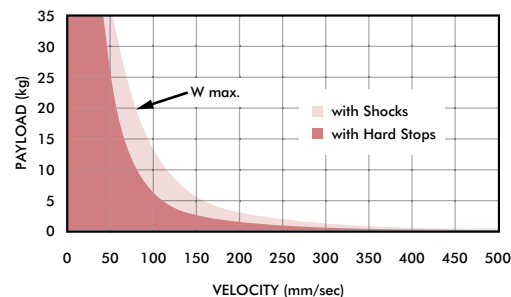

T110-20M

OEM Linear Slide | Dimensions and Technical Specifications

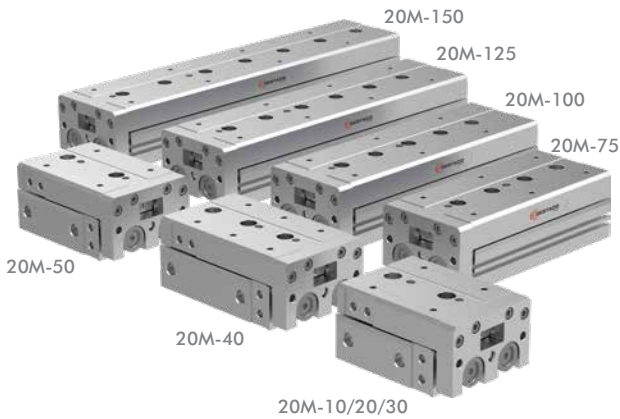

Specifications	Units	20M	
Thrust Force at 7 bar [100 psi]	Retract	N [lbf]	330 [74.2]
	Extend		440 [99.0]
Pressure Range	bar [psi]	1.5-7 [22-100]	
Cylinder Bore Diameter [x2]	mm [in]	20 [0.78]	
Speed Range	mm/sec [in/sec]	50-500 [2-20]	
End Stop Repeatability, Basic Unit	mm [in]	±0.5 [±0.02]	
End Stop Repeatability, Stop Kit	mm [in]	±0.2 [±0.01]	
End Stop Repeatability, Shock Kit	mm [in]	±0.02 [±0.001]	
Valve Required to Actuate		4 Way 2 Position	

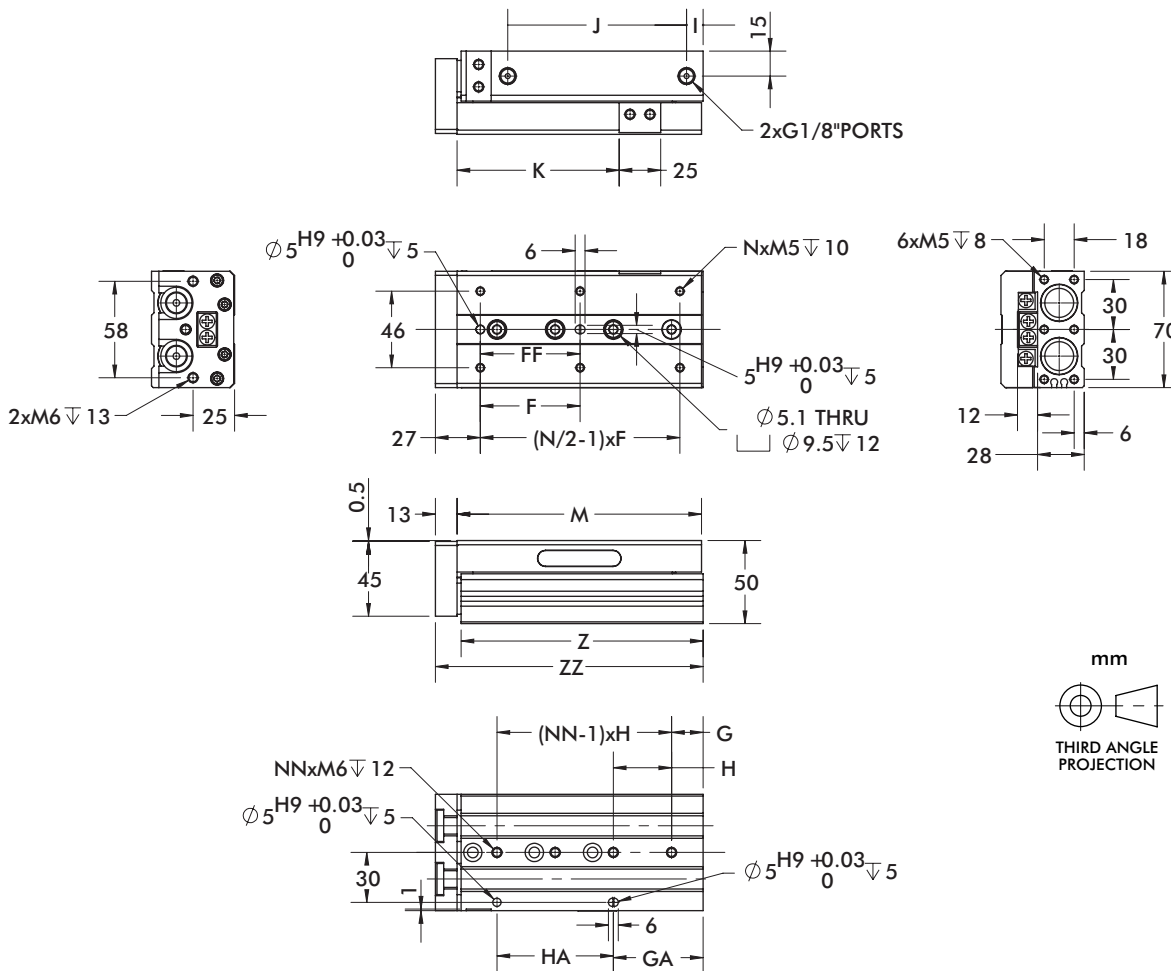

Stroke \ Item	F	FF	N	G	H	NN	GA	HA	I	J	K	M	Z	ZZ
10	50	40	4	15	45	2	25	35	10	43.5	32.5	83	81.5	97
20	50	40	4	15	45	2	25	35	10	43.5	42.5	83	81.5	97
30	50	40	4	15	45	2	25	35	10	43.5	52.5	83	81.5	97
40	60	50	4	15	55	2	35	35	10	53.5	62.5	93	91.5	107
50	35	35	6	15	35	3	50	35	10	68.5	72.5	108	106.5	122
75	60	60	6	19	35	4	54	70	10	107.5	97.5	147	145.5	161
100	70	70	6	37	35	5	107	70	55	115.5	122.5	200	198.5	214
125	70	70	8	41	38	6	155	76	70	154.5	147.5	254	252.5	268
150	80	80	8	19	44	7	195	88	90	186.5	172.5	306	304.5	320

Specifications	Units	20M-10	20M-20	20M-30	20M-40	20M-50
Stroke	mm (in)	10 [0.39]	20 [0.79]	30 [1.18]	40 [1.57]	50 [1.97]
Weight	kg (lb)	0.96 [2.133]	0.98 [2.178]	1.01 [2.244]	1.10 [2.44]	1.25 [2.778]
Displacement	cc (cu-in)	6.28 [0.383]	12.57 [0.767]	18.85 [1.150]	25.14 [1.534]	31.42 [1.917]
Max. Applied Load	N (lbf)	55 [12.364]	55 [12.364]	55 [12.364]	55 [12.364]	55 [12.364]

Specifications	Units	20M-75	20M-100	20M-125	20M-150
Stroke	mm (in)	75 [2.95]	100 [3.94]	125 [4.92]	150 [5.91]
Weight	kg (lb)	1.63 [3.622]	2.15 [4.778]	2.67 [5.933]	3.19 [7.089]
Displacement	cc (cu-in)	47.13 [2.876]	62.84 [3.838]	78.55 [4.793]	94.26 [5.752]
Max. Applied Load	N (lbf)	55 [12.364]	55 [12.364]	55 [12.364]	55 [12.364]

Deflection

(Note: Moment calculations located on page 31)

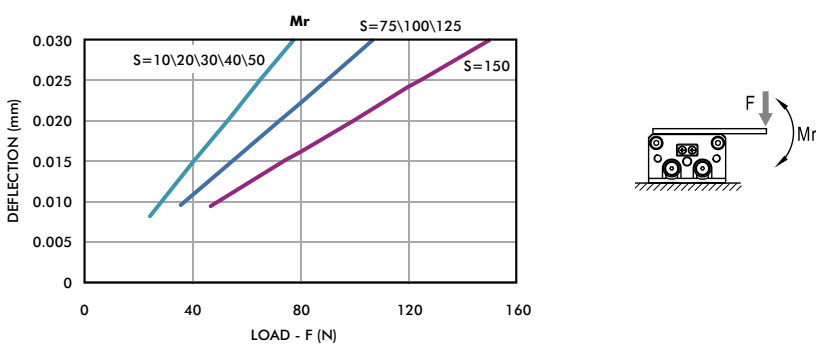
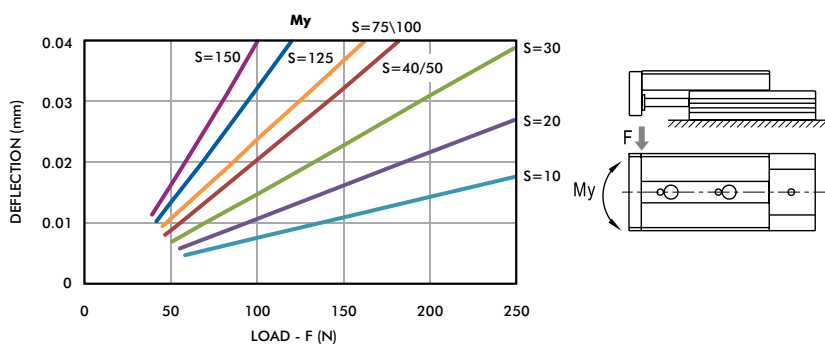
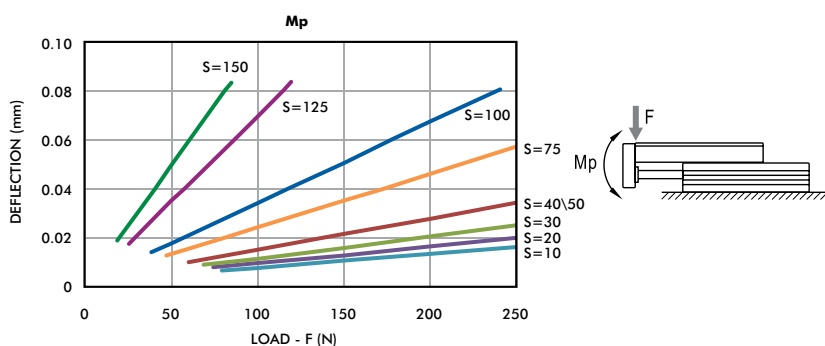

Payload vs. Velocity

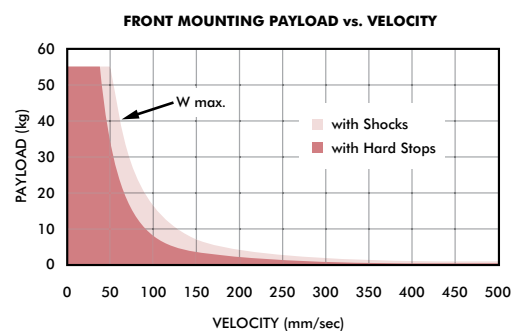
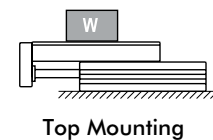
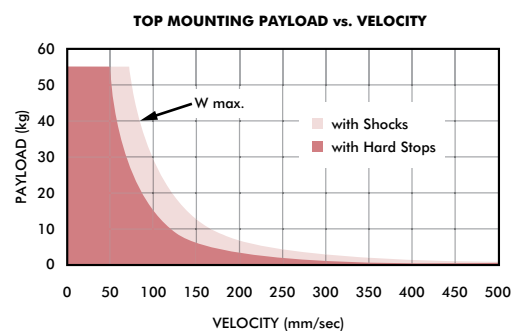

T110-25M

OEM Linear Slide | Dimensions and Technical Specifications

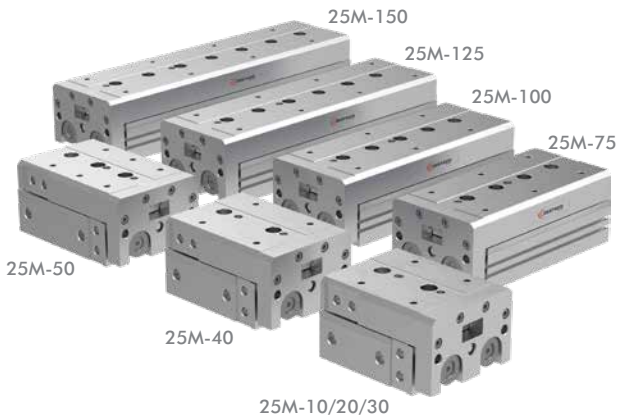

Specifications	Units	25M	
Thrust Force at 7 bar [100 psi]	Retract	N [lbf]	529 [119.0]
	Extend		687 [154.5]
Pressure Range	bar [psi]	1.5-7 [22-100]	
Cylinder Bore Diameter [x2]	mm [in]	25 [0.98]	
Speed Range	mm/sec [in/sec]	50-500 [2-20]	
End Stop Repeatability, Basic Unit	mm [in]	±0.5 [±0.02]	
End Stop Repeatability, Stop Kit	mm [in]	±0.2 [±0.01]	
End Stop Repeatability, Shock Kit	mm [in]	±0.02 [±0.001]	
Valve Required to Actuate		4 Way 2 Position	

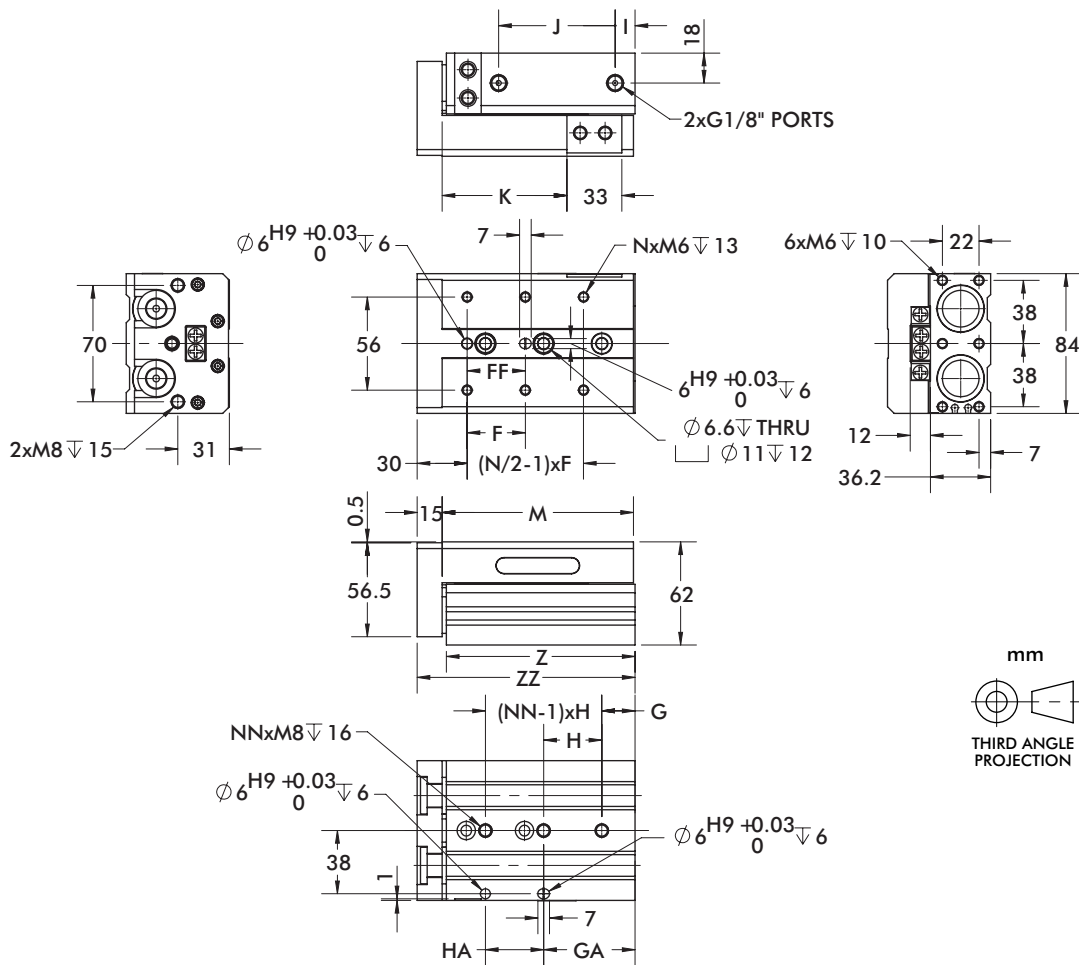

Stroke\Item	F	FF	N	G	H	NN	GA	HA	I	J	K	M	Z	ZZ
10	50	40	4	22	45	2	22	45	12	47	35	92	90.5	108
20	50	40	4	22	45	2	22	45	12	47	45	92	90.5	108
30	50	40	4	22	45	2	22	45	12	47	55	92	90.5	108
40	60	50	4	22	55	2	22	55	12	57	65	102	100.5	118
50	35	35	6	20	35	3	55	35	12	70	75	115	113.5	131
75	60	60	6	26	35	4	61	70	33	90	100	156	154.5	172
100	70	70	6	32	35	5	102	70	45	119	125	197	195.5	213
125	75	75	8	40	38	6	154	76	67	155	150	255	253.5	271
150	80	80	8	30	40	7	190	80	82	180	175	295	293.5	311

Specifications	Units	25M-10	25M-20	25M-30	25M-40	25M-50
Stroke	mm (in)	10 [0.39]	20 [0.79]	30 [1.18]	40 [1.57]	50 [1.97]
Weight	kg (lb)	1.66 [3.689]	1.68 [3.733]	1.69 [3.756]	1.84 [4.089]	2.09 [4.644]
Displacement	cc (cu-in)	9.82 [0.599]	19.64 [1.198]	29.46 [1.798]	39.28 [2.397]	49.09 [2.996]
Max. Applied Load	N (lbf)	70 [15.737]	70 [15.737]	70 [15.737]	70 [15.737]	70 [15.737]

Specifications	Units	25M-75	25M-100	25M-125	25M-150
Stroke	mm (in)	75 [2.95]	100 [3.94]	125 [4.92]	150 [5.91]
Weight	kg (lb)	2.65 [5.889]	3.27 [7.267]	4.14 [9.1]	4.71 [10.467]
Displacement	cc (cu-in)	73.645 [4.494]	98.19 [5.992]	122.73 [7.490]	147.28 [8.922]
Max. Applied Load	N (lbf)	70 [15.737]	70 [15.737]	70 [15.737]	70 [15.737]

Deflection

(Note: Moment calculations located on page 31)

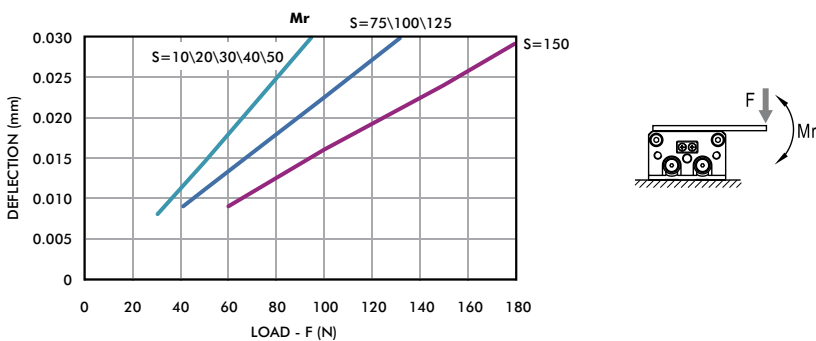
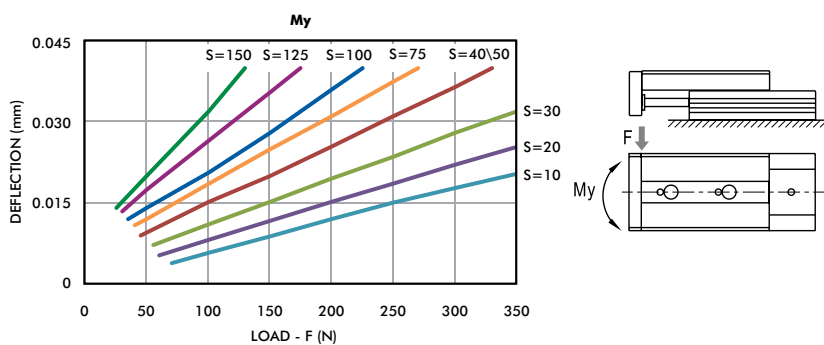
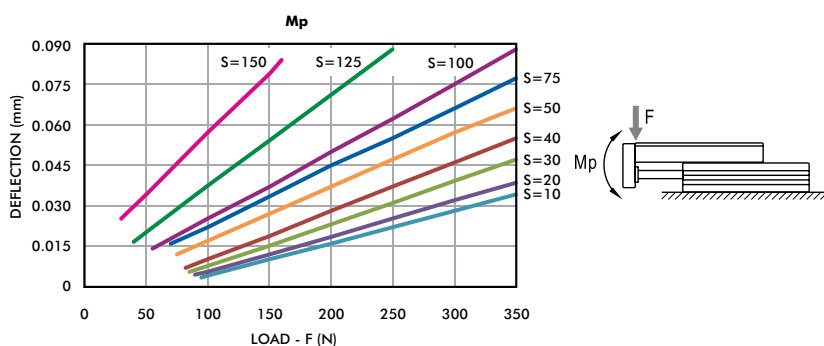

Payload vs. Velocity

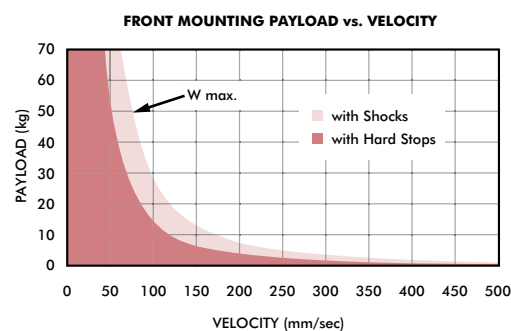
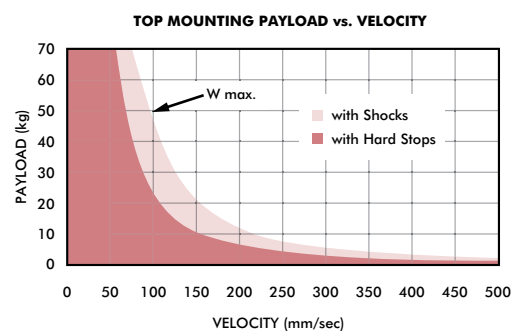

T110 SERIES

OEM Linear Slide | Offset Loading Formula

	Horizontal Mounting	Side Mounting	Vertical Mounting
Pitch 	Static Moment: $M_p = \frac{W \times (L1+A)}{1000}$ Dynamic Moment: $M_{po} = \frac{W \times (L1+A)}{1000} + \frac{W \times a \times (L2+B)}{1000 \times g}$	Static Moment: $M_p = 0$ Dynamic Moment: $M_{po} = \frac{W \times a \times (L2+B)}{1000 \times g}$	Static Moment: $M_p = \frac{W \times (L2+B)}{1000}$ Dynamic Moment: $M_{po} = \frac{W \times (L2+B)}{1000} + \frac{W \times a \times (L2+B)}{1000 \times g}$
Roll 	Static Moment: $M_r = \frac{W \times (C+L3)}{1000}$ Dynamic Moment: $M_{ro} = \text{Static Moment}$	Static Moment: $M_r = \frac{W \times (B+L2)}{1000}$ Dynamic Moment: $M_{ro} = \text{Static Moment}$	Static Moment: $M_r = 0$ Dynamic Moment: $M_{ro} = 0$
Yaw 	Static Moment: $M_y = 0$ Dynamic Moment: $M_{yo} = \frac{W \times a \times (C+L3)}{1000 \times g}$	Static Moment: $M_y = \frac{W \times (A+L1)}{1000}$ Dynamic Moment: $M_{yo} = \frac{W \times a \times (C+L3)}{1000 \times g} + \frac{W \times (A+L1)}{1000}$	Static Moment: $M_y = \frac{W \times (C+L3)}{1000}$ Dynamic Moment: $M_{yo} = \frac{W \times a \times (C+L3)}{1000 \times g} + \frac{W \times (C+L3)}{1000}$

Instructions:

1. Select mounting configuration, Horizontal, Side or Vertical
2. Define position of payload center of gravity L1, L2 & L3. A, B & C can be found in table 2
3. Calculate both static and dynamic moments for pitch, roll and yaw for your mounting configuration
4. Calculate combined moments with respect to max allowable (table 2). Must be less than or equal to 1.

$$\text{Static } \frac{M_p}{M_{p_{\max}}} + \frac{M_y}{M_{y_{\max}}} + \frac{M_r}{M_{r_{\max}}} \leq 1$$

$$\text{Dynamic } \frac{M_{po}}{M_{po_{\max}}} + \frac{M_{yo}}{M_{yo_{\max}}} + \frac{M_{ro}}{M_{ro_{\max}}} \leq 1$$

Table 1. Symbol and Unit of Measure

Symbol	Item	Unit
A, B, C	Correction value for center position distance of moment (See Table 2)	mm
a	Acceleration due to inertia (See below)	m/s ²
g	Acceleration due to gravity g=9.81	m/s ²
L1, L2, L3	Overhang (customer supplied)	mm
Mp, My, Mr	Static moment (Pitch, Yaw, Roll)	Nm
Mp _{max} , My _{max} , Mr _{max}	Maximum allowable static moment (Pitch, Yaw, Roll. See Table 2)	Nm
Mpo, Myo, Mro	Dynamic moment (Pitch, Yaw, Roll)	Nm
Mpo _{max} , Myo _{max} , Mro _{max}	Maximum allowable dynamic moment (Pitch, Yaw, Roll. See Table 2)	Nm
Va	Average speed (customer supplied)	mm/s
W	Payload (customer supplied)	N

Acceleration due to inertia: Bumper: $a = 1600 \times (Va/1000)^2$

Shock Absorber: $a = 400 \times (Va/1000)^2$

Table 2. Maximum Allowable Moments

Bore Size	Stroke (mm)	Dynamic Moment (Nm)			Static Moment (Nm)			Correction Value (mm)		
		M _{po} _{max}	M _{yo} _{max}	M _{ro} _{max}	M _p _{max}	M _y _{max}	M _r _{max}	A	B	C
06M	10	3.3	3.8	2.6	0.7	0.7	0.6	27	7.3	16
	20	3.3	3.8	2.6	0.7	0.8	0.6	42		
	30	3.3	3.8	2.6	0.7	0.8	0.6	52		
	40	7.2	7.9	3.6	1.3	1.3	0.6	72		
	50	12.4	12.7	4.7	1.8	1.8	0.6	87		
08M	10	10.1	9.1	8.8	2.5	2.5	2	32	8.5	20
	20	10.1	9.1	8.8	2.6	2.6	2	42		
	30	10.1	9.1	8.8	2.8	2.8	2	57		
	40	12.4	10.8	10.1	3.4	3.4	2.3	72		
	50	23.6	24.8	13.9	4.4	4.4	2.1	92		
	75	32.8	35.3	16.4	4.6	4.6	1.8	132		
12M	10	33	34.3	30.9	7.3	7.3	5.8	48	10	25
	20	33	34.3	30.9	7.6	7.6	5.8	58		
	30	33	34.3	30.9	7.8	7.8	5.8	68		
	40	33	34.3	30.9	8	8	5.8	78		
	50	53.4	49.6	39.7	9.8	9.8	5.8	88		
	75	78.8	71.9	48.6	14.2	14.2	6.8	125		
	100	78.8	71.9	48.6	14.7	14.7	6.8	160		
16M	10	33	34.3	30.9	8.8	8.8	7.6	43	11	30
	20	33	34.3	30.9	9.2	9.2	7.6	53		
	30	33	34.3	30.9	9.5	9.5	7.6	63		
	40	33	34.3	30.9	10	10	7.6	78		
	50	53.4	49.6	39.7	12.2	12.2	7.6	93		
	75	78.8	71.9	48.6	17.6	17.6	8.9	130		
	100	78.8	71.9	48.6	18.2	18.2	8.9	165		
	125	143.7	144.5	53.3	24.8	24.8	7.8	204		
20M	10	60.1	50.5	72.8	14.5	14.5	15.2	47	16.5	35
	20	60.1	50.5	72.8	15.2	15.2	15.2	57		
	30	60.1	50.5	72.8	15.7	15.7	15.2	67		
	40	60.1	50.5	72.8	16.3	16.3	15.2	82		
	50	60.1	50.5	72.8	16.6	16.6	15.2	92		
	75	169.3	154.3	114.4	41.2	41.2	22	136		
	100	169.3	154.3	114.4	42.8	42.8	22	176		
	125	169.3	154.3	114.4	43.6	43.6	22	205		
	150	267.5	286.6	145.6	49	49	20.5	249		
25M	10	60.1	50.5	72.8	16.3	16.3	17.6	52	20.3	42
	20	60.1	50.5	72.8	17	17	17.6	62		
	30	60.1	50.5	72.8	17.4	17.4	17.6	72		
	40	60.1	50.5	72.8	17.8	17.8	17.6	82		
	50	60.1	50.5	72.8	18.2	18.2	17.6	96		
	75	169.3	154.3	114.4	45.2	45.2	25.3	141		
	100	169.3	154.3	114.4	46.2	46.2	25.3	165		
	125	169.3	154.3	114.4	48	48	25.3	210		
	150	267.5	286.6	145.6	65	65	28.3	254		