

G110 SERIES

OEM Parallel Grippers | Features and Benefits | How To Order

Features:

- 20 different models sized to match your application needs
- Fast actuations from 60mS
- Multiple stroke options from 5mm to 50mm
- High grip force, small package from 56N to 558N [13 to 125 lbf]
- Shielded design for clean to moderate manufacturing environments
- Interchangeable gripper fingers with competitive units using extended jaw option
- Locating sleeves for precise finger mounting included with gripper



How To Order

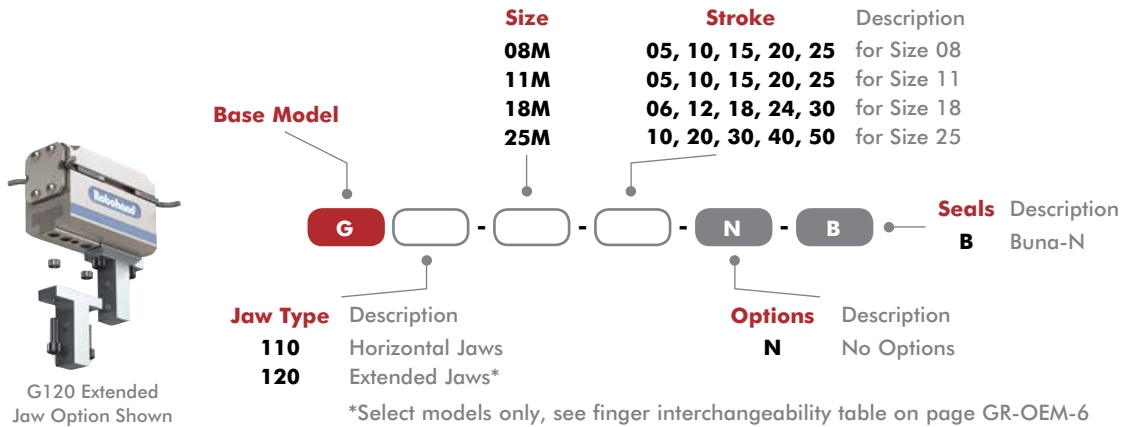

Accessories

G110 Common Accessories	Model Numbers	Part Number	Qty/Unit
Sensor, NPN magneto resistive type, 4mm Barrel	All Models	OHSN-021	1-4
Sensor, PNP magneto resistive type, 4mm Barrel	All Models	OHSP-021	1-4
Cable straight, quick disconnect, socket, 3 conductor, 2M length	All Models	CABL-010	1-4

*Sensor and cable sold separately.



Cable Straight, Quick Disconnect, Socket, 3 Conductor, 2M Length



Long Barrel 4mm Straight Sensor

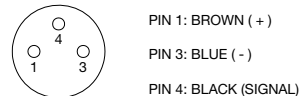
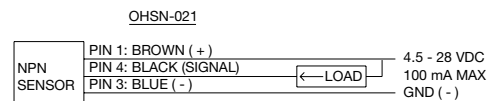

G110-08M, G120-08M	Part Number	Qty/Unit
Pneumatic air fitting, straight M3 screw to 3mm tube push-in	PLFT-021	2
Jaw locating sleeve for precise finger mounting	20961-11	4
Seal Kit (includes): End gasket G110-08M (Qty 2) Seal: U-cup Buna replacement seal (Qty 4) Button head socket cap screws (Qty 8)	SLKT-244	1
G110-11M, G120-11M	Part Number	Qty/Unit
Pneumatic air fitting, straight M3 screw to 3mm tube push-in	PLFT-021	2
Jaw locating sleeve for precise finger mounting	20961-11	4
Seal Kit (includes): End gasket G110-11M (Qty 2) Seal: U-cup Buna replacement seal (Qty 4) Button head socket cap screws (Qty 8)	SLKT-245	1
G110-18M, G120-18M	Part Number	Qty/Unit
Pneumatic air fitting, right angle, M5 screw to 6mm tube push-in	PLFT-041	2
Valve kit, failsafe, M5 ports	OFSV-004	1
Jaw locating sleeve for precise finger mounting	20962-11	4
Seal Kit (includes): End gasket G110-18M (Qty 2) Seal: U-cup Buna replacement seal (Qty 4) Button head socket cap screws (Qty 8)	SLKT-246	1
G110-25M, G120-25M	Part Number	Qty/Unit
Pneumatic air fitting, right angle, M5 screw to 6mm tube push-in	PLFT-041	2
Valve kit, failsafe, M5 ports	OFSV-004	1
Jaw locating sleeve for precise finger mounting	20963-11	4
Seal Kit (includes): End gasket G110-25M (Qty 2) Seal: U-cup Buna replacement seal (Qty 4) Button head socket cap screws (Qty 8)	SLKT-247	1



Pneumatic Air Fittings



End Gasket



Jaw Locating Sleeve for Precise Finger Mounting



Valve Kit, Failsafe, M5 Ports



U-cup Buna Replacement Seal



Button Head Socket Cap Screws

G110 SERIES

OEM Parallel Grippers | Quick Installation Kits

Commissioning Kits for Easy Ordering

- Includes just what you need for easy installation
- One quick installation kit required per gripper
- Fast, simple convenient ordering



2 Sensors



2 Air Fittings



4 Jaw Locating Finger Sleeves



4 Finger Mounting Screws

	Includes	Part Number	Qty/Kit
G110-08M, G120-08M			
Sensor, PNP magneto resistive type, 4mm barrel	OHSP-021	G110-QKST-101	2
Pneumatic air fitting, M3 screw to 3mm tube push-in	PLFT-021		2
Jaw locating sleeve for precise finger mounting	20961-11		4
Finger mounting screws	SHSM025C10		4
G110-11M, G120-11M			
Sensor, PNP magneto resistive type, 4mm barrel	OHSP-021	G110-QKST-102	2
Pneumatic air fitting, M3 screw to 3mm tube push-in	PLFT-021		2
Jaw locating sleeve for precise finger mounting	20961-11		4
Finger mounting screws	SHSM03C10		4
G110-18M, G120-18M			
Sensor, PNP magneto resistive type, 4mm barrel	OHSP-021	G110-QKST-103	2
Pneumatic air fitting, right angle, M5 screw to 6mm tube push-in	PLFT-041		2
Jaw locating sleeve for precise finger mounting	20962-11		4
Finger mounting screws	SHSM04C12		4
G110-25M, G120-25M			
Sensor, PNP magneto resistive type, 4mm barrel	OHSP-021	G110-QKST-104	2
Pneumatic air fitting, right angle, M5 screw to 6mm tube push-in	PLFT-041		2
Jaw locating sleeve for precise finger mounting	20963-11		4
Finger mounting screws	SHSM05C16		4

G110 Series Interchangeable Fingers with Extended Gripper Jaw Option. Fast Gripper Commissioning

- Re-use your existing gripper fingers
- Same finger mounting hole pattern as competitive units
- G110 Series Grippers Deliver:
 - Low Maintenance Shielded Design
 - Smooth Rack and Pinion Operation
 - Fast actuations from 60mS
 - Low height profile
 - All-in-one Commissioning Kits

G120 Extended Jaw Option: 100% Finger Compatible



G120 Extended Jaw Option, Finger Interchangeability Table*

(G120 units ship with extended jaw option installed)

Extended Jaw Option Part Number	Mounts to G110 Series Part Number	Compatible with SMC Part Number	Application Notes
G110-FNGR-08M-05	G110-08M-05-N-B	MHZ2-10	G110 has 1mm extra stroke, 9N extra force
G110-FNGR-08M-10	G110-08M-10-N-B	MHZL2-10	G110 has 2mm extra stroke, 10N extra force
G110-FNGR-11M-05	G110-11M-05-N-B	MHZ2-16	G110 has 1mm extra stroke, 13N less force
G110-FNGR-11M-10	G110-11M-10-N-B	MHZL2-16	G110 has 2mm extra stroke, 11N less force
G110-FNGR-18M-12	G110-18M-12-N-B	MHZ2-25	G110 has 2mm extra stroke, 24N extra force
G110-FNGR-18M-24	G110-18M-24-N-B	MHZL2-25	G110 has 2mm extra stroke, 46N extra force
G110-FNGR-25M-20	G110-25M-20-N-B	MHZ2-32	G110 has 2mm extra stroke, 20N less force

*Verify acceptable stroke and force changes in the table above for your application. G120 units are shipped with the extended jaw option mounted from factory. SMC is a registered trademark of SMC Corporation.

G110-08M

OEM Parallel Grippers | Dimensions and Technical Specifications



Specifications	Units	08M
Total Rated Grip Force	N [lbf]	56 [13]
Pressure Range	bar [psi]	3-7 [40-100]
Cylinder Bore Diameter	mm [in]	8 [0.31]
Temperature Range (Buna-N Seals)	°C [°F]	-35°~80° [-30°~180°]
Accuracy	mm [in]	±.05 [0.002]
Repeatability	mm [in]	±.05 [0.002]
Valve Required to Actuate		4 way 2 position

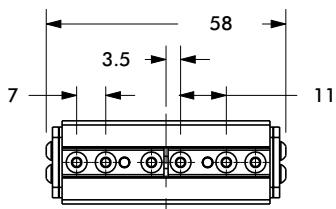
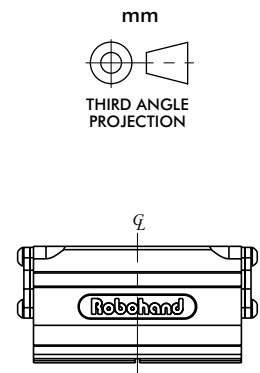
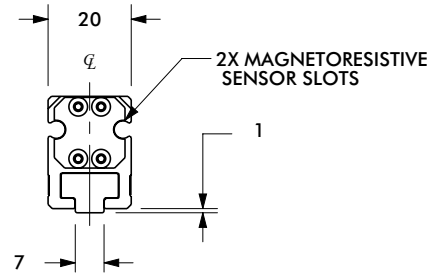
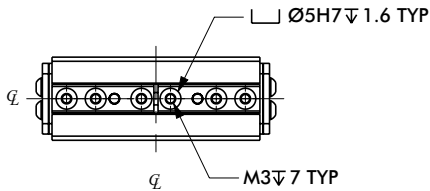
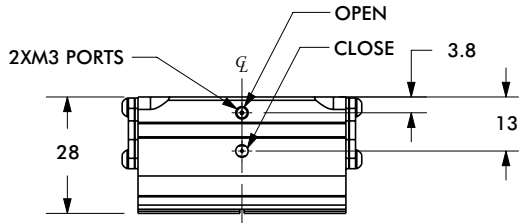
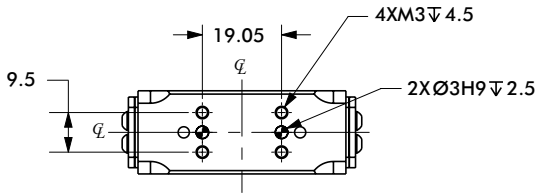

G110-08M-10

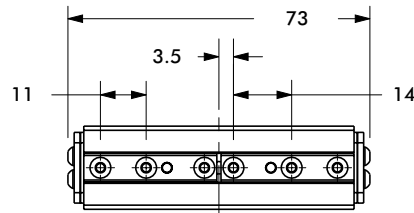

G110-08M-15

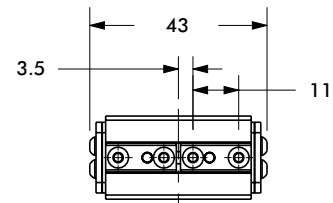

G110-08M-05

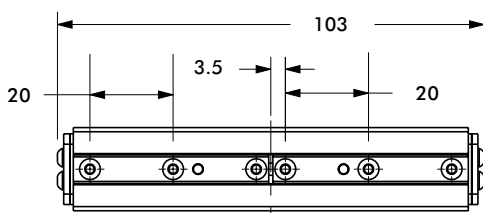

G110-08M-25

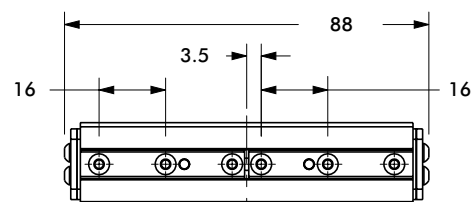

G110-08M-20

OEM Parallel Grippers | Technical Specifications

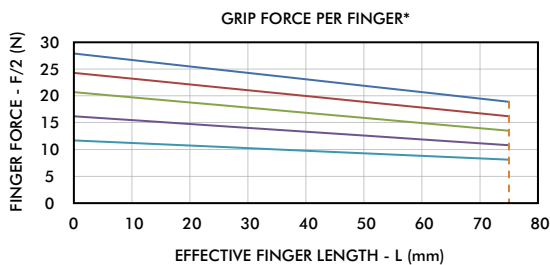
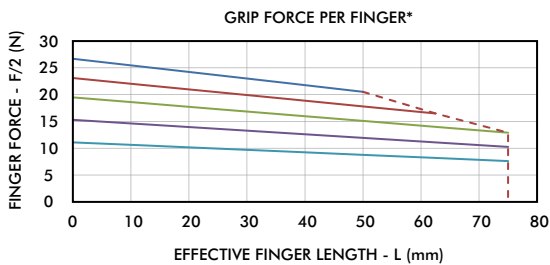
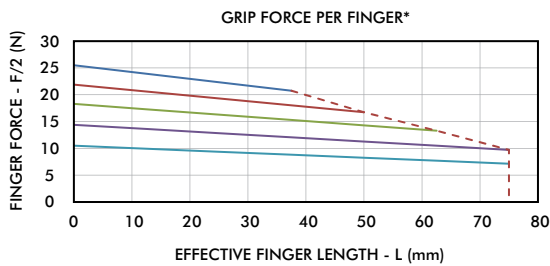
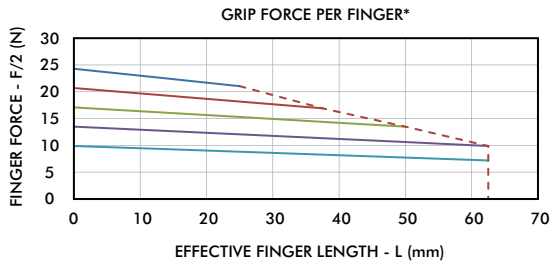
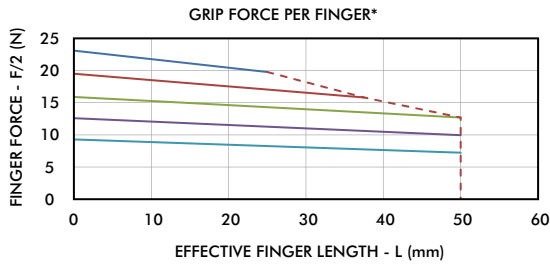

Specifications	Units	08M-05
Stroke	mm [in]	5 [0.20]
Weight	kg [lbs]	0.06 [0.13]
Displacement	cc [cu-in]	0.3 [0.02]
Actuation (open/close)	sec.	0.06
Max Tensile Load on Jaws	N [lbf]	156 [35]
Max Compressive Load on Jaws	N [lbf]	356 [80]
Max Moment on Jaws	Nm [in-lbs]	3.4 [30]

Specifications	Units	08M-10
Stroke	mm [in]	10 [0.39]
Weight	kg [lbs]	0.09 [0.20]
Displacement	cc [cu-in]	0.5 [0.03]
Actuation (open/close)	sec.	0.07
Max Tensile Load on Jaws	N [lbf]	178 [40]
Max Compressive Load on Jaws	N [lbf]	378 [86]
Max Moment on Jaws	Nm [in-lbs]	4 [35]

Specifications	Units	08M-15
Stroke	mm [in]	15 [0.59]
Weight	kg [lbs]	0.11 [0.24]
Displacement	cc [cu-in]	0.7 [0.05]
Actuation (open/close)	sec.	0.08
Max Tensile Load on Jaws	N [lbf]	200 [45]
Max Compressive Load on Jaws	N [lbf]	400 [90]
Max Moment on Jaws	Nm [in-lbs]	4.6 [40]

Specifications	Units	08M-20
Stroke	mm [in]	20 [0.79]
Weight	kg [lbs]	0.14 [0.31]
Displacement	cc [cu-in]	1.0 [0.06]
Actuation (open/close)	sec.	0.09
Max Tensile Load on Jaws	N [lbf]	222 [50]
Max Compressive Load on Jaws	N [lbf]	423 [95]
Max Moment on Jaws	Nm [in-lbs]	5.0 [45]

Specifications	Units	08M-25
Stroke	mm [in]	25 [0.98]
Weight	kg [lbs]	0.17 [0.37]
Displacement	cc [cu-in]	1.2 [0.08]
Actuation (open/close)	sec.	0.10
Max Tensile Load on Jaws	N [lbf]	245 [55]
Max Compressive Load on Jaws	N [lbf]	445 [100]
Max Moment on Jaws	Nm [in-lbs]	5.6 [50]

G110-11M

OEM Parallel Grippers | Dimensions and Technical Specifications



Specifications	Units	11M
Total Rated Grip Force	N [lbf]	104 [23]
Pressure Range	bar [psi]	3-7 [40-100]
Cylinder Bore Diameter	mm [in]	11 [0.44]
Temperature Range (Buna-N Seals)	°C [°F]	-35°~80° [-30°~180°]
Accuracy	mm [in]	±.05 [0.002]
Repeatability	mm [in]	±.05 [0.002]
Valve Required to Actuate		4 way 2 position

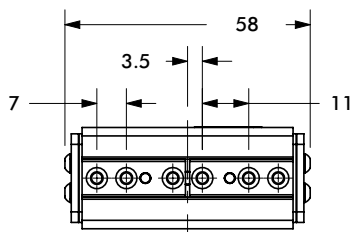
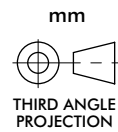
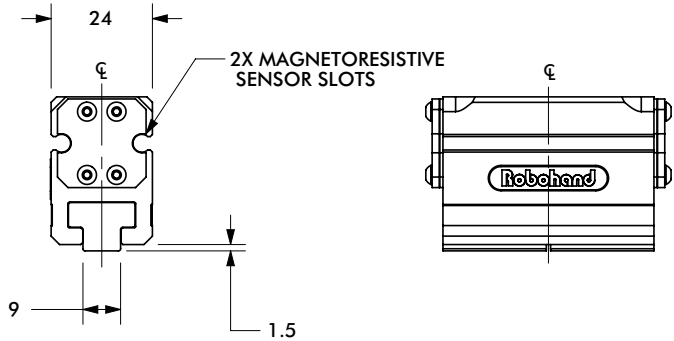
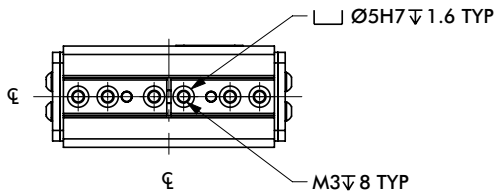
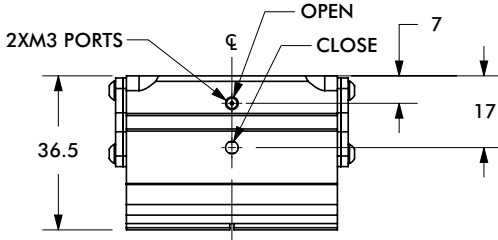
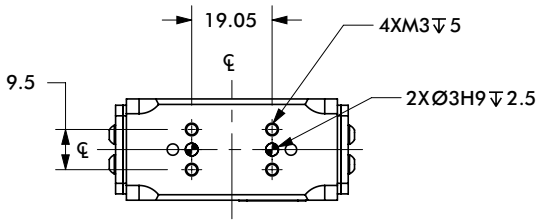

G110-11M-10

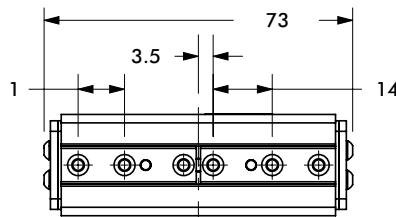

G110-11M-15

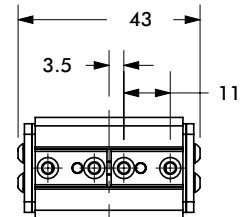

G110-11M-05

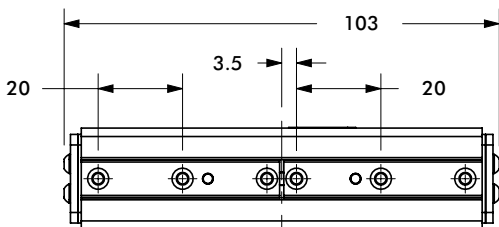

G110-11M-25

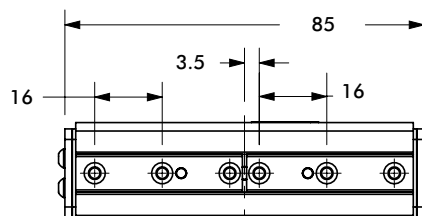

G110-11M-20

OEM Parallel Grippers | Technical Specifications

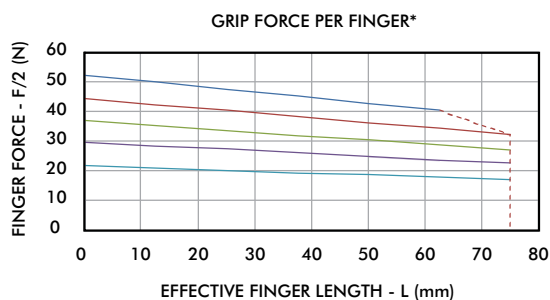
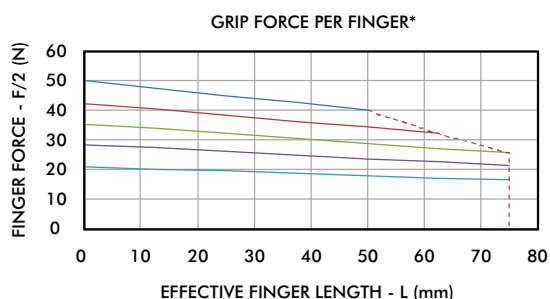
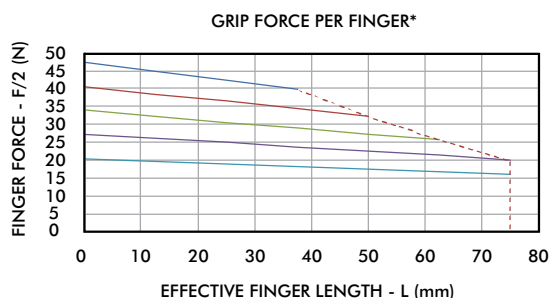
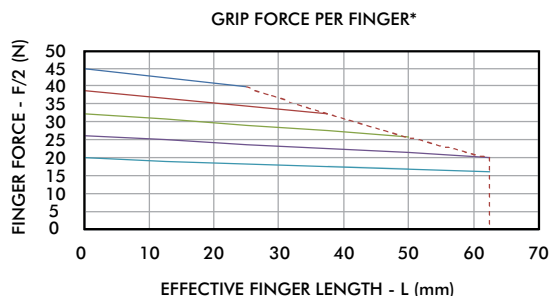
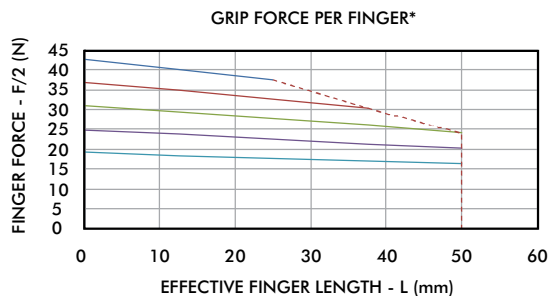

Specifications	Units	11M-05
Stroke	mm [in]	5 [0.20]
Weight	kg [lbs]	0.09 [0.20]
Displacement	cc [cu-in]	0.5 [0.03]
Actuation (open/close)	sec.	0.08
Max Tensile Load on Jaws	N [lbf]	311 [70]
Max Compressive Load on Jaws	N [lbf]	712 [160]
Max Moment on Jaws	Nm [in-lbs]	7 [60]

Specifications	Units	11M-10
Stroke	mm [in]	10 [0.39]
Weight	kg [lbs]	0.13 [0.29]
Displacement	cc [cu-in]	1.0 [0.06]
Actuation (open/close)	sec.	0.09
Max Tensile Load on Jaws	N [lbf]	350 [80]
Max Compressive Load on Jaws	N [lbf]	750 [170]
Max Moment on Jaws	Nm [in-lbs]	8 [70]

Specifications	Units	11M-15
Stroke	mm [in]	15 [0.59]
Weight	kg [lbs]	0.17 [0.37]
Displacement	cc [cu-in]	1.5 [0.09]
Actuation (open/close)	sec.	0.10
Max Tensile Load on Jaws	N [lbf]	400 [90]
Max Compressive Load on Jaws	N [lbf]	800 [180]
Max Moment on Jaws	Nm [in-lbs]	9 [80]

Specifications	Units	11M-20
Stroke	mm [in]	20 [0.79]
Weight	kg [lbs]	0.21 [0.46]
Displacement	cc [cu-in]	1.9 [0.12]
Actuation (open/close)	sec.	0.11
Max Tensile Load on Jaws	N [lbf]	445 [100]
Max Compressive Load on Jaws	N [lbf]	845 [190]
Max Moment on Jaws	Nm [in-lbs]	10 [90]

Specifications	Units	11M-25
Stroke	mm [in]	25 [0.98]
Weight	kg [lbs]	0.25 [0.55]
Displacement	cc [cu-in]	1.2 [0.15]
Actuation (open/close)	sec.	0.12
Max Tensile Load on Jaws	N [lbf]	490 [110]
Max Compressive Load on Jaws	N [lbf]	890 [200]
Max Moment on Jaws	Nm [in-lbs]	11 [100]

G110-18M

OEM Parallel Grippers | Dimensions and Technical Specifications



Specifications	Units	18M
Total Rated Grip Force	N [lbf]	260 [58]
Pressure Range	bar [psi]	3-7 [40-100]
Cylinder Bore Diameter	mm [in]	17.5 [0.69]
Temperature Range (Buna-N Seals)	°C [°F]	-35°~80° [-30°~180°]
Accuracy	mm [in]	±.05 [0.002]
Repeatability	mm [in]	±.05 [0.002]
Valve Required to Actuate		4 way 2 position

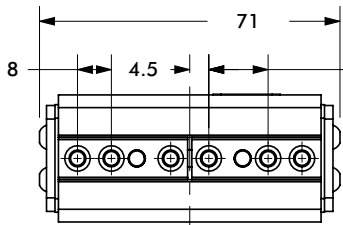
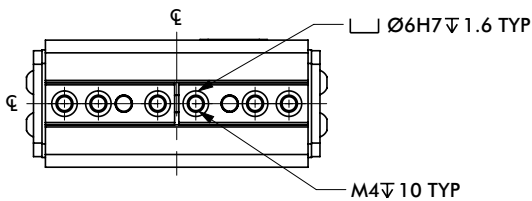
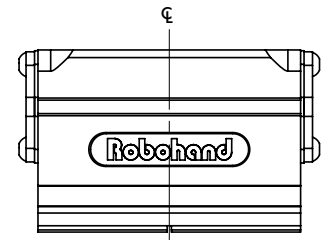
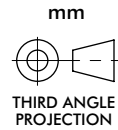
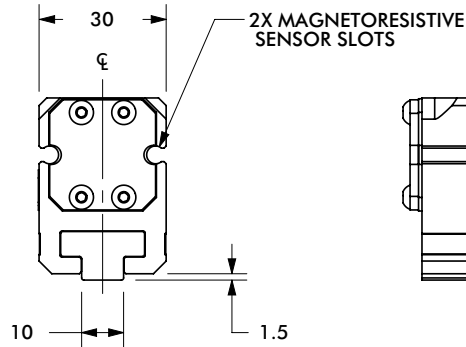
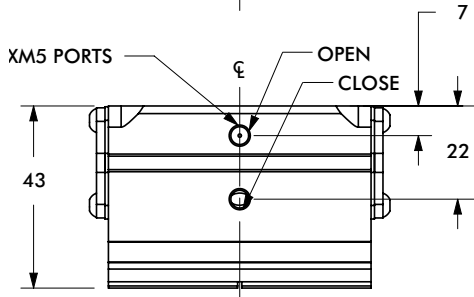
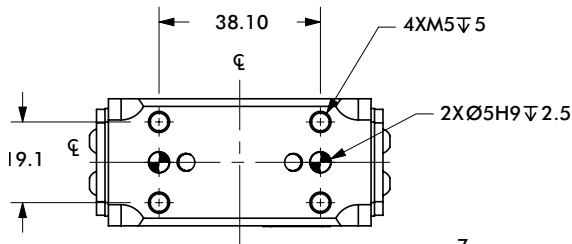

G110-18M-12

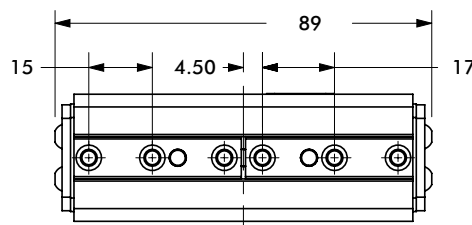

G110-18M-18

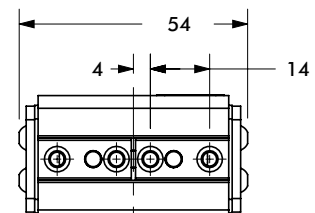

G110-18M-06

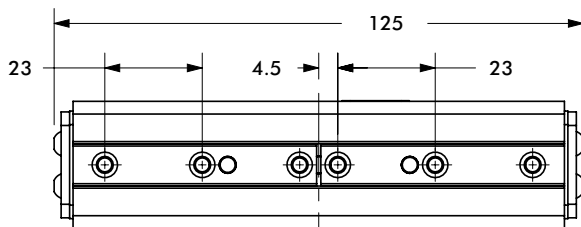

G110-18M-30

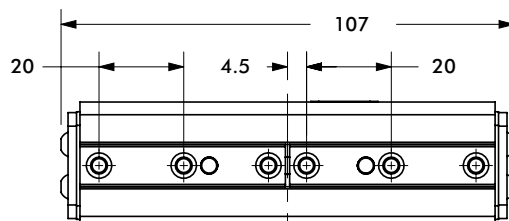

G110-18M-24

OEM Parallel Grippers | Technical Specifications

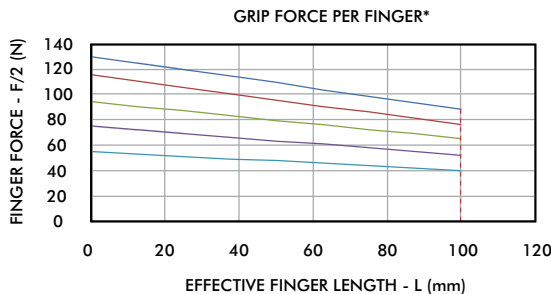
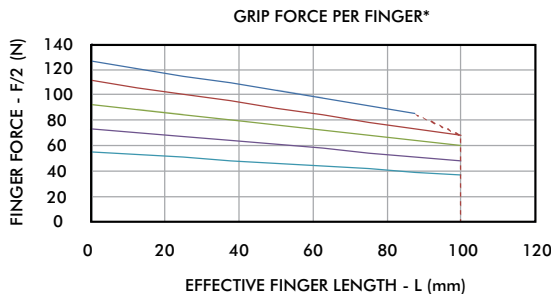
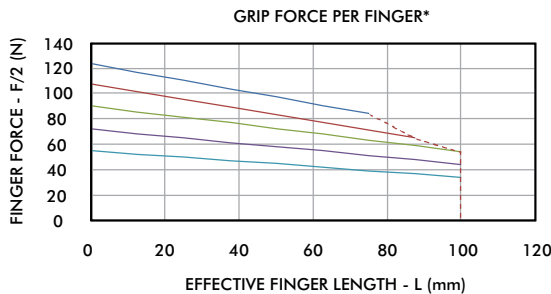
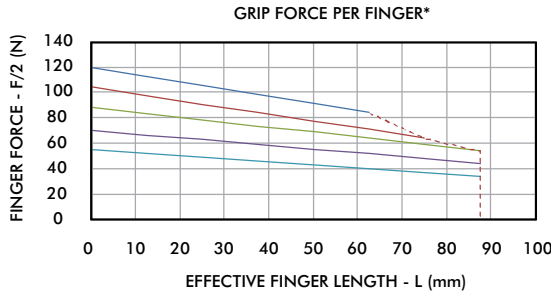
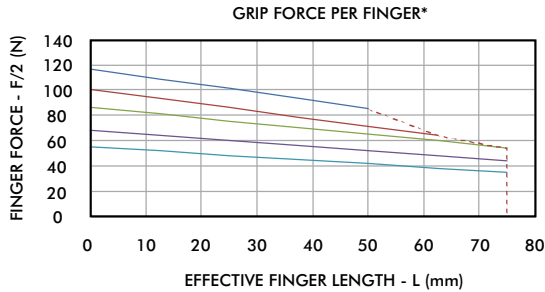

Specifications	Units	18M-06
Stroke	mm [in]	6 [0.24]
Weight	kg [lbs]	0.20 [0.44]
Displacement	cc [cu-in]	1.5 [0.09]
Actuation (open/close)	sec.	0.09
Max Tensile Load on Jaws	N [lbf]	778 [175]
Max Compressive Load on Jaws	N [lbf]	1779 [400]
Max Moment on Jaws	Nm [in-lbs]	17 [150]

Specifications	Units	18M-12
Stroke	mm [in]	12 [0.47]
Weight	kg [lbs]	0.22 [0.48]
Displacement	cc [cu-in]	2.9 [0.18]
Actuation (open/close)	sec.	0.13
Max Tensile Load on Jaws	N [lbf]	890 [200]
Max Compressive Load on Jaws	N [lbf]	1890 [425]
Max Moment on Jaws	Nm [in-lbs]	20 [175]

Specifications	Units	18M-18
Stroke	mm [in]	18 [0.71]
Weight	kg [lbs]	0.28 [0.62]
Displacement	cc [cu-in]	4.3 [0.26]
Actuation (open/close)	sec.	0.17
Max Tensile Load on Jaws	N [lbf]	1000 [225]
Max Compressive Load on Jaws	N [lbf]	2000 [450]
Max Moment on Jaws	Nm [in-lbs]	23 [200]

Specifications	Units	18M-24
Stroke	mm [in]	24 [0.94]
Weight	kg [lbs]	0.34 [0.75]
Displacement	cc [cu-in]	5.8 [0.35]
Actuation (open/close)	sec.	0.21
Max Tensile Load on Jaws	N [lbf]	1112 [250]
Max Compressive Load on Jaws	N [lbf]	2113 [475]
Max Moment on Jaws	Nm [in-lbs]	25 [225]

Specifications	Units	18M-30
Stroke	mm [in]	30 [1.18]
Weight	kg [lbs]	0.41 [0.90]
Displacement	cc [cu-in]	7.2 [0.44]
Actuation (open/close)	sec.	0.25
Max Tensile Load on Jaws	N [lbf]	1223 [275]
Max Compressive Load on Jaws	N [lbf]	2225 [500]
Max Moment on Jaws	Nm [in-lbs]	28 [250]

G110-25M

OEM Parallel Grippers | Dimensions and Technical Specifications



Specifications	Units	25M
Total Rated Grip Force	N [lbf]	558 [125]
Pressure Range	bar [psi]	3-7 [40-100]
Cylinder Bore Diameter	mm [in]	25 [1.00]
Temperature Range (Buna-N Seals)	°C [°F]	-35°~80° [-30°~180°]
Accuracy	mm [in]	±.05 [0.002]
Repeatability	mm [in]	±.05 [0.002]
Valve Required to Actuate		4 way 2 position

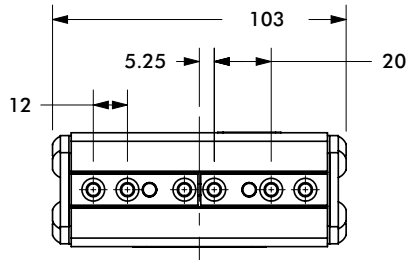
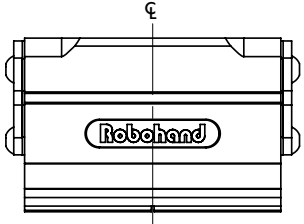
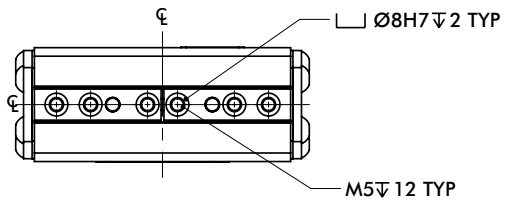
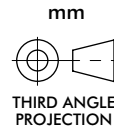
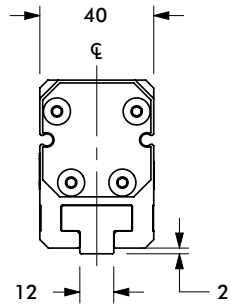
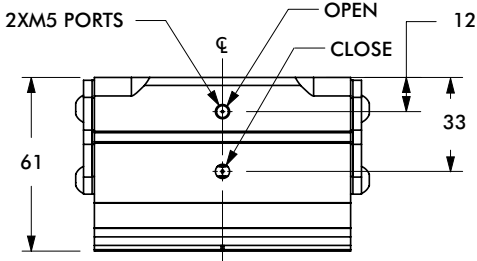
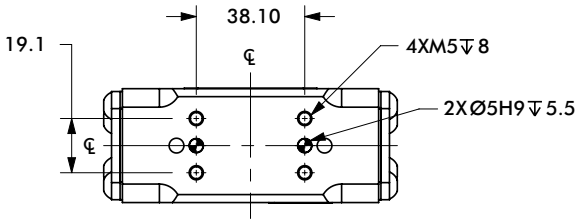

G110-25M-20

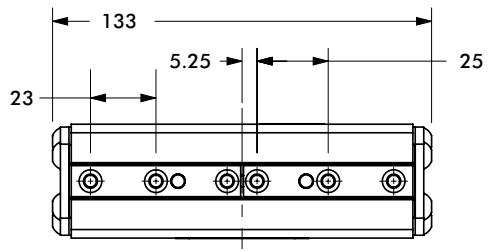

G110-25M-30

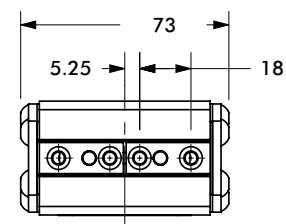

G110-25M-10

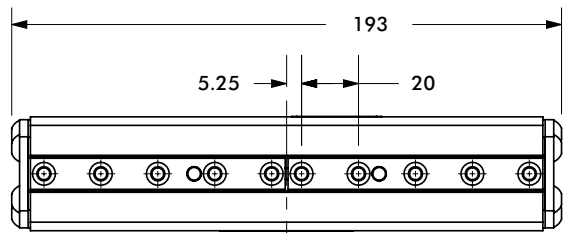

G110-25M-50

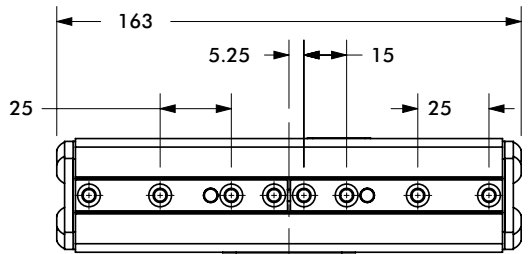

G110-25M-40

OEM Parallel Grippers | Technical Specifications

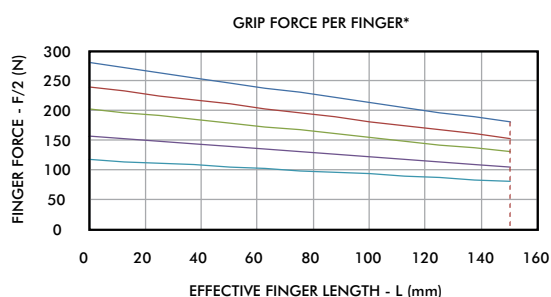
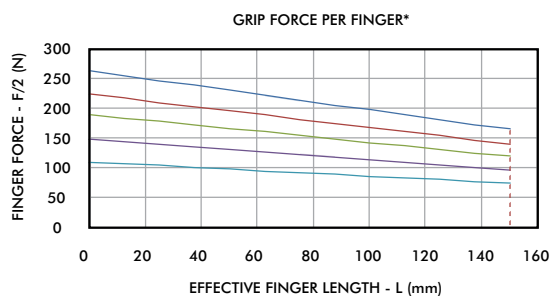
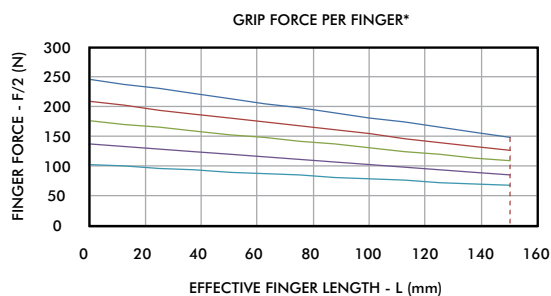
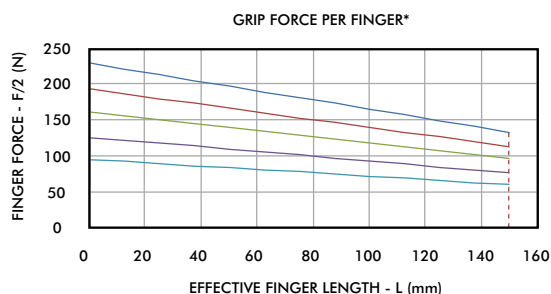
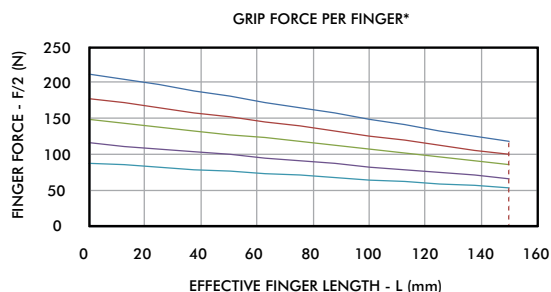

- 7 bar (102 psi)
- 6 bar (87 psi)
- 5 bar (73 psi)
- 4 bar (58 psi)
- 3 bar (44 psi)
- - - MAX FINGER LENGTH

Specifications	Units	25M-10
Stroke	mm [in]	10 [0.39]
Weight	kg [lbs]	0.42 [0.92]
Displacement	cc [cu-in]	5.06 [0.31]
Actuation (open/close)	sec.	0.28
Max Tensile Load on Jaws	N [lbf]	1550 [350]
Max Compressive Load on Jaws	N [lbf]	3550 [800]
Max Moment on Jaws	Nm [in-lbs]	35 [300]

Specifications	Units	25M-20
Stroke	mm [in]	20 [0.79]
Weight	kg [lbs]	0.64 [1.41]
Displacement	cc [cu-in]	10.12 [0.62]
Actuation (open/close)	sec.	0.36
Max Tensile Load on Jaws	N [lbf]	1750 [400]
Max Compressive Load on Jaws	N [lbf]	3775 [850]
Max Moment on Jaws	Nm [in-lbs]	40 [350]

Specifications	Units	25M-30
Stroke	mm [in]	30 [1.18]
Weight	kg [lbs]	0.85 [1.87]
Displacement	cc [cu-in]	15.19 [0.93]
Actuation (open/close)	sec.	0.44
Max Tensile Load on Jaws	N [lbf]	2000 [450]
Max Compressive Load on Jaws	N [lbf]	4000 [900]
Max Moment on Jaws	Nm [in-lbs]	45 [400]

Specifications	Units	25M-40
Stroke	mm [in]	40 [1.57]
Weight	kg [lbs]	1.03 [2.27]
Displacement	cc [cu-in]	20.3 [1.24]
Actuation (open/close)	sec.	0.52
Max Tensile Load on Jaws	N [lbf]	2225 [500]
Max Compressive Load on Jaws	N [lbf]	4225 [950]
Max Moment on Jaws	Nm [in-lbs]	50 [450]

Specifications	Units	25M-50
Stroke	mm [in]	50 [1.97]
Weight	kg [lbs]	1.22 [2.68]
Displacement	cc [cu-in]	25.31 [1.55]
Actuation (open/close)	sec.	0.61
Max Tensile Load on Jaws	N [lbf]	2450 [550]
Max Compressive Load on Jaws	N [lbf]	4450 [1000]
Max Moment on Jaws	Nm [in-lbs]	55 [500]