

RPS SERIES

2-Jaw General Industrial Parallel Grippers | Features and Benefits | How To Order

Features:

- Robust sealed design gripper
- Double wedge design for high impact applications
- Spring assist option for part retention in case of air pressure loss
- Inductive jaw location sensing
- Grip force range from 222N [50 lbs] to 2669N [600 lbs]
- Stroke Range from 6.4mm [0.25 in] to 31.8mm [1.25 in]

Applications:

- Automotive assembly
- Critical Part drop prevention applications
- General purpose spring assist gripping
- Packaging applications



U.S. Patent #5,125,708

How To Order

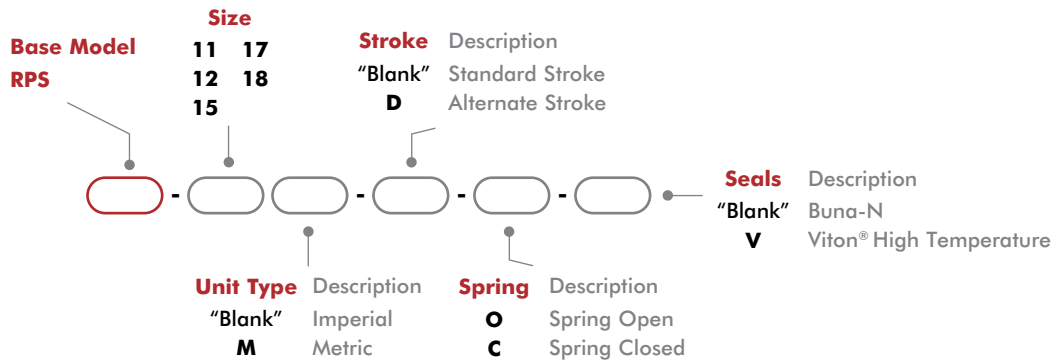

Accessories

| Sensor Accessories | Model Numbers | Part Number | Qty/Unit |
|--|---------------|-------------|----------|
| Sensor Mounting Kit for Imperial & Metric Units (mounts 2 sensors) | See Datasheet | | 1 |
| NPN Inductive Sensor with Quick Disconnect* | 11, 12, 15 | OISN-019 | 1-2 |
| PNP Inductive Sensor with Quick Disconnect* | 11, 12, 15 | OISP-019 | 1-2 |
| NPN Inductive Sensor with Quick Disconnect* | 17, 18 | OISN-011 | 1-2 |
| PNP Inductive Sensor with Quick Disconnect* | 17, 18 | OISP-011 | 1-2 |
| Quick Disconnect 2 Meter Cable Length* | All Models | CABL-010 | 1-2 |
| Quick Disconnect 5 Meter Cable Length* | All Models | CABL-013 | 1-2 |

| Pneumatic Accessories | Model Numbers | Part Number | Qty/Unit |
|----------------------------|---------------|-------------|----------|
| Fail Safe Valve (Imperial) | See Datasheet | | 1 |
| Fail Safe Valve (Metric) | See Datasheet | | 1 |

*Sensor and cable sold separately.

2-Jaw General Industrial Parallel Grippers | Technical Specifications

| Specifications | Units | 11 | 11-D | 12 | 12-D | 15 | 15-D |
|---|------------------------------------|-----------------------|----------|-------------|----------|-------------|-----------|
| Total Rated Grip Force F @ 100 psi [7 bar] | N [lbs] | 222 [50] | 378 [85] | 267 [60] | 400 [90] | 400 [90] | 110 [489] |
| Total Stroke | mm [in] | 6.4 [0.25] | 4 [0.16] | 9.5 [0.38] | 6 [0.24] | 12.7 [0.50] | 8 [0.31] |
| Weight | kg [lbs] | 0.16 [0.36] | | 0.34 [0.76] | | 0.65 [1.44] | |
| Pressure Range | bar [psi] | 3.4-7 [50-100] | | | | | |
| Ingress Protection Class (IP) | | IP43 | | | | | |
| Displacement | cm ³ [in ³] | 1.6 [0.098] | | 2.5 [0.150] | | 4.9 [0.300] | |
| Temperature Range (Buna-N seals) | °C [°F] | -35°~80° [-30°~180°] | | | | | |
| Temperature Range (Viton® seals) | °C [°F] | -30°~150° [-20°~300°] | | | | | |
| Actuation | sec | 0.15 | | | | 0.17 | |
| Accuracy | mm [in] | ±0.05 [±0.002] | | | | | |
| Repeatability | mm [in] | ±0.03 [±0.001] | | | | | |
| Valve to Required Actuate Single Acting | | 3-way, 2-position | | | | | |
| Valve to Required Actuate Double Acting | | 4-way, 2-position | | | | | |

| Specifications | Units | 17 | 17-D | 18 | 18-D |
|---|------------------------------------|-----------------------|-----------|--------------|------------|
| Total Rated Grip Force F @ 100 psi [7 bar] | N [lbs] | 1334 [300] | 180 [800] | 2669 [600] | 380 [1690] |
| Total Stroke | mm [in] | 19.1 [0.75] | 28 [1.10] | 31.8 [1.25] | 43 [1.70] |
| Weight | kg [lbs] | 1.4 [3.00] | | 5.0 [11.02] | |
| Pressure Range | bar [psi] | 3-7 [40-100] | | | |
| Ingress Protection Class (IP) | | IP43 | | | |
| Displacement | cm ³ [in ³] | 22.9 [1.400] | | 72.1 [4.400] | |
| Temperature Range (Buna-N seals) | °C [°F] | -35°~80° [-30°~180°] | | | |
| Temperature Range (Viton® seals) | °C [°F] | -30°~150° [-20°~300°] | | | |
| Actuation | sec | 0.31 | | 0.51 | |
| Accuracy | mm [in] | ±0.08 [±0.003] | | | |
| Repeatability | mm [in] | ±0.03 [±0.001] | | | |
| Valve to Required Actuate Single Acting | | 3-way, 2-position | | | |
| Valve to Required Actuate Double Acting | | 4-way, 2-position | | | |

RPS-11

2-Jaw General Industrial Parallel Grippers | Dimensions and Technical Specifications

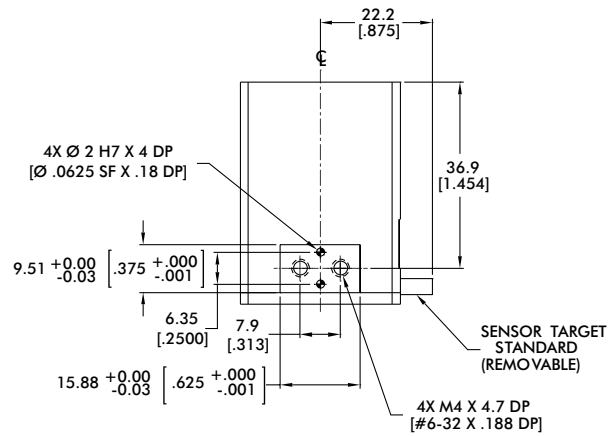
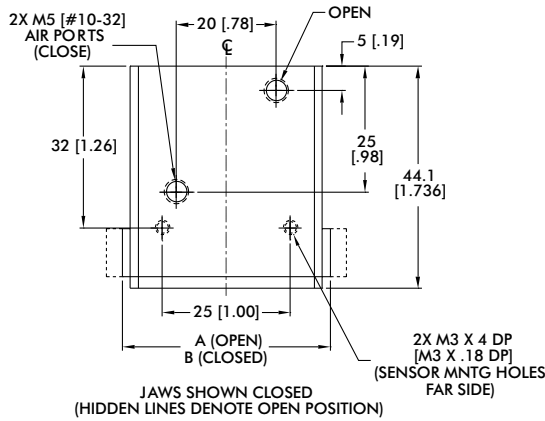
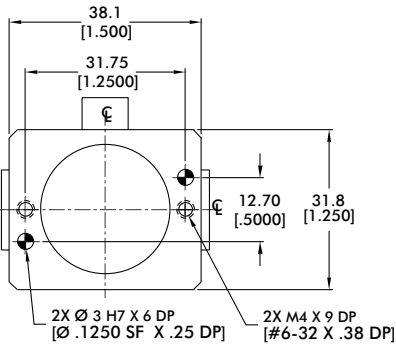

| Sensor Accessories | RPS-11 |
|--|----------|
| Inductive Sensor Mounting Kit (mounts 2 sensors) | OSMK-003 |

| Seal Repair Kits | RPS-11 |
|------------------------|-----------|
| Buna-N Seal Repair Kit | SLKT-036 |
| Viton® Seal Repair Kit | SLKT-036V |

| Pneumatic Accessories | RPS-11 |
|----------------------------|----------|
| Fail Safe Valve (Imperial) | OFSV-001 |
| Fail Safe Valve (Metric) | OFSV-004 |

| Model | A | B |
|----------|-----------|-----------|
| RPS-11 | 48 [1.88] | 41 [1.63] |
| RPS-11-D | 45 [1.79] | |

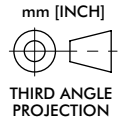

Loading Information

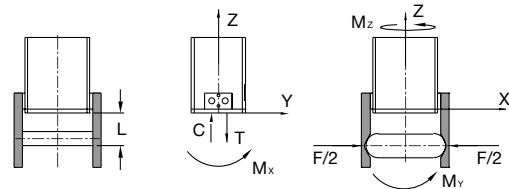
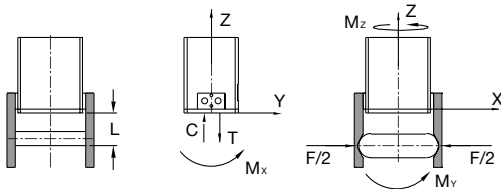
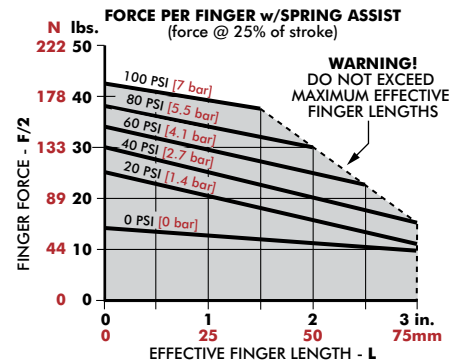
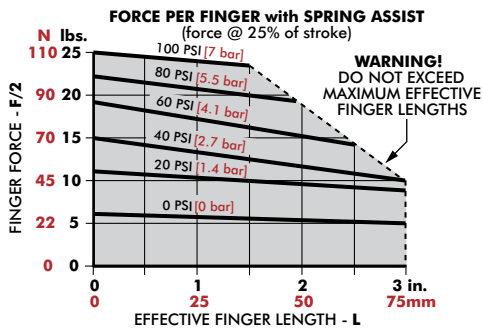

| RPS-11 | Static | Dynamic |
|-------------------------------------|--------------------|------------------|
| Maximum Tensile T | 445 N [100 lbs] | 111 N [25 lbs] |
| Maximum Compressive C | 890 N [200 lbs] | 111 N [25 lbs] |
| Maximum Moment M_x | 11 Nm [100 in-lbs] | 3 Nm [25 in-lbs] |
| Maximum Moment M_y | 11 Nm [100 in-lbs] | 3 Nm [25 in-lbs] |
| Maximum Moment M_z | 11 Nm [100 in-lbs] | 3 Nm [25 in-lbs] |

*Capacities are per set of jaws and are not simultaneous

| RPS-11-D | Static | Dynamic |
|-------------------------------------|--------------------|------------------|
| Maximum Tensile T | 445 N [100 lbs] | 111 N [25 lbs] |
| Maximum Compressive C | 890 N [200 lbs] | 111 N [25 lbs] |
| Maximum Moment M_x | 11 Nm [100 in-lbs] | 3 Nm [25 in-lbs] |
| Maximum Moment M_y | 11 Nm [100 in-lbs] | 3 Nm [25 in-lbs] |
| Maximum Moment M_z | 11 Nm [100 in-lbs] | 3 Nm [25 in-lbs] |

*Capacities are per set of jaws and are not simultaneous

2-Jaw General Industrial Parallel Grippers | Dimensions and Technical Specifications

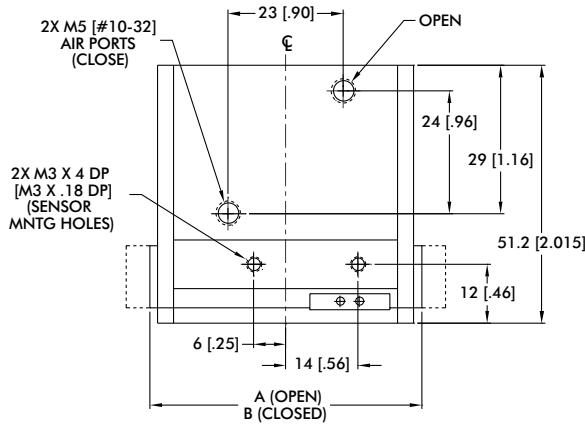
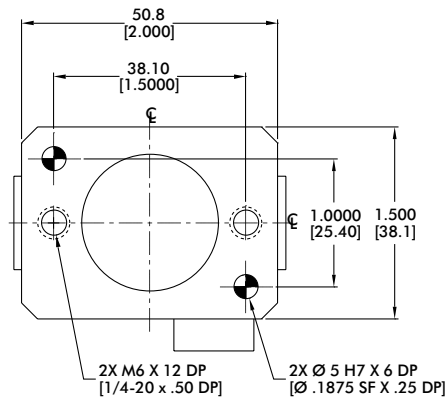

JAWS SHOWN IN CLOSED POSITION
(HIDDEN LINES DENOTE OPEN POSITION)

| Sensor Accessories | RPS-12 |
|--|----------|
| Inductive Sensor Mounting Kit (mounts 2 sensors) | OSMK-003 |

| Seal Repair Kits | RPS-12 |
|------------------------|-----------|
| Buna-N Seal Repair Kit | SLKT-040 |
| Viton® Seal Repair Kit | SLKT-040V |

| Pneumatic Accessories | RPS-12 |
|----------------------------|----------|
| Fail Safe Valve (Imperial) | OFSV-001 |
| Fail Safe Valve (Metric) | OFSV-004 |

| Model | A | B |
|----------|-----------|-----------|
| RPS-12 | 63 [2.50] | 54 [2.13] |
| RPS-12-D | 60 [2.37] | |

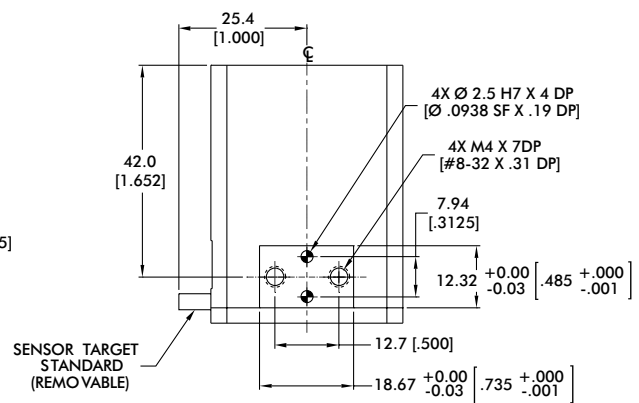
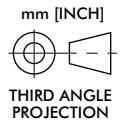

Loading Information

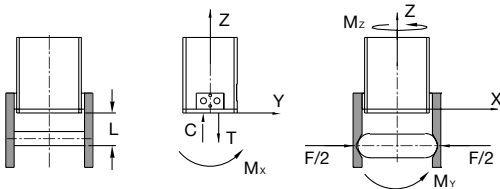
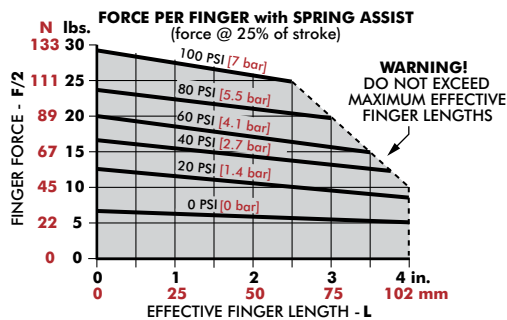

| RPS-12 | Static | Dynamic |
|-------------------------------------|--------------------|------------------|
| Maximum Tensile T | 890 N [200 lbs] | 222 N [50 lbs] |
| Maximum Compressive C | 1779 N [400 lbs] | 222 N [50 lbs] |
| Maximum Moment M_x | 17 Nm [150 in-lbs] | 6 Nm [50 in-lbs] |
| Maximum Moment M_y | 17 Nm [150 in-lbs] | 6 Nm [50 in-lbs] |
| Maximum Moment M_z | 17 Nm [150 in-lbs] | 6 Nm [50 in-lbs] |

*Capacities are per set of jaws and are not simultaneous

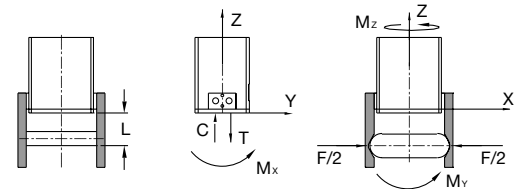
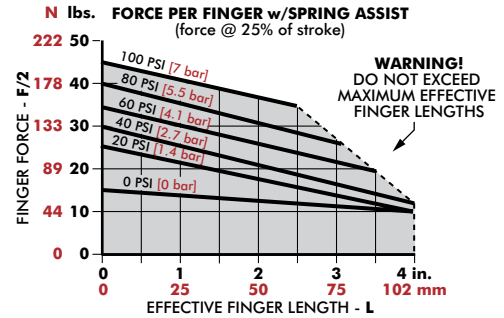

| RPS-12-D | Static | Dynamic |
|-------------------------------------|--------------------|------------------|
| Maximum Tensile T | 890 N [200 lbs] | 222 N [50 lbs] |
| Maximum Compressive C | 1779 N [400 lbs] | 222 N [50 lbs] |
| Maximum Moment M_x | 17 Nm [150 in-lbs] | 6 Nm [50 in-lbs] |
| Maximum Moment M_y | 17 Nm [150 in-lbs] | 6 Nm [50 in-lbs] |
| Maximum Moment M_z | 17 Nm [150 in-lbs] | 6 Nm [50 in-lbs] |

*Capacities are per set of jaws and are not simultaneous

RPS-15

2-Jaw General Industrial Parallel Grippers | Dimensions and Technical Specifications

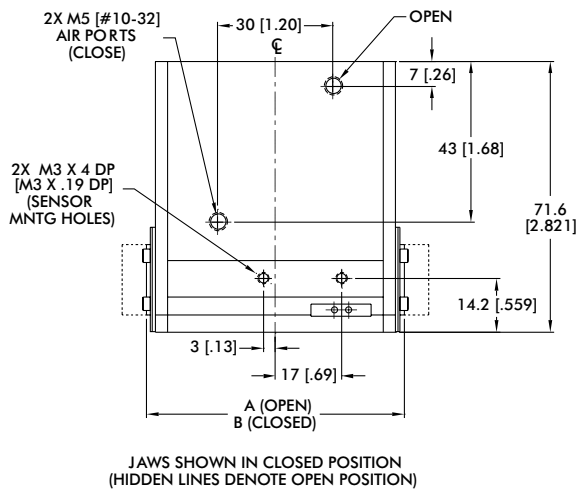
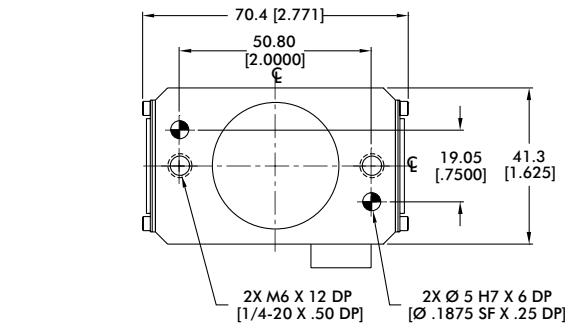

JAWS SHOWN IN CLOSED POSITION
(HIDDEN LINES DENOTE OPEN POSITION)

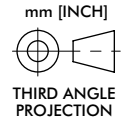
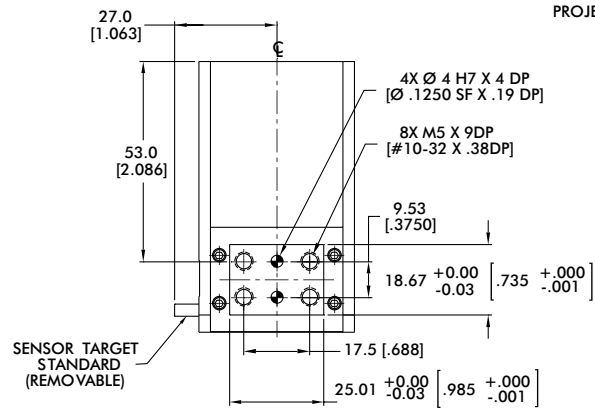

| Sensor Accessories | RPS-15 |
|--|----------|
| Inductive Sensor Mounting Kit (mounts 2 sensors) | OSMK-003 |

| Seal Repair Kits | RPS-15 |
|------------------------|-----------|
| Buna-N Seal Repair Kit | SLKT-041 |
| Viton® Seal Repair Kit | SLKT-041V |

| Pneumatic Accessories | RPS-15 |
|----------------------------|----------|
| Fail Safe Valve (Imperial) | OFSV-001 |
| Fail Safe Valve (Metric) | OFSV-004 |

| Model | A | B |
|----------|-----------|-----------|
| RPS-15 | 81 [3.19] | 68 [2.69] |
| RPS-15-D | 76 [3.00] | |

Loading Information

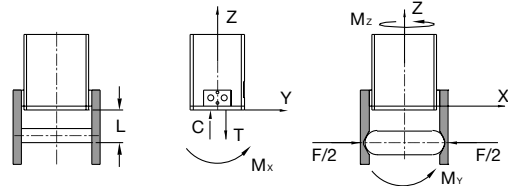
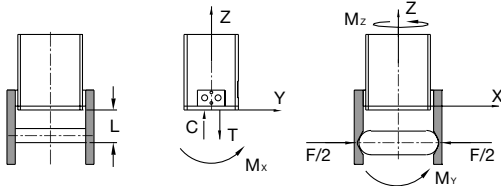
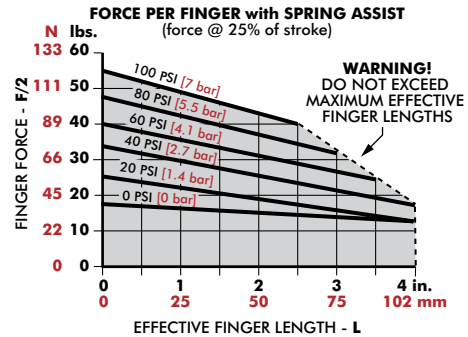
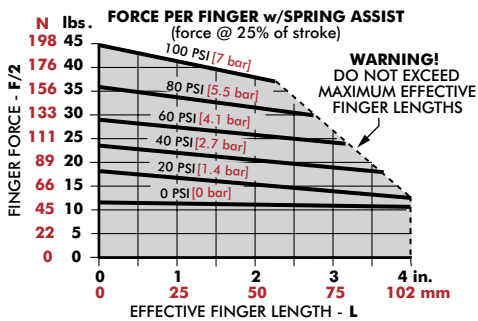

| RPS-15 | Static | Dynamic |
|-------------------------------------|--------------------|--------------------|
| Maximum Tensile T | 1779 N [400 lbs] | 445 N [100 lbs] |
| Maximum Compressive C | 3336 N [750 lbs] | 445 N [100 lbs] |
| Maximum Moment M_x | 34 Nm [300 in-lbs] | 11 Nm [100 in-lbs] |
| Maximum Moment M_y | 34 Nm [300 in-lbs] | 11 Nm [100 in-lbs] |
| Maximum Moment M_z | 34 Nm [300 in-lbs] | 11 Nm [100 in-lbs] |

*Capacities are per set of jaws and are not simultaneous

| RPS-15-D | Static | Dynamic |
|-------------------------------------|--------------------|--------------------|
| Maximum Tensile T | 1779 N [400 lbs] | 445 N [100 lbs] |
| Maximum Compressive C | 3336 N [750 lbs] | 445 N [100 lbs] |
| Maximum Moment M_x | 34 Nm [300 in-lbs] | 11 Nm [100 in-lbs] |
| Maximum Moment M_y | 34 Nm [300 in-lbs] | 11 Nm [100 in-lbs] |
| Maximum Moment M_z | 34 Nm [300 in-lbs] | 11 Nm [100 in-lbs] |

*Capacities are per set of jaws and are not simultaneous

2-Jaw General Industrial Parallel Grippers | Dimensions and Technical Specifications

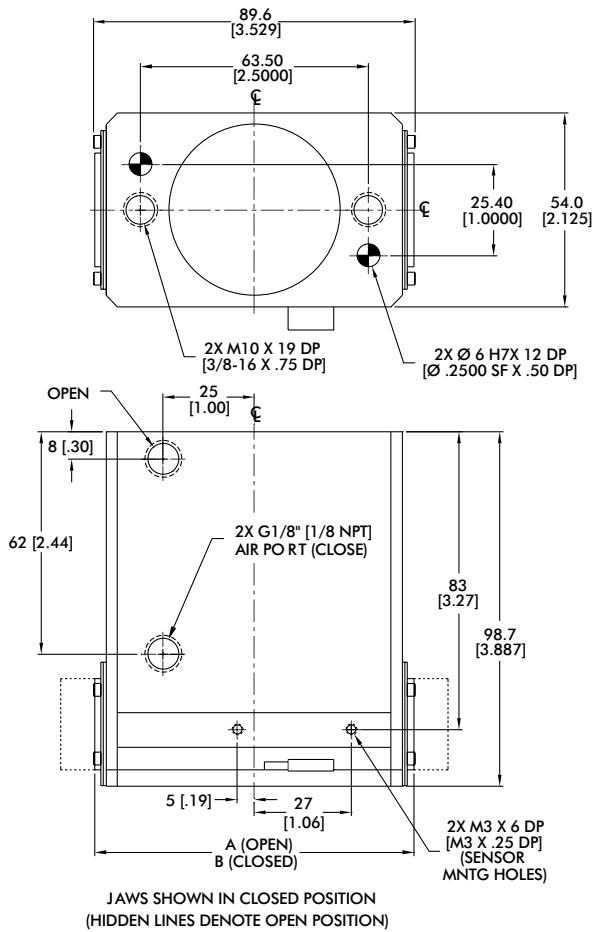

| Sensor Accessories | RPS-17 |
|--|----------|
| Inductive Sensor Mounting Kit (mounts 2 sensors) | OSMK-072 |

| Seal Repair Kits | RPS-17 |
|------------------------|-----------|
| Buna-N Seal Repair Kit | SLKT-042 |
| Viton® Seal Repair Kit | SLKT-042V |

| Pneumatic Accessories | RPS-17 |
|----------------------------|----------|
| Fail Safe Valve (Imperial) | OFSV-002 |
| Fail Safe Valve (Metric) | OFSV-005 |

| Model | A | B |
|----------|------------|-----------|
| RPS-17 | 107 [4.25] | 89 [3.50] |
| RPS-17-D | 117 [4.60] | |

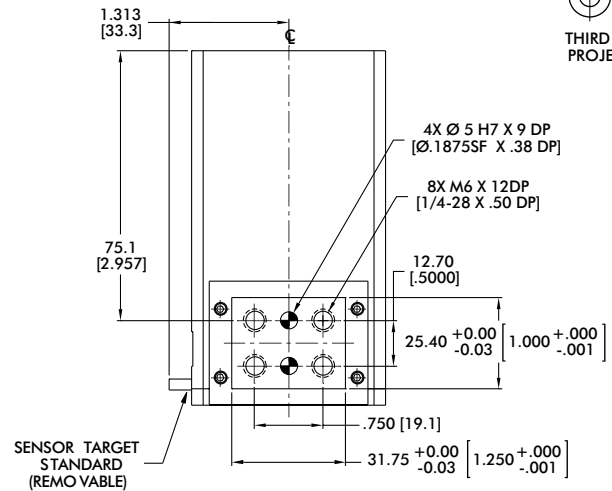
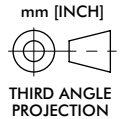

Loading Information

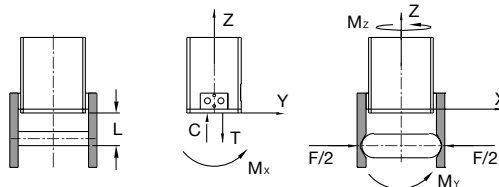
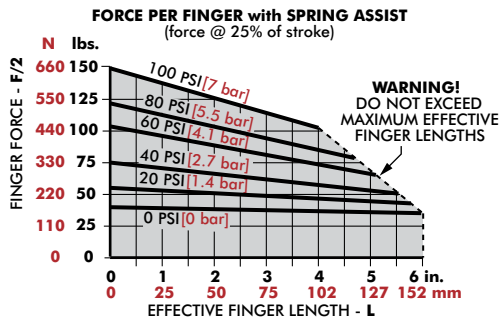

| RPS-17 | Static | Dynamic |
|-------------------------------------|--------------------|--------------------|
| Maximum Tensile T | 3336 N [750 lbs] | 890 N [200 lbs] |
| Maximum Compressive C | 6672 N [1500 lbs] | 890 N [200 lbs] |
| Maximum Moment M_x | 85 Nm [750 in-lbs] | 28 Nm [250 in-lbs] |
| Maximum Moment M_y | 85 Nm [750 in-lbs] | 28 Nm [250 in-lbs] |
| Maximum Moment M_x | 85 Nm [750 in-lbs] | 28 Nm [250 in-lbs] |

¹Capacities are per set of jaws and are not simultaneous

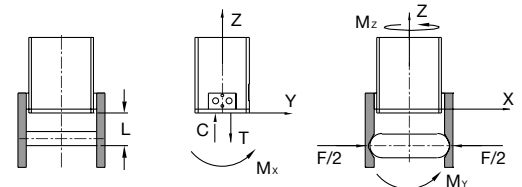
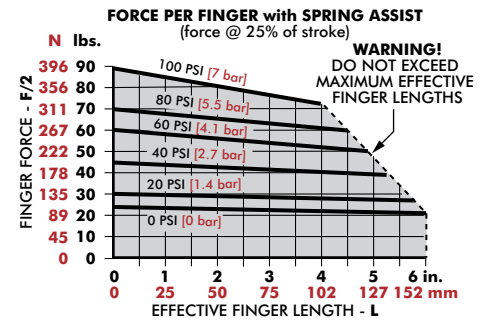

| RPS-17-D | Static | Dynamic |
|-------------------------------------|--------------------|--------------------|
| Maximum Tensile T | 3336 N [750 lbs] | 890 N [200 lbs] |
| Maximum Compressive C | 6672 N [1500 lbs] | 890 N [200 lbs] |
| Maximum Moment M_x | 85 Nm [750 in-lbs] | 28 Nm [250 in-lbs] |
| Maximum Moment M_y | 85 Nm [750 in-lbs] | 28 Nm [250 in-lbs] |
| Maximum Moment M_x | 85 Nm [750 in-lbs] | 28 Nm [250 in-lbs] |

¹Capacities are per set of jaws and are not simultaneous

RPS-18

2-Jaw General Industrial Parallel Grippers | Dimensions and Technical Specifications

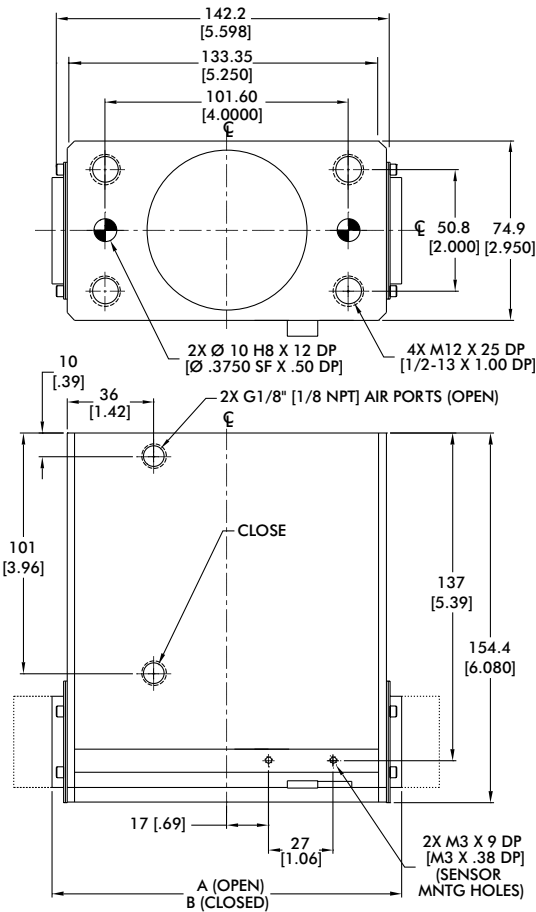

JA WS SHOWN IN CLOSED POSITION
(HIDDEN LINES DENOTE OPEN POSITION)

| Sensor Accessories | RPS-18 |
|--|----------|
| Inductive Sensor Mounting Kit (mounts 2 sensors) | OSMK-072 |

| Seal Repair Kits | RPS-18 |
|------------------------|-----------|
| Buna-N Seal Repair Kit | SLKT-043 |
| Viton® Seal Repair Kit | SLKT-043V |

| Pneumatic Accessories | RPS-18 |
|----------------------------|----------|
| Fail Safe Valve (Imperial) | OFSV-002 |
| Fail Safe Valve (Metric) | OFSV-005 |

| Model | A | B |
|----------|------------|------------|
| RPS-18 | 177 [7.00] | 146 [5.75] |
| RPS-18-D | 190 [7.45] | 146 [5.75] |

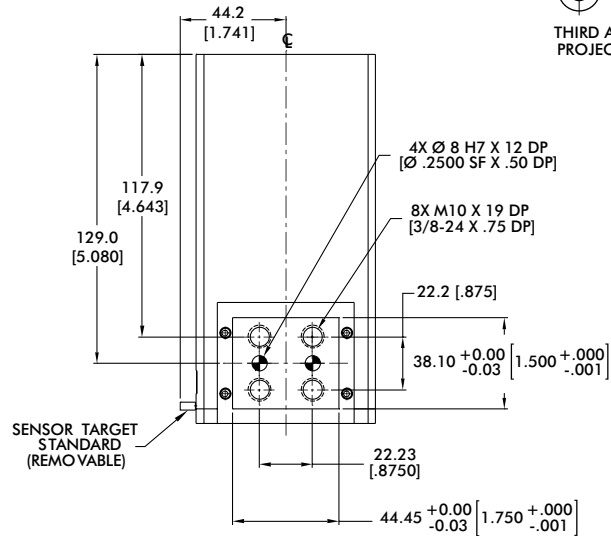
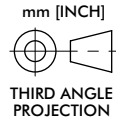

Loading Information

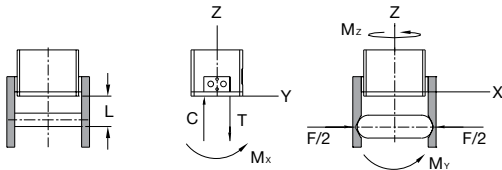
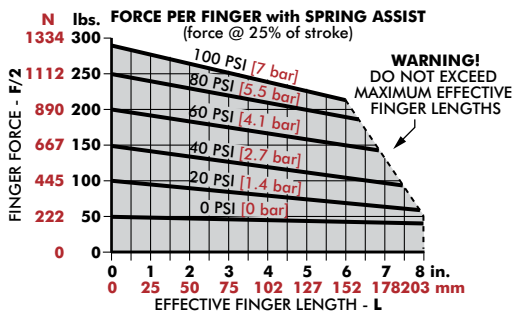

| RPS-18 | Static | Dynamic |
|-------------------------------------|----------------------|--------------------|
| Maximum Tensile T | 6672 N [1500 lbs] | 2224 N [500 lbs] |
| Maximum Compressive C | 13345 N [3000 lbs] | 2224 N [500 lbs] |
| Maximum Moment M_x | 170 Nm [1500 in-lbs] | 57 Nm [500 in-lbs] |
| Maximum Moment M_y | 170 Nm [1500 in-lbs] | 57 Nm [500 in-lbs] |
| Maximum Moment M_z | 170 Nm [1500 in-lbs] | 57 Nm [500 in-lbs] |

*Capacities are per set of jaws and are not simultaneous

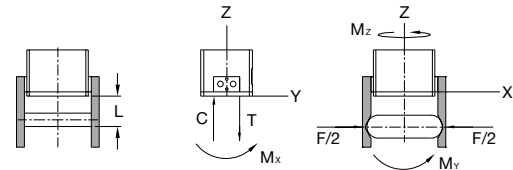
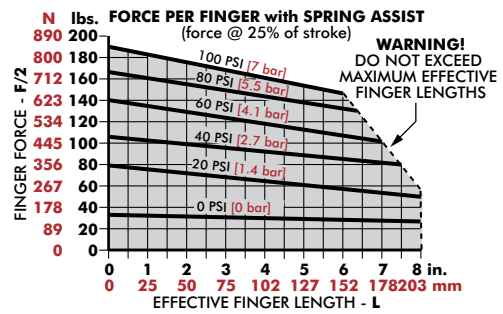

| RPS-18-D | Static | Dynamic |
|-------------------------------------|----------------------|--------------------|
| Maximum Tensile T | 6672 N [1500 lbs] | 2224 N [500 lbs] |
| Maximum Compressive C | 13345 N [3000 lbs] | 2224 N [500 lbs] |
| Maximum Moment M_x | 170 Nm [1500 in-lbs] | 57 Nm [500 in-lbs] |
| Maximum Moment M_y | 170 Nm [1500 in-lbs] | 57 Nm [500 in-lbs] |
| Maximum Moment M_z | 170 Nm [1500 in-lbs] | 57 Nm [500 in-lbs] |

*Capacities are per set of jaws and are not simultaneous

