

# RP SERIES

## 2-Jaw General Industrial Parallel Grippers | Features and Benefits | How To Order

### Features:

- Widely used robust sealed design gripper
- Double wedge design for high impact applications
- Hardened steel bottom for part pressing applications
- Inductive jaw location sensing
- Grip force range from 178N [40 lbs] to 2669N [600 lbs]
- Stroke Range from 6.4mm [0.25 in] to 50.8mm [2.00 in]

### Applications:

- Inline part pressing applications
- OEM machine pick and place
- Packaging applications
- Automotive assembly

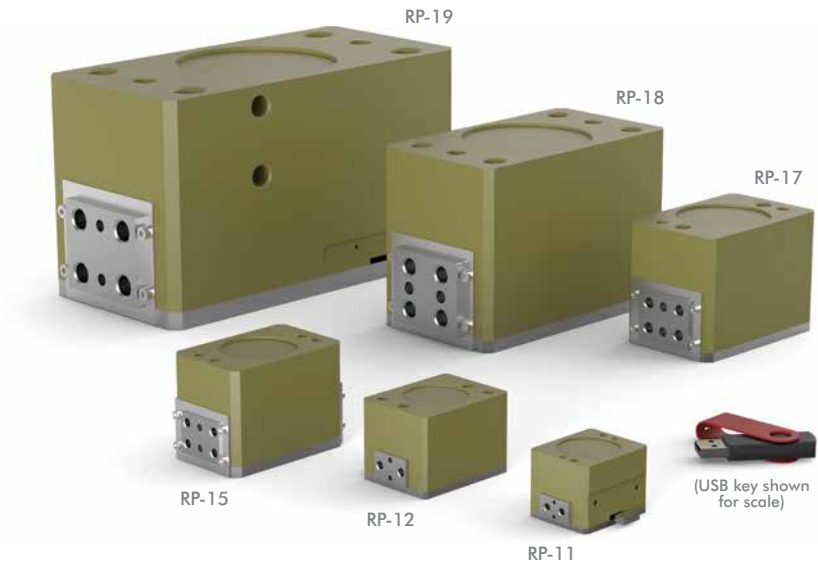

U.S. Patent #5,125,708

## How To Order

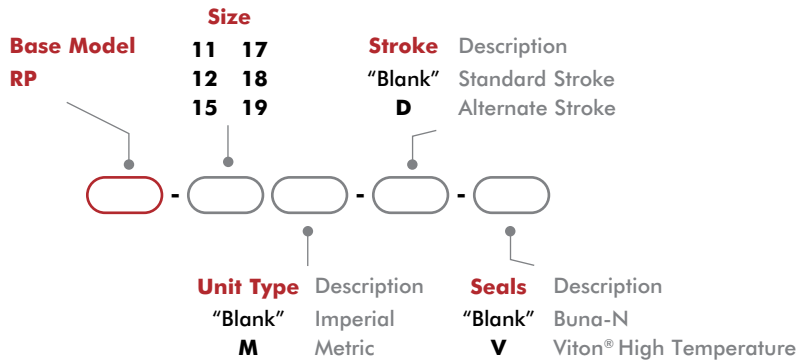

## Accessories

Sensor Accessories	Model Numbers	Part Number	Qty/Unit
Sensor Mounting Kit for Imperial & Metric Units (mounts 2 sensors)	See Datasheet		1
NPN Inductive Sensor with Quick Disconnect*	11, 12, 15	OISN-019	1-2
PNP Inductive Sensor with Quick Disconnect*	11, 12, 15	OISP-019	1-2
NPN Inductive Sensor with Quick Disconnect*	17, 18, 19	OISN-011	1-2
PNP Inductive Sensor with Quick Disconnect*	17, 18, 19	OISP-011	1-2
Quick Disconnect 2 Meter Cable Length*	All Models	CABL-010	1-2
Quick Disconnect 5 Meter Cable Length*	All Models	CABL-013	1-2

Pneumatic Accessories	Model Numbers	Part Number	Qty/Unit
Fail Safe Valve (Imperial)	See Datasheet		1
Fail Safe Valve (Metric)	See Datasheet		1

\* Sensor and cable sold separately.

## 2-Jaw General Industrial Parallel Grippers | Technical Specifications

Specifications	Units	11	11-D	12	12-D	15	15-D
Total Rated Grip Force <b>F</b> @ 100 psi [7 bar]	N [lbs]	178 [40]	312 [70]	178 [40]	267 [60]	310 [70]	445 [100]
Total Stroke	mm [in]	6.4 [0.25]	4 [0.16]	9.5 [0.38]	6 [0.24]	12.7 [0.50]	8 [0.31]
Weight	kg [lbs]	0.12 [0.26]		0.25 [0.56]		0.57 [1.25]	
Pressure Range	bar [psi]	3-7 [40-100]					
Ingress Protection Class (IP)		IP43					
Displacement	cm <sup>3</sup> [in <sup>3</sup> ]	1.6 [0.098]		2.5 [0.150]		4.9 [0.300]	
Temperature Range (Buna-N seals)	°C [°F]	-35°~80° [-30°~180°]					
Temperature Range (Viton® seals)	°C [°F]	-30°~150° [-20°~300°]					
Actuation	sec	0.13				0.20	
Accuracy	mm [in]	±0.05 [±0.002]					
Repeatability	mm [in]	±0.03 [±0.001]					
Valve to Actuate		4-way, 2-position					

Specifications	Units	17	17-D	18	18-D	19	19-D
Total Rated Grip Force <b>F</b> @ 100 psi [7 bar]	N [lbs]	979 [220]	578 [130]	1779 [400]	1112 [250]	2669 [600]	3336 [750]
Total Stroke	mm [in]	19.1 [0.75]	28 [1.10]	31.8 [1.25]	43 [1.70]	50.8 [2.00]	38.1 [1.50]
Weight	kg [lbs]	1.0 [2.2]		3.5 [7.7]		9.5 [21]	
Pressure Range	bar [psi]	3-7 [40-100]					
Ingress Protection Class (IP)		IP43					
Displacement	cm <sup>3</sup> [in <sup>3</sup> ]	22.9 [1.400]		72.1 [4.400]		157.3 [9.600]	
Temperature Range (Buna-N seals)	°C [°F]	-35°~80° [-30°~180°]					
Temperature Range (Viton® seals)	°C [°F]	-30°~150° [-20°~300°]					
Actuation	sec	0.18		0.22		0.50	
Accuracy	mm [in]	±0.08 [±0.003]					
Repeatability	mm [in]	±0.03 [±0.001]					
Valve to Actuate		4-way, 2-position					

# RP-11

## 2-Jaw General Industrial Parallel Grippers | Dimensions and Technical Specifications

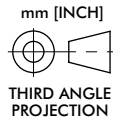
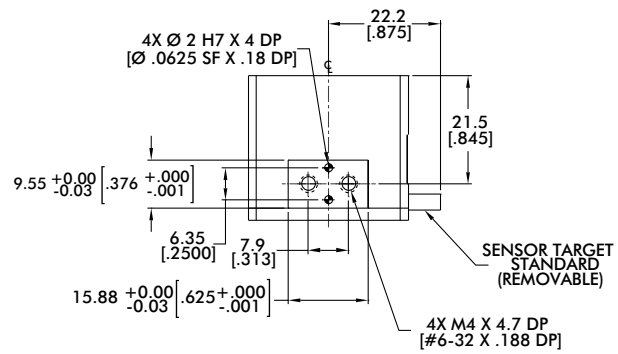
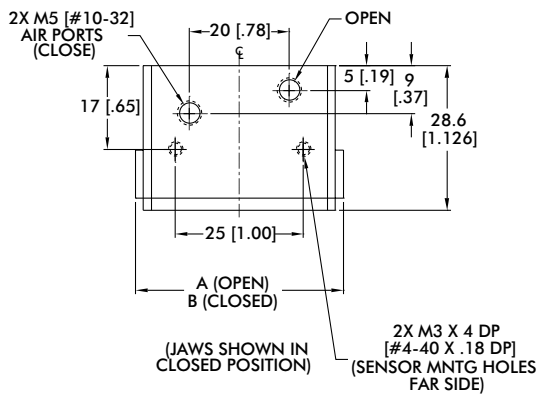
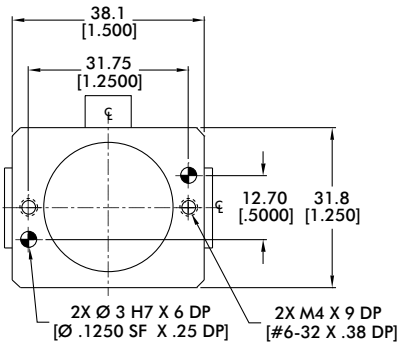

Model	A	B
RP-11	48 [1.88]	41 [1.63]
RP-11-D	45 [1.79]	

### Loading Information

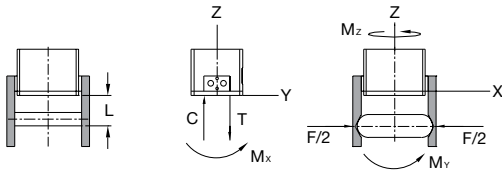
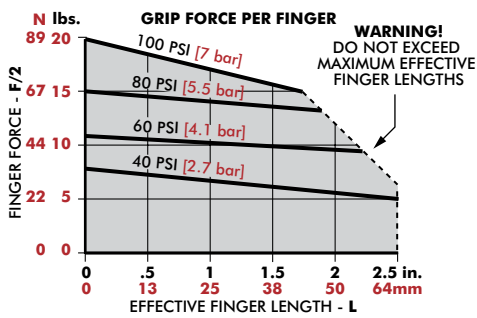

RP-11	Static	Dynamic
Maximum Tensile <b>T</b>	445 N [100 lbs]	111 N [25 lbs]
Maximum Compressive <b>C</b>	890 N [200 lbs]	111 N [25 lbs]
Maximum Moment <b>M<sub>x</sub></b>	11 Nm [100 in-lbs]	2 Nm [17 in-lbs]
Maximum Moment <b>M<sub>y</sub></b>	11 Nm [100 in-lbs]	2 Nm [17 in-lbs]
Maximum Moment <b>M<sub>z</sub></b>	11 Nm [100 in-lbs]	2 Nm [17 in-lbs]

\*Capacities are per set of jaws and are not simultaneous

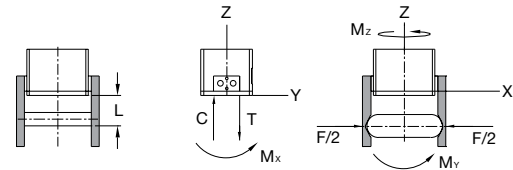
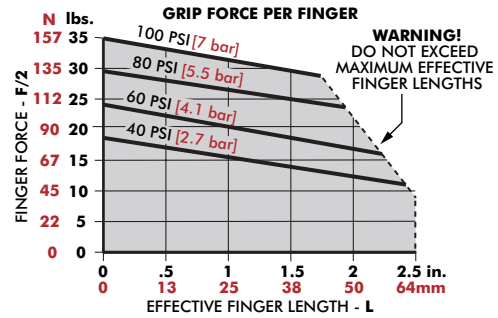

RP-11-D	Static	Dynamic
Maximum Tensile <b>T</b>	445 N [100 lbs]	111 N [25 lbs]
Maximum Compressive <b>C</b>	890 N [200 lbs]	111 N [25 lbs]
Maximum Moment <b>M<sub>x</sub></b>	11 Nm [100 in-lbs]	2 Nm [17 in-lbs]
Maximum Moment <b>M<sub>y</sub></b>	11 Nm [100 in-lbs]	2 Nm [17 in-lbs]
Maximum Moment <b>M<sub>z</sub></b>	11 Nm [100 in-lbs]	2 Nm [17 in-lbs]

\*Capacities are per set of jaws and are not simultaneous

## 2-Jaw General Industrial Parallel Grippers | Dimensions and Technical Specifications

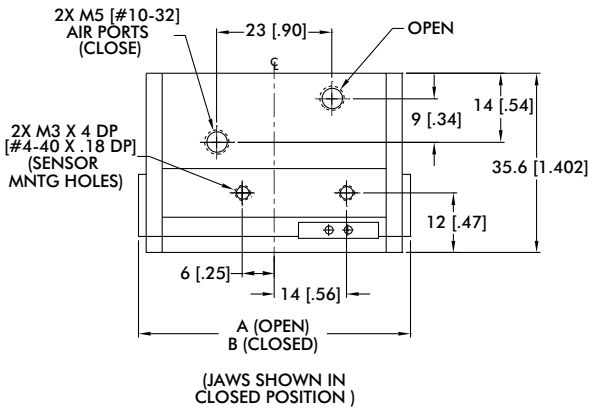
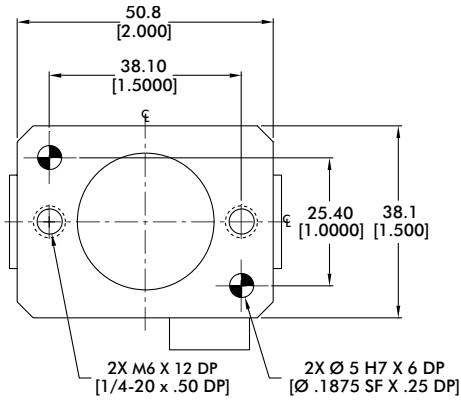

Model	A	B
RP-12	63 [2.50]	54 [2.13]
RP-12-D	60 [2.37]	

Sensor Accessories	RP-12
Inductive Sensor Mounting Kit (mounts 2 sensors)	OSMK-003

Seal Repair Kits	RP-12
Buna-N Seal Repair Kit	SLKT-040
Viton® Seal Repair Kit	SLKT-040V

Pneumatic Accessories	RP-12
Fail Safe Valve (Imperial)	OFSV-001
Fail Safe Valve (Metric)	OFSV-004

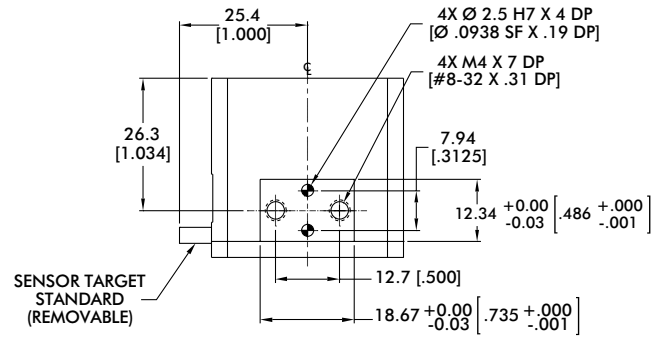

## Loading Information

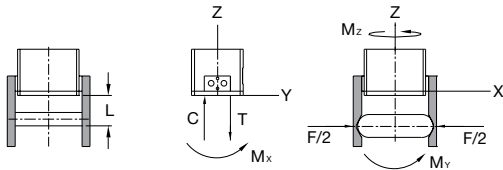
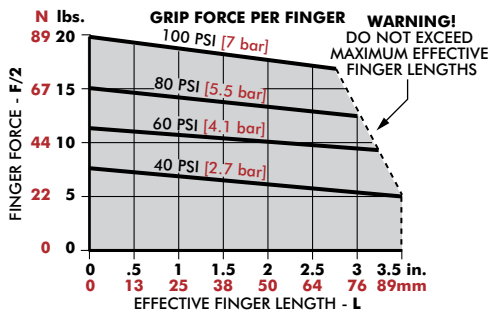

RP-12	Static	Dynamic
Maximum Tensile <b>T</b>	890 N [200 lbs]	111 N [25 lbs]
Maximum Compressive <b>C</b>	1779 N [400 lbs]	111 N [25 lbs]
Maximum Moment <b>M<sub>x</sub></b>	17 Nm [150 in-lbs]	3 Nm [25 in-lbs]
Maximum Moment <b>M<sub>y</sub></b>	17 Nm [150 in-lbs]	3 Nm [25 in-lbs]
Maximum Moment <b>M<sub>z</sub></b>	17 Nm [150 in-lbs]	3 Nm [25 in-lbs]

Capacities are per set of jaws and are not simultaneous

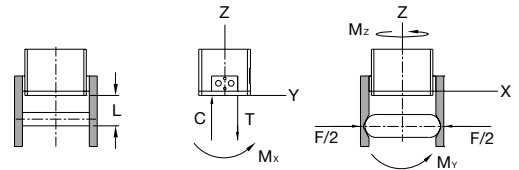
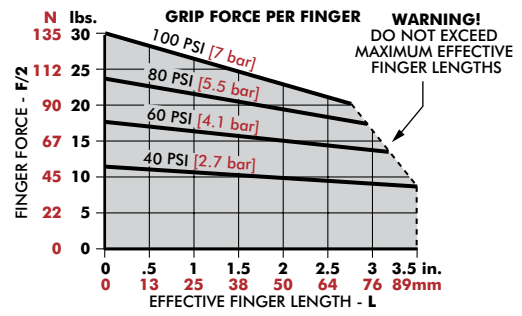

RP-12-D	Static	Dynamic
Maximum Tensile <b>T</b>	890 N [200 lbs]	111 N [25 lbs]
Maximum Compressive <b>C</b>	1779 N [400 lbs]	111 N [25 lbs]
Maximum Moment <b>M<sub>x</sub></b>	17 Nm [150 in-lbs]	3 Nm [25 in-lbs]
Maximum Moment <b>M<sub>y</sub></b>	17 Nm [150 in-lbs]	3 Nm [25 in-lbs]
Maximum Moment <b>M<sub>z</sub></b>	17 Nm [150 in-lbs]	3 Nm [25 in-lbs]

Capacities are per set of jaws and are not simultaneous

# RP-15

## 2-Jaw General Industrial Parallel Grippers | Dimensions and Technical Specifications

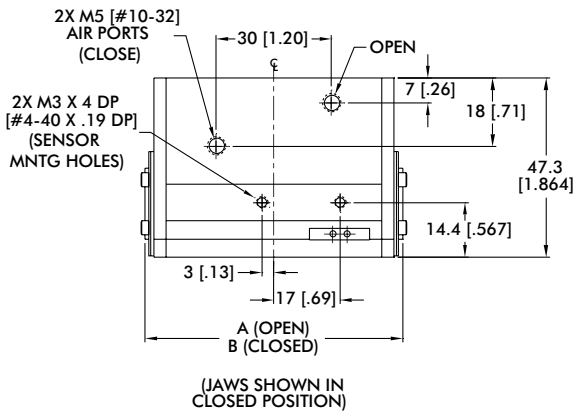
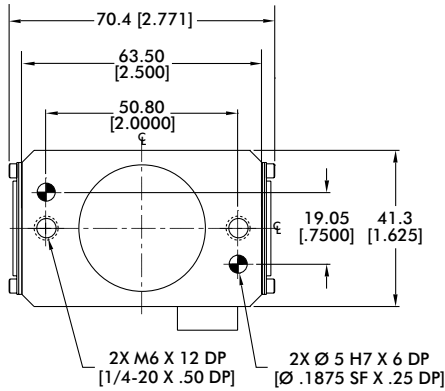

Model	A	B
RP-15	81 [3.19]	68 [2.69]
RP-15-D	76 [3.00]	68 [2.69]

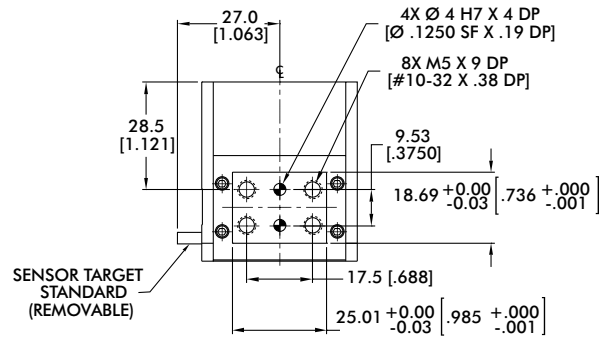
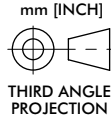

## Loading Information

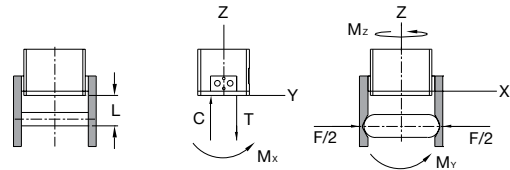
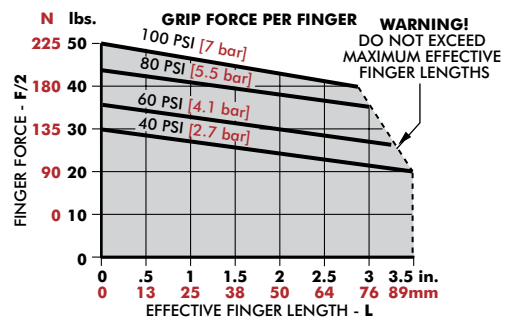
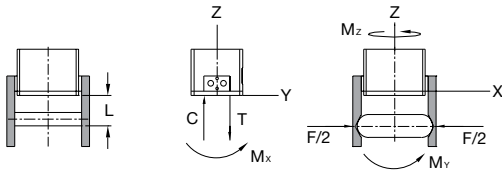
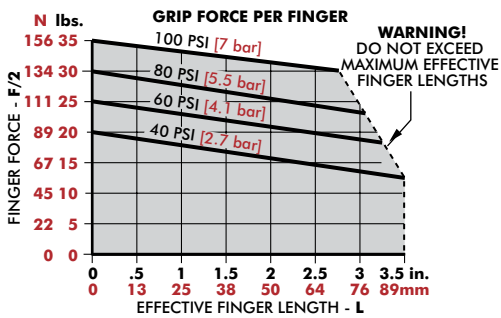

RP-15	Static	Dynamic
Maximum Tensile <b>T</b>	1779 N [400 lbs]	222 N [50 lbs]
Maximum Compressive <b>C</b>	3336 N [750 lbs]	222 N [50 lbs]
Maximum Moment <b>M<sub>x</sub></b>	34 Nm [300 in-lbs]	6 Nm [50 in-lbs]
Maximum Moment <b>M<sub>y</sub></b>	34 Nm [300 in-lbs]	6 Nm [50 in-lbs]
Maximum Moment <b>M<sub>z</sub></b>	34 Nm [300 in-lbs]	6 Nm [50 in-lbs]

\*Capacities are per set of jaws and are not simultaneous

RP-15-D	Static	Dynamic
Maximum Tensile <b>T</b>	1779 N [400 lbs]	222 N [50 lbs]
Maximum Compressive <b>C</b>	3336 N [750 lbs]	222 N [50 lbs]
Maximum Moment <b>M<sub>x</sub></b>	34 Nm [300 in-lbs]	6 Nm [50 in-lbs]
Maximum Moment <b>M<sub>y</sub></b>	34 Nm [300 in-lbs]	6 Nm [50 in-lbs]
Maximum Moment <b>M<sub>z</sub></b>	34 Nm [300 in-lbs]	6 Nm [50 in-lbs]

\*Capacities are per set of jaws and are not simultaneous

## 2-Jaw General Industrial Parallel Grippers | Dimensions and Technical Specifications

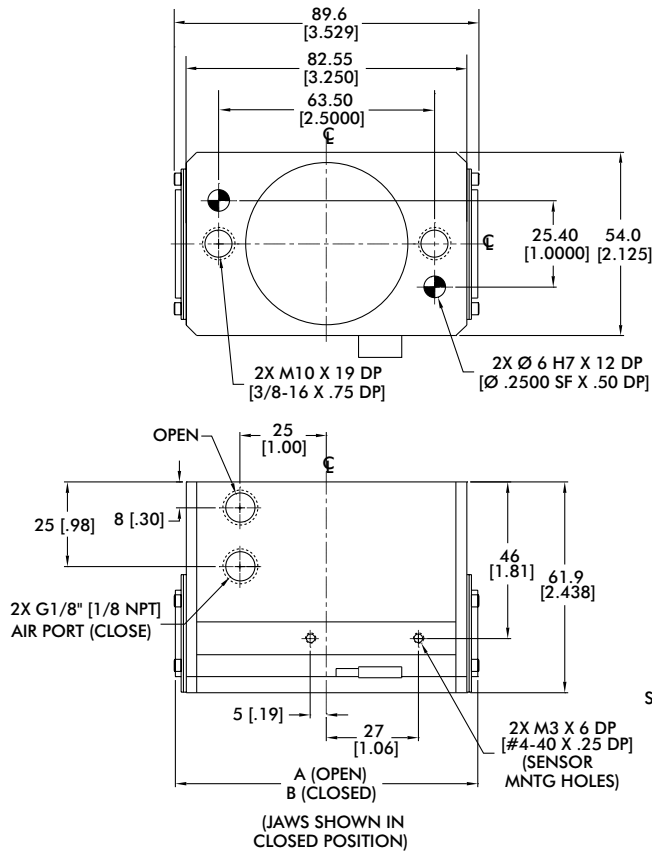

Model	A	B
RP-17	107 [4.25]	89 [3.50]
RP-17-D	117 [4.60]	

Sensor Accessories		RP-17
Inductive Sensor Mounting Kit (mounts 2 sensors)		OSMK-072
Seal Repair Kits		RP-17
Buna-N Seal Repair Kit		SLKT-042
Viton® Seal Repair Kit		SLKT-042V
Pneumatic Accessories		RP-17
Fail Safe Valve (Imperial)		OFSV-002
Fail Safe Valve (Metric)		OFSV-005

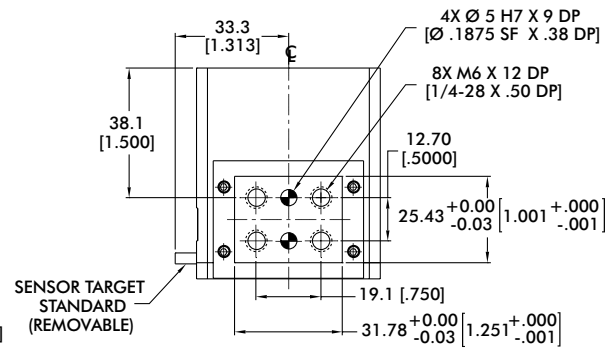

## Loading Information

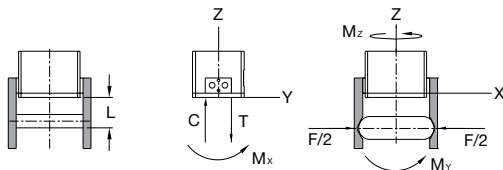
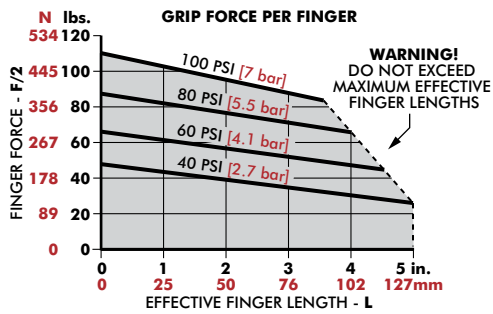

RP-17	Static	Dynamic
Maximum Tensile <b>T</b>	3336 N [750 lbs]	445 N [100 lbs]
Maximum Compressive <b>C</b>	6672 N [1500 lbs]	445 N [100 lbs]
Maximum Moment <b>M<sub>x</sub></b>	85 Nm [750 in-lbs]	14 Nm [125 in-lbs]
Maximum Moment <b>M<sub>y</sub></b>	85 Nm [750 in-lbs]	14 Nm [125 in-lbs]
Maximum Moment <b>M<sub>z</sub></b>	85 Nm [750 in-lbs]	14 Nm [125 in-lbs]

<sup>1</sup>Capacities are per set of jaws and are not simultaneous

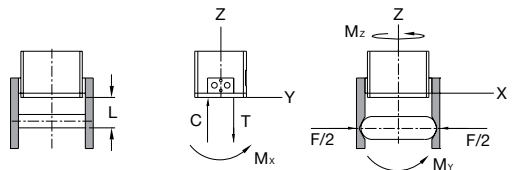
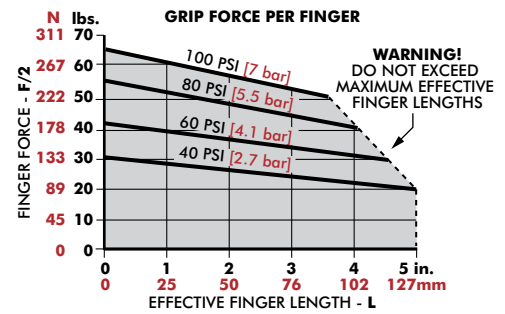

RP-17-D	Static	Dynamic
Maximum Tensile <b>T</b>	3336 N [750 lbs]	445 N [100 lbs]
Maximum Compressive <b>C</b>	6672 N [1500 lbs]	445 N [100 lbs]
Maximum Moment <b>M<sub>x</sub></b>	85 Nm [750 in-lbs]	14 Nm [125 in-lbs]
Maximum Moment <b>M<sub>y</sub></b>	85 Nm [750 in-lbs]	14 Nm [125 in-lbs]
Maximum Moment <b>M<sub>z</sub></b>	85 Nm [750 in-lbs]	14 Nm [125 in-lbs]

<sup>1</sup>Capacities are per set of jaws and are not simultaneous

# RP-18

## 2-Jaw General Industrial Parallel Grippers | Dimensions and Technical Specifications

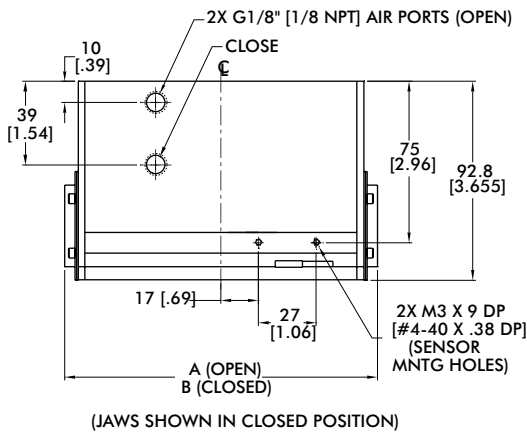
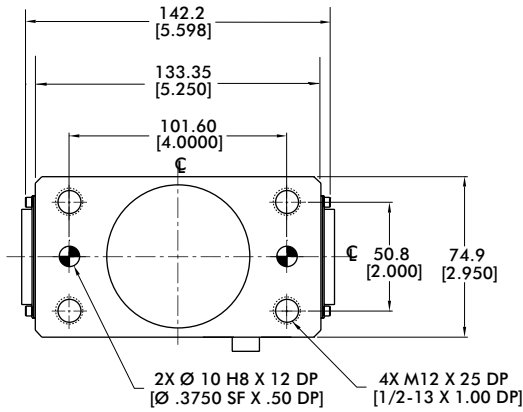

Model	A	B
RP-18	177 [7.00]	146 [5.75]
RP-18-D	190 [7.45]	

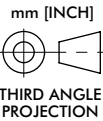
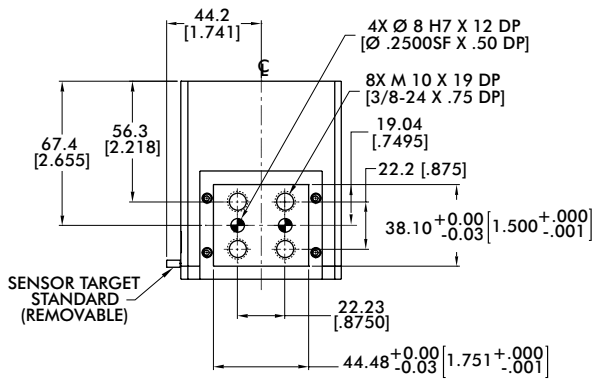

Sensor Accessories	RP-18
Inductive Sensor Mounting Kit (mounts 2 sensors)	OSMK-072

Seal Repair Kits	RP-18
Buna-N Seal Repair Kit	SLKT-043
Viton® Seal Repair Kit	SLKT-043V

Pneumatic Accessories	RP-18
Fail Safe Valve (Imperial)	OFSV-002
Fail Safe Valve (Metric)	OFSV-005

### Loading Information

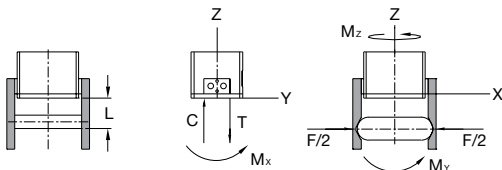
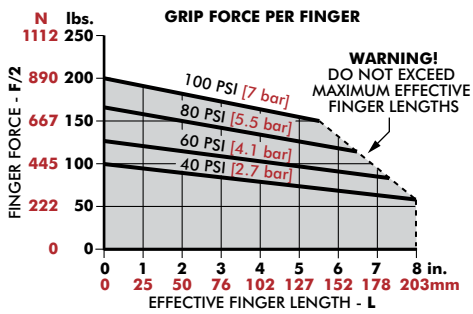

RP-18	Static	Dynamic
Maximum Tensile <b>T</b>	6672 N [1500 lbs]	1112 N [250 lbs]
Maximum Compressive <b>C</b>	13345 N [3000 lbs]	1112 N [250 lbs]
Maximum Moment <b>M<sub>x</sub></b>	170 Nm [1500 in-lbs]	28 Nm [250 in-lbs]
Maximum Moment <b>M<sub>y</sub></b>	170 Nm [1500 in-lbs]	28 Nm [250 in-lbs]
Maximum Moment <b>M<sub>z</sub></b>	170 Nm [1500 in-lbs]	28 Nm [250 in-lbs]

\*Capacities are per set of jaws and are not simultaneous

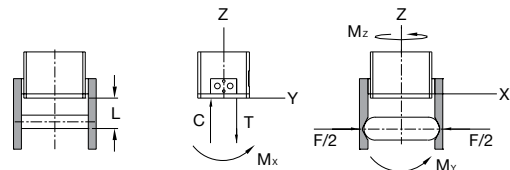
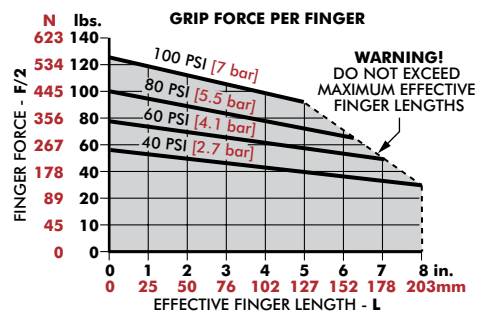

RP-18-D	Static	Dynamic
Maximum Tensile <b>T</b>	6672 N [1500 lbs]	1112 N [250 lbs]
Maximum Compressive <b>C</b>	13345 N [3000 lbs]	1112 N [250 lbs]
Maximum Moment <b>M<sub>x</sub></b>	170 Nm [1500 in-lbs]	28 Nm [250 in-lbs]
Maximum Moment <b>M<sub>y</sub></b>	170 Nm [1500 in-lbs]	28 Nm [250 in-lbs]
Maximum Moment <b>M<sub>z</sub></b>	170 Nm [1500 in-lbs]	28 Nm [250 in-lbs]

\*Capacities are per set of jaws and are not simultaneous

## 2-Jaw General Industrial Parallel Grippers | Dimensions and Technical Specifications

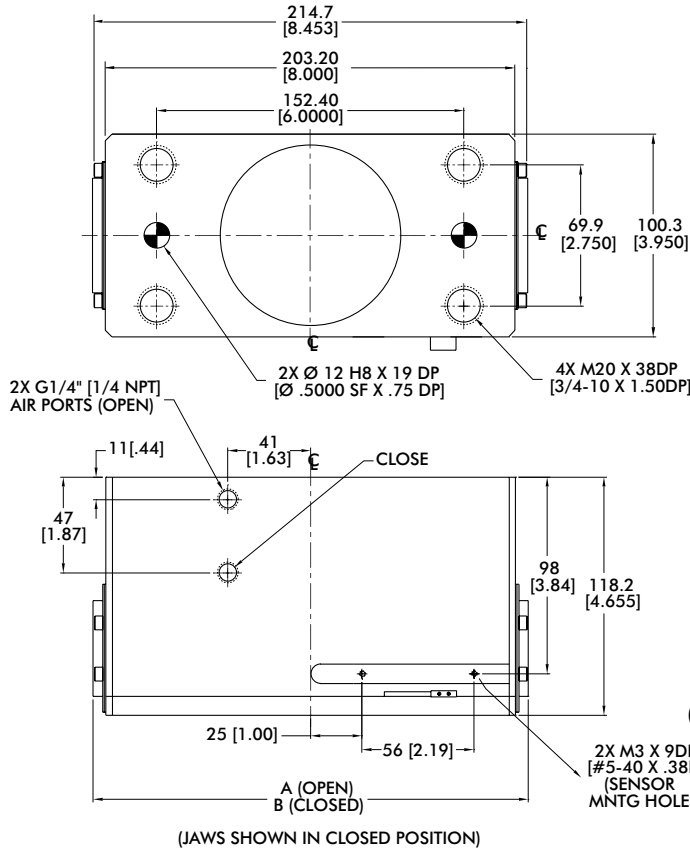

Model	A	B
RP-19	266 [10.50]	216 [8.50]
RP-19-D	254 [10.00]	

Sensor Accessories	RP-19
Inductive Sensor Mounting Kit (mounts 2 sensors)	OSMK-073

Seal Repair Kits	RP-19
Buna-N Seal Repair Kit	SLKT-044
Viton® Seal Repair Kit	SLKT-044V

Pneumatic Accessories	RP-19
Fail Safe Valve (Imperial)	OFSV-003
Fail Safe Valve (Metric)	OFSV-006

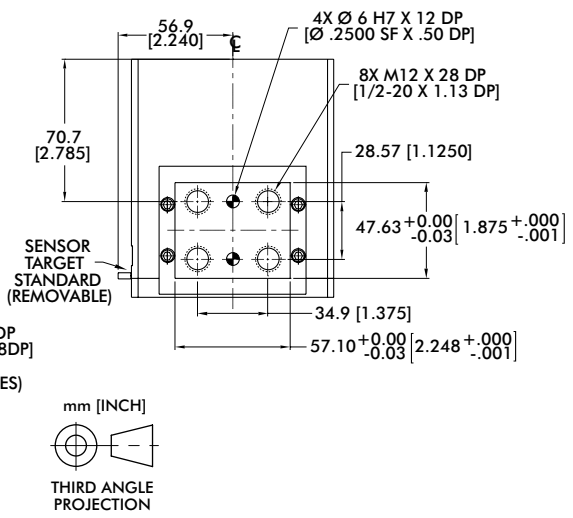

### Loading Information

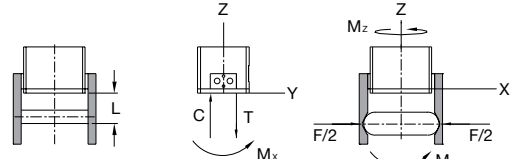
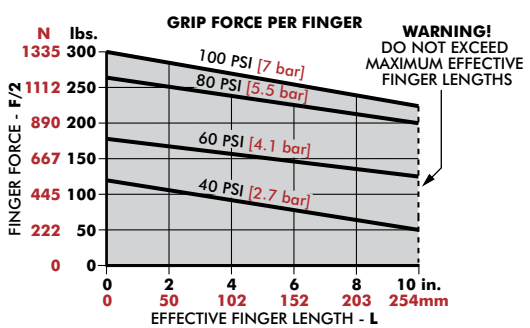

RP-19	Static	Dynamic
Maximum Tensile <b>T</b>	13345 N [3000 lbs]	1334 N [300 lbs]
Maximum Compressive <b>C</b>	26689 N [6000 lbs]	1334 N [300 lbs]
Maximum Moment <b>M<sub>x</sub></b>	565 Nm [5000 in-lbs]	56 Nm [500 in-lbs]
Maximum Moment <b>M<sub>y</sub></b>	565 Nm [5000 in-lbs]	56 Nm [500 in-lbs]
Maximum Moment <b>M<sub>z</sub></b>	565 Nm [5000 in-lbs]	56 Nm [500 in-lbs]

<sup>†</sup>Capacities are per set of jaws and are not simultaneous

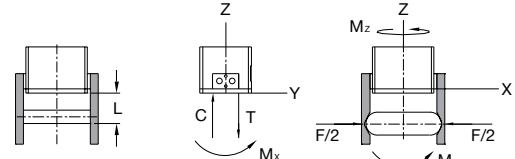
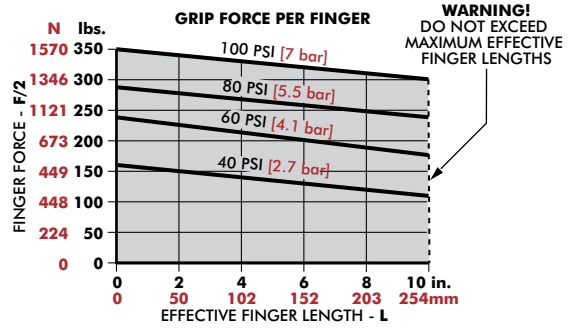

RP-19-D	Static	Dynamic
Maximum Tensile <b>T</b>	13345 N [3000 lbs]	1334 N [300 lbs]
Maximum Compressive <b>C</b>	26689 N [6000 lbs]	1334 N [300 lbs]
Maximum Moment <b>M<sub>x</sub></b>	565 Nm [5000 in-lbs]	56 Nm [500 in-lbs]
Maximum Moment <b>M<sub>y</sub></b>	565 Nm [5000 in-lbs]	56 Nm [500 in-lbs]
Maximum Moment <b>M<sub>z</sub></b>	565 Nm [5000 in-lbs]	56 Nm [500 in-lbs]

<sup>†</sup>Capacities are per set of jaws and are not simultaneous