

RDH SERIES

2-Jaw General Industrial Grippers | Features and Benefits | How To Order

Features:

- Rugged multi-purpose powerful gripper
- 8 sizes for small lightweight to very large and heavy part gripping
- High impact resistant with double wedge design
- Shielded gripper to repel metal chips and particulates
- Spring assist option maintains grip in case of air pressure loss
- Purge and scavenge ports for harsh & clean environments
- Multi-position sensing up to 4 locations

Applications:

- High particulate application environments
- Automotive engine block and gantry systems
- Ideal for very heavy part gripping

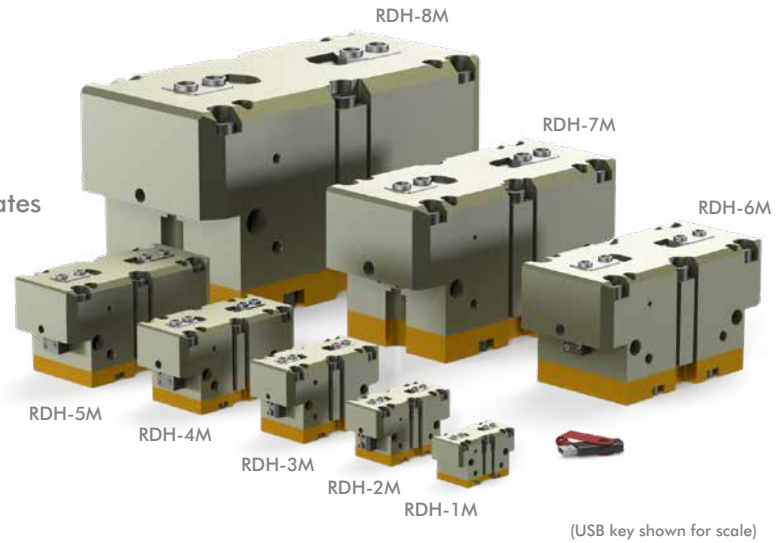

How To Order

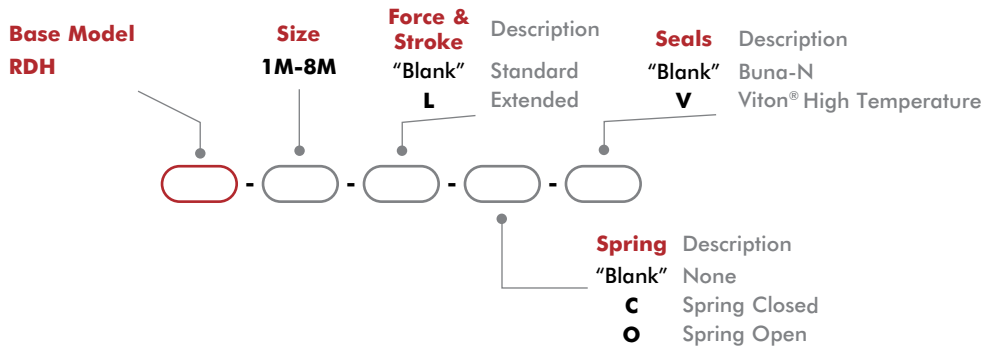

Accessories

Sensor Accessories	Model Numbers	Part Number	Qty/Unit
8mm PNP Magneto Resistive Sensor (90° barrel) w/ M8 Qk. Disc*	All Models	OHSP-011	1-4
8mm NPN Magneto Resistive Sensor (90° barrel) w/ M8 Qk. Disc*	All Models	OHSN-011	1-4
8mm PNP Magneto Resistive Sensor Short Barrel w/ M8 Qk Disc*	All Models	OHSP-017	1-4
8mm NPN Magneto Resistive Sensor Short Barrel w/ M8 Qk Disc*	All Models	OHSN-017	1-4
8mm PNP Inductive Sensor w/ M12 Quick Disconnect*	RDH-4M, -5M, -6M	OISP-011	1-2
8mm NPN Inductive Sensor w/ M12 Quick Disconnect*	RDH-4M, -5M, -6M	OISN-011	1-2
12mm PNP Inductive Sensor w/ M12 Quick Disconnect*	RDH-7M, -8M	OISP-017	1-2
12mm NPN Inductive Sensor w/ M12 Quick Disconnect*	RDH-7M, -8M	OISN-017	1-2
M8 Quick Disconnect 2 Meter Cable Length*	All Models	CABL-010	1-4
M8 Quick Disconnect 5 Meter Cable Length*	All Models	CABL-013	1-4
M12 Quick Disconnect 2 Meter Cable Length*	RDH-7M, -8M	CABL-014	1-2
M12 Quick Disconnect 5 Meter Cable Length*	RDH-7M, -8M	CABL-018	1-2

Pneumatic Accessories	Model Numbers	Part Number	Qty/Unit
M5 Adjustable Flow Control	RDH-1M, -2M, -3M	VLVF-008	1-2
G 1/4" Adjustable Flow Control	RDH-4M, -5M, -6M, -7M	VLVF-005	1-2
G 1/8" Adjustable Flow Control	RDH-8M	VLVF-010	1-2

* Sensor and cable sold separately.

2-Jaw General Industrial Grippers | Technical Specifications

Specifications	Units	1M	1M-L	2M	2M-L	3M	3M-L	4M	4M-L	
Total Rated Grip Force F @ 100 psi [7 bar] w/o Spring Assist	N [lbs]	555 [125]	361 [81]	754 [170]	494 [111]	1317 [296]	854 [192]	2177 [490]	1414 [318]	
Total Rated Grip Force F @ 100 psi [7 bar] with Spring Assist	N [lbs]	693 [156]	452 [102]	1006 [226]	661 [149]	1683 [379]	1094 [246]	2789 [628]	1814 [408]	
Total Stroke	mm [in]	4 [0.16]	8 [0.32]	6 [0.24]	12 [0.47]	8 [0.31]	16 [0.63]	10 [0.39]	20 [0.79]	
Weight	kg [lbs]	0.19 [0.4]	0.21 [0.5]	0.39 [0.86]	0.42 [0.93]	0.82 [1.81]	0.88 [1.94]	1.43 [3.15]	1.51 [3.33]	
Pressure Range w/o Spring	bar [psi]	2-7 [30-100]								
Pressure Range with Spring	bar [psi]	3.5-7 [50-100]								
Max. Vacuum for Scavenge Port	mm Hg [in Hg]	200 [8]								
Max. Pressure for Purge Port	bar [psi]	2.1 [30]								
Ingress Protection Class (IP)		IP55								
Displacement	cm ³ [in ³]	5 [0.31]	10.3 [0.63]		23.4 [1.43]		47.5 [2.90]			
Temperature Range (Buna-N seals)	°C [°F]	-35°~80° [-30°~180°]								
Temperature Range (Viton® seals)	°C [°F]	-30°~150° [-20°~300°]								
Actuation (open/close)	sec.	0.06		0.07		0.08				
Accuracy	mm [in]	±0.04 [±0.002]						±0.06 [±0.0024]		
Repeatability	mm [in]	±0.02 [±0.001]						±0.03 [±0.0012]		
Valve to Actuate Single Acting		3-way, 2-position								
Valve to Actuate Double Acting		4-way, 2-position								

Specifications (cont.)	Units	5M	5M-L	6M	6M-L	7M	7M-L	8M	8M-L
Total Rated Grip Force F @ 100 psi [7 bar] w/o Spring Assist	N [lbs]	3593 [808]	2333 [525]	6250 [1406]	4062 [914]	9901 [2228]	6404 [1441]	21958 [4941]	14178 [3190]
Total Rated Grip Force F @ 100 psi [7 bar] with Spring Assist	N [lbs]	4609 [1037]	2999 [675]	8640 [1944]	5623 [1265]	12542 [2822]	8135 [1830]	28002 [6300]	18115 [4076]
Total Stroke	mm [in]	13 [0.51]	26 [1.02]	16 [0.63]	32 [1.26]	25 [0.98]	50 [1.97]	35 [1.38]	70 [2.76]
Weight	kg [lbs]	2.75 [6.06]	2.98 [6.57]	5.77 [12.72]		11.25 [24.8]		32.3 [71.1]	
Pressure Range w/o Spring	bar [psi]	2-7 [30-100]							
Pressure Range with Spring	bar [psi]	4-7 [60-100]	4.5-7 [65-100]		4-7 [60-100]		3.5-7 [50-100]		
Max. Vacuum for Scavenge Port	mm Hg [in Hg]	20 [8]							
Max. Pressure for Purge Port	bar [psi]	2.1 [30]							
Ingress Protection Class (IP)		IP55							
Displacement	cm ³ [in ³]	102 [6.22]	216 [13.18]		540 [32.95]		1689 [103.1]		
Temperature Range (Buna-N seals)	°C [°F]	-35°~80° [-30°~180°]							
Temperature Range (Viton® seals)	°C [°F]	-30°~150° [-20°~300°]							
Actuation (open/close)	sec.	0.14		0.20		0.55		1.3	
Accuracy	mm [in]	±0.06 [±0.0024]		±0.08 [±0.0031]		±0.1 [±0.0039]			
Repeatability	mm [in]	±0.03 [±0.0012]		±0.04 [±0.0016]		±0.05 [±0.002]			
Valve to Actuate Single Acting		3-way, 2-position							
Valve to Actuate Double Acting		4-way, 2-position							

RDH-1M, -1M-L

2-Jaw General Industrial Grippers | Dimensions and Technical Specifications

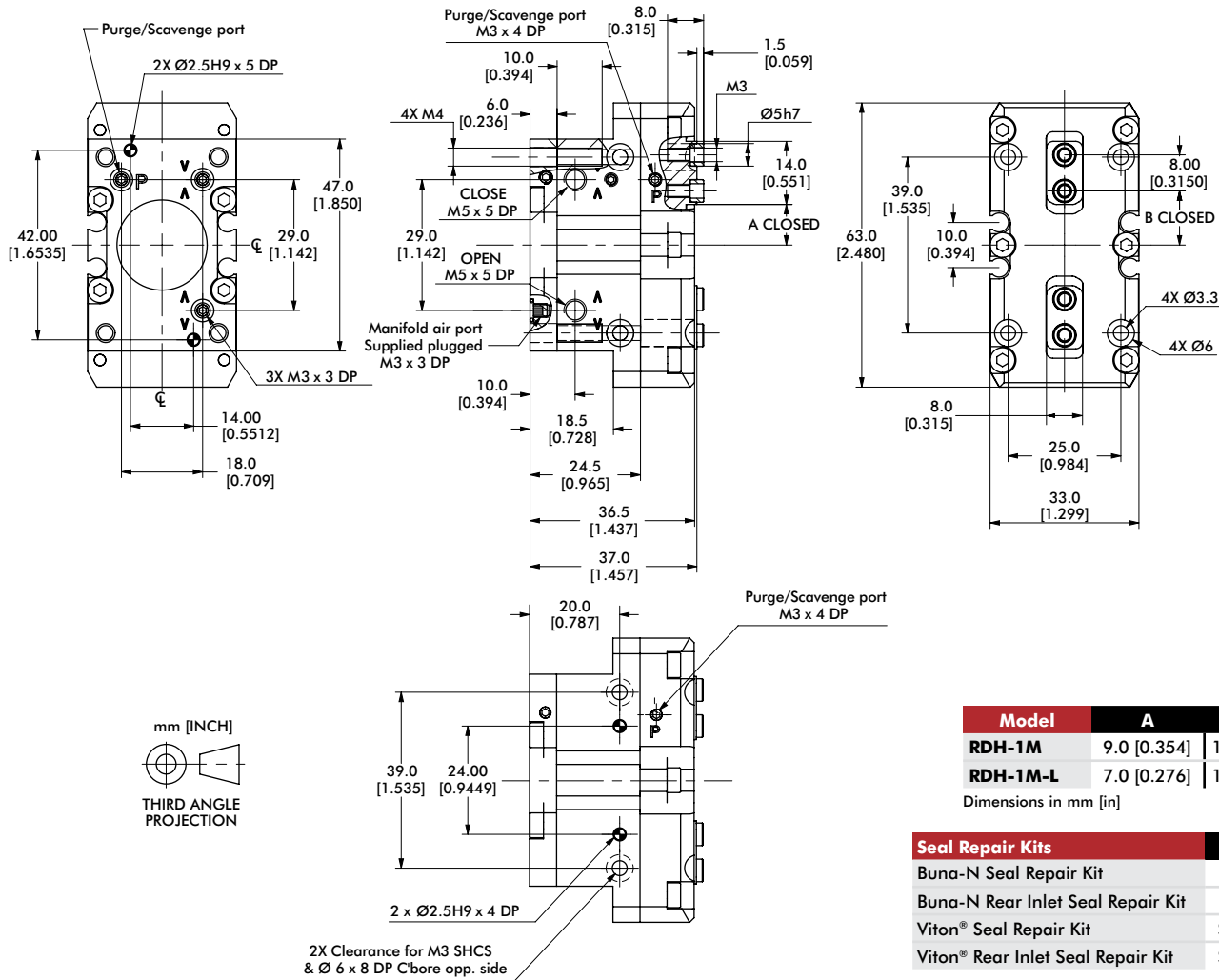

Loading Information

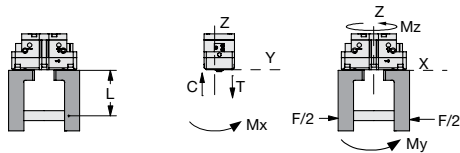
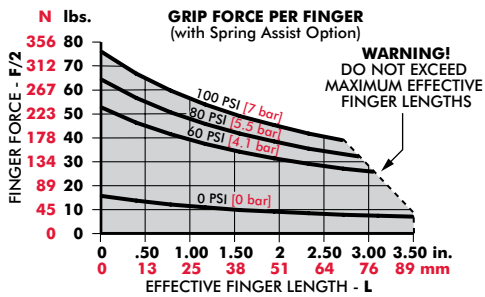

RDH-1M	Static	Dynamic
Maximum Tensile T	594 N [134 lbs]	74 N [17 lbs]
Maximum Compressive C	779 N [175 lbs]	74 N [17 lbs]
Maximum Moment M_x	18 Nm [159 in-lbs]	2 Nm [18 in-lbs]
Maximum Moment M_y	23 Nm [204 in-lbs]	2 Nm [18 in-lbs]
Maximum Moment M_z	14 Nm [124 in-lbs]	2 Nm [18 in-lbs]

*Capacities are per set of jaws and are not simultaneous

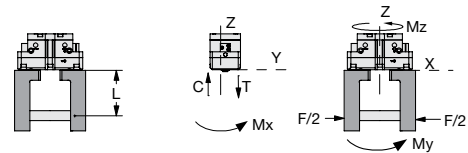
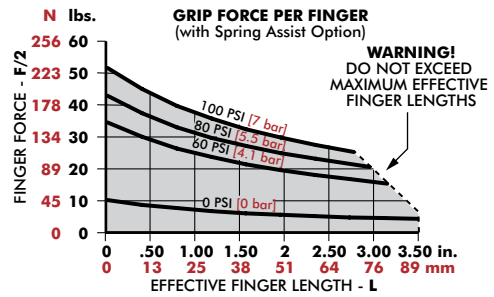

RDH-1M-L	Static	Dynamic
Maximum Tensile T	540 N [121 lbs]	48 N [11 lbs]
Maximum Compressive C	708 N [159 lbs]	48 N [11 lbs]
Maximum Moment M_x	16 Nm [142 in-lbs]	1 Nm [9 in-lbs]
Maximum Moment M_y	19 Nm [168 in-lbs]	1 Nm [9 in-lbs]
Maximum Moment M_z	12 Nm [106 in-lbs]	1 Nm [9 in-lbs]

*Capacities are per set of jaws and are not simultaneous

RDH-2M, -2M-L

2-Jaw General Industrial Grippers | Dimensions and Technical Specifications

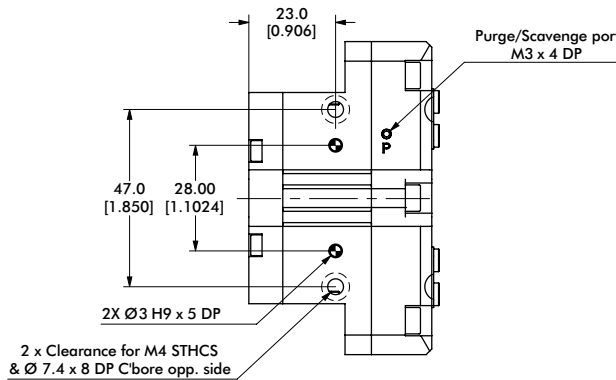
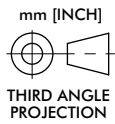
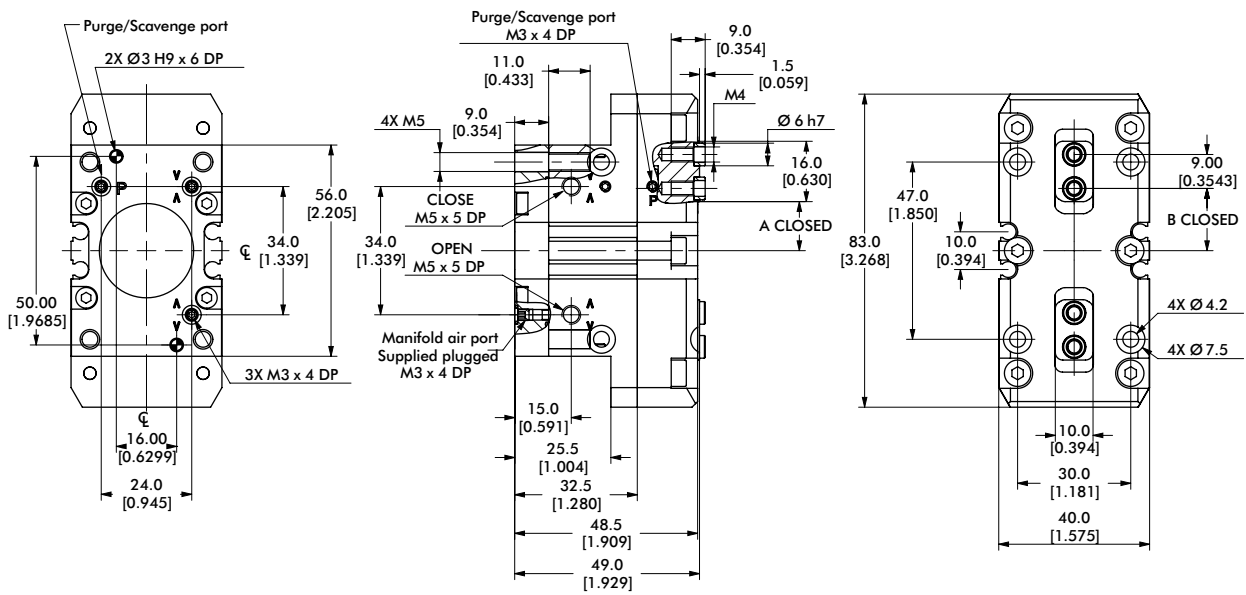

Model	A	B
RDH-2M	13.0 [0.512]	16.5 [0.650]
RDH-2M-L	10.0 [0.394]	13.5 [0.531]

Dimensions in mm [in]

Seal Repair Kits	RDH-2M
Buna-N Seal Repair Kit	SLKT-417
Buna-N Rear Inlet Seal Repair Kit	SLKT-363
Viton® Seal Repair Kit	SLKT-417V
Viton® Rear Inlet Seal Repair Kit	SLKT-363V

Loading Information

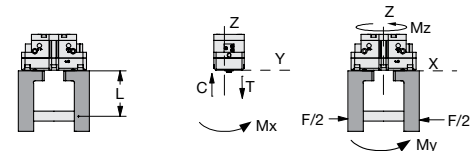
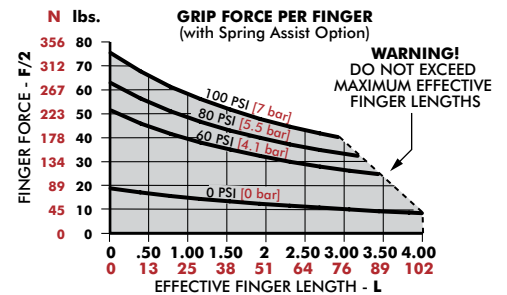
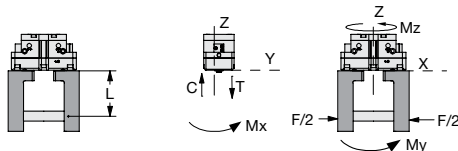
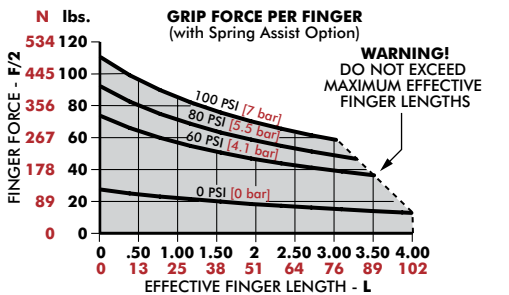

RDH-2M	Static	Dynamic
Maximum Tensile T	849 N [191 lbs]	81 N [18 lbs]
Maximum Compressive C	1103 N [248 lbs]	81 N [18 lbs]
Maximum Moment M_x	36 Nm [319 in-lbs]	3 Nm [27 in-lbs]
Maximum Moment M_y	51 Nm [451 in-lbs]	4 Nm [35 in-lbs]
Maximum Moment M_z	32 Nm [283 in-lbs]	4 Nm [35 in-lbs]

†Capacities are per set of jaws and are not simultaneous

RDH-2M-L	Static	Dynamic
Maximum Tensile T	764 N [172 lbs]	53 N [12 lbs]
Maximum Compressive C	993 N [223 lbs]	53 N [12 lbs]
Maximum Moment M_x	32 Nm [283 in-lbs]	2 Nm [18 in-lbs]
Maximum Moment M_y	41 Nm [363 in-lbs]	2 Nm [18 in-lbs]
Maximum Moment M_z	26 Nm [230 in-lbs]	2 Nm [18 in-lbs]

†Capacities are per set of jaws and are not simultaneous

RDH-3M, -3M-L

2-Jaw General Industrial Grippers | Dimensions and Technical Specifications

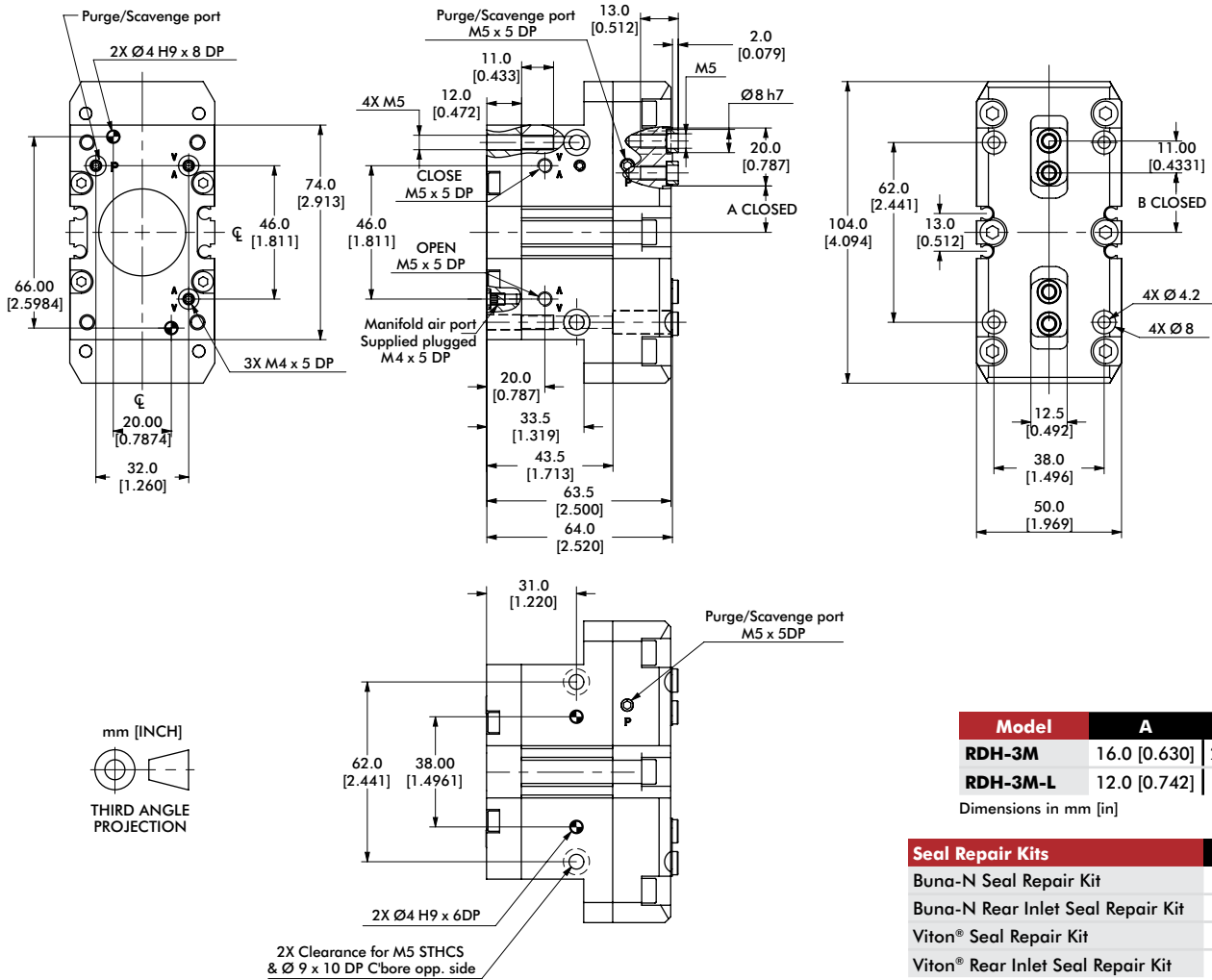

Loading Information

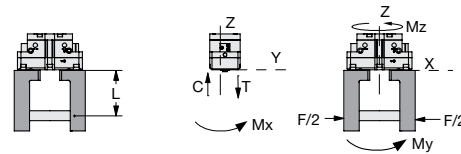
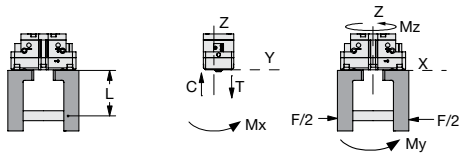
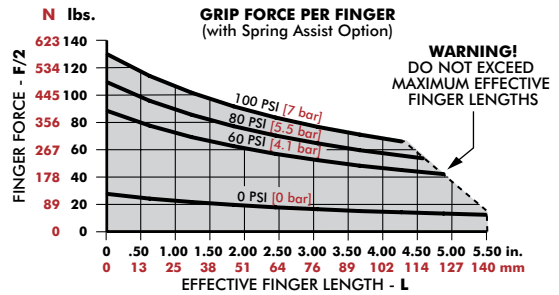
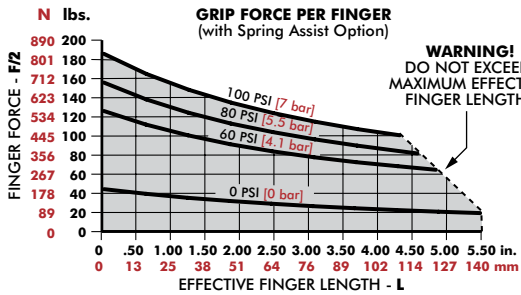

RDH-3M	Static	Dynamic
Maximum Tensile T	1284 N [289 lbs]	196 N [44 lbs]
Maximum Compressive C	1665 N [374 lbs]	196 N [44 lbs]
Maximum Moment M_x	58 Nm [513 in-lbs]	7 Nm [62 in-lbs]
Maximum Moment M_y	83 Nm [735 in-lbs]	11 Nm [97 in-lbs]
Maximum Moment M_z	54 Nm [478 in-lbs]	11 Nm [97 in-lbs]

[†]Capacities are per set of jaws and are not simultaneous

RDH-3M-L	Static	Dynamic
Maximum Tensile T	1146 N [258 lbs]	127 N [29 lbs]
Maximum Compressive C	1485 N [334 lbs]	127 N [29 lbs]
Maximum Moment M_x	52 Nm [460 in-lbs]	5 Nm [44 in-lbs]
Maximum Moment M_y	66 Nm [584 in-lbs]	6 Nm [53 in-lbs]
Maximum Moment M_z	43 Nm [381 in-lbs]	[53 in-lbs] 6 Nm

[†]Capacities are per set of jaws and are not simultaneous

RDH-4M, -4M-L

2-Jaw General Industrial Grippers | Dimensions and Technical Specifications

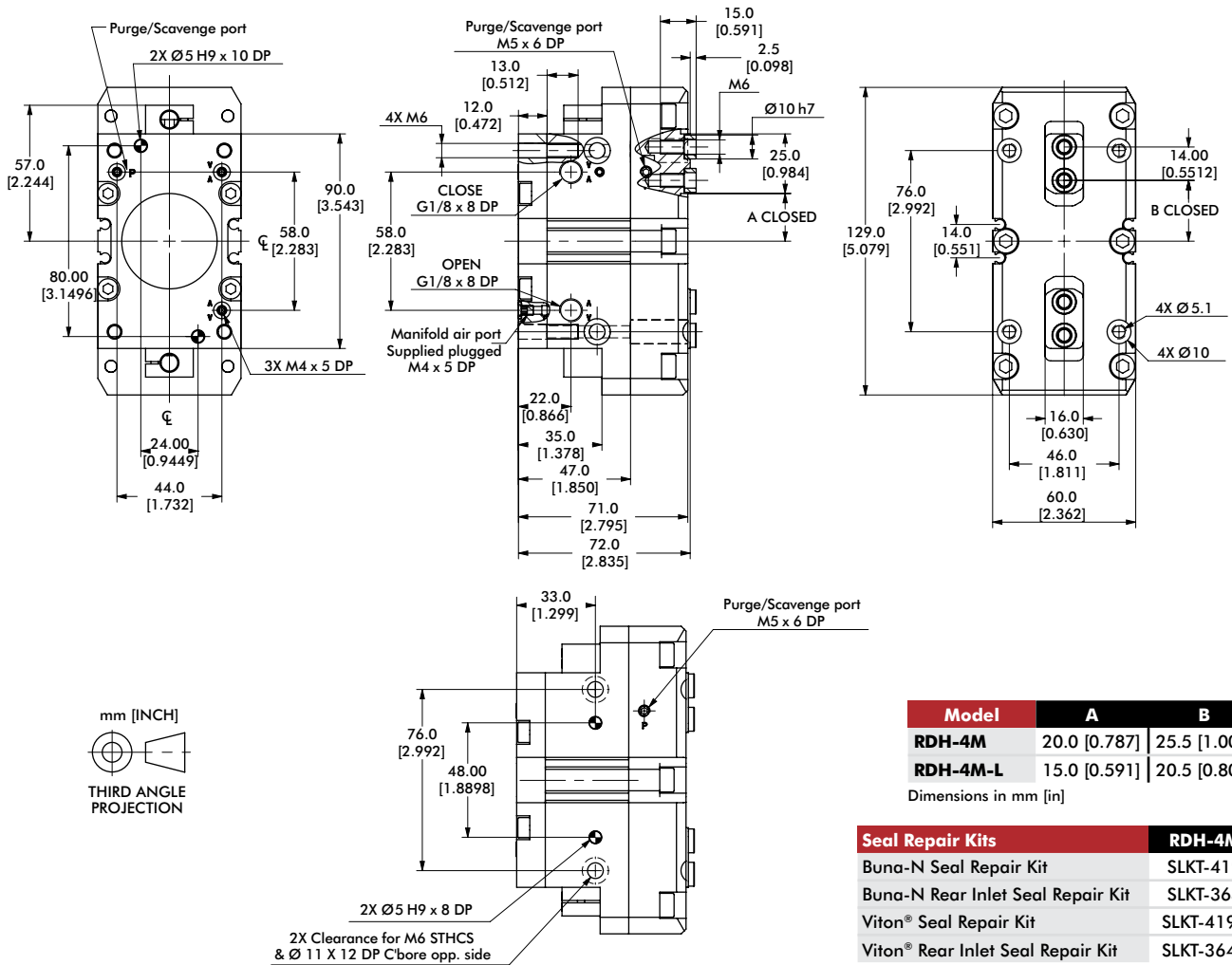

Loading Information

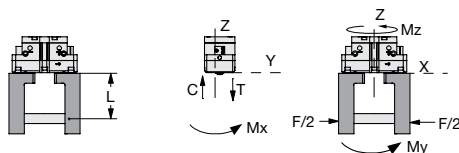
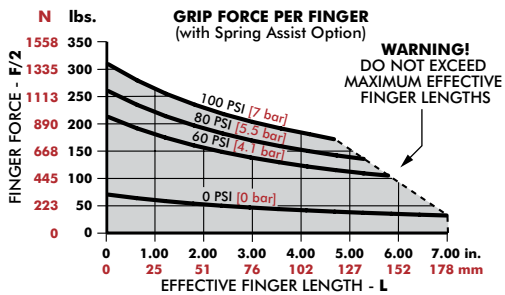

RDH-4M	Static	Dynamic
Maximum Tensile T	1564 N [352 lbs]	259 N [58 lbs]
Maximum Compressive C	2070 N [465 lbs]	259 N [58 lbs]
Maximum Moment M_x	76 Nm [673 in-lbs]	10 Nm [89 in-lbs]
Maximum Moment M_y	106 Nm [938 in-lbs]	14 Nm [124 in-lbs]
Maximum Moment M_x	70 Nm [620 in-lbs]	14 Nm [124 in-lbs]

¹Capacities are per set of jaws and are not simultaneous

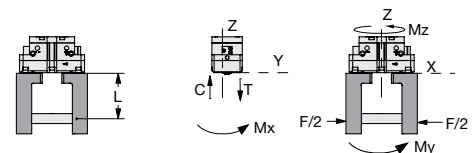
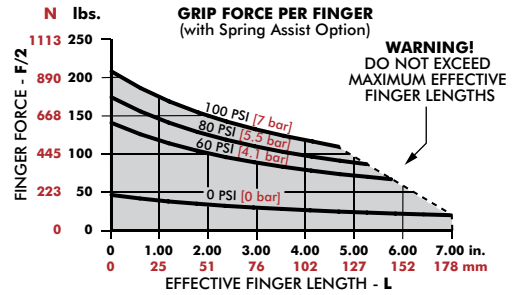

RDH-4M-L	Static	Dynamic
Maximum Tensile T	1394 N [313 lbs]	168 N [38 lbs]
Maximum Compressive C	1845 N [415 lbs]	168 N [38 lbs]
Maximum Moment M_x	68 Nm [602 in-lbs]	6 Nm [53 in-lbs]
Maximum Moment M_y	84 Nm [743 in-lbs]	8 Nm [71 in-lbs]
Maximum Moment M_x	56 Nm [496 in-lbs]	8 Nm [71 in-lbs]

¹Capacities are per set of jaws and are not simultaneous

RDH-5M, -5M-L

2-Jaw General Industrial Grippers | Dimensions and Technical Specifications

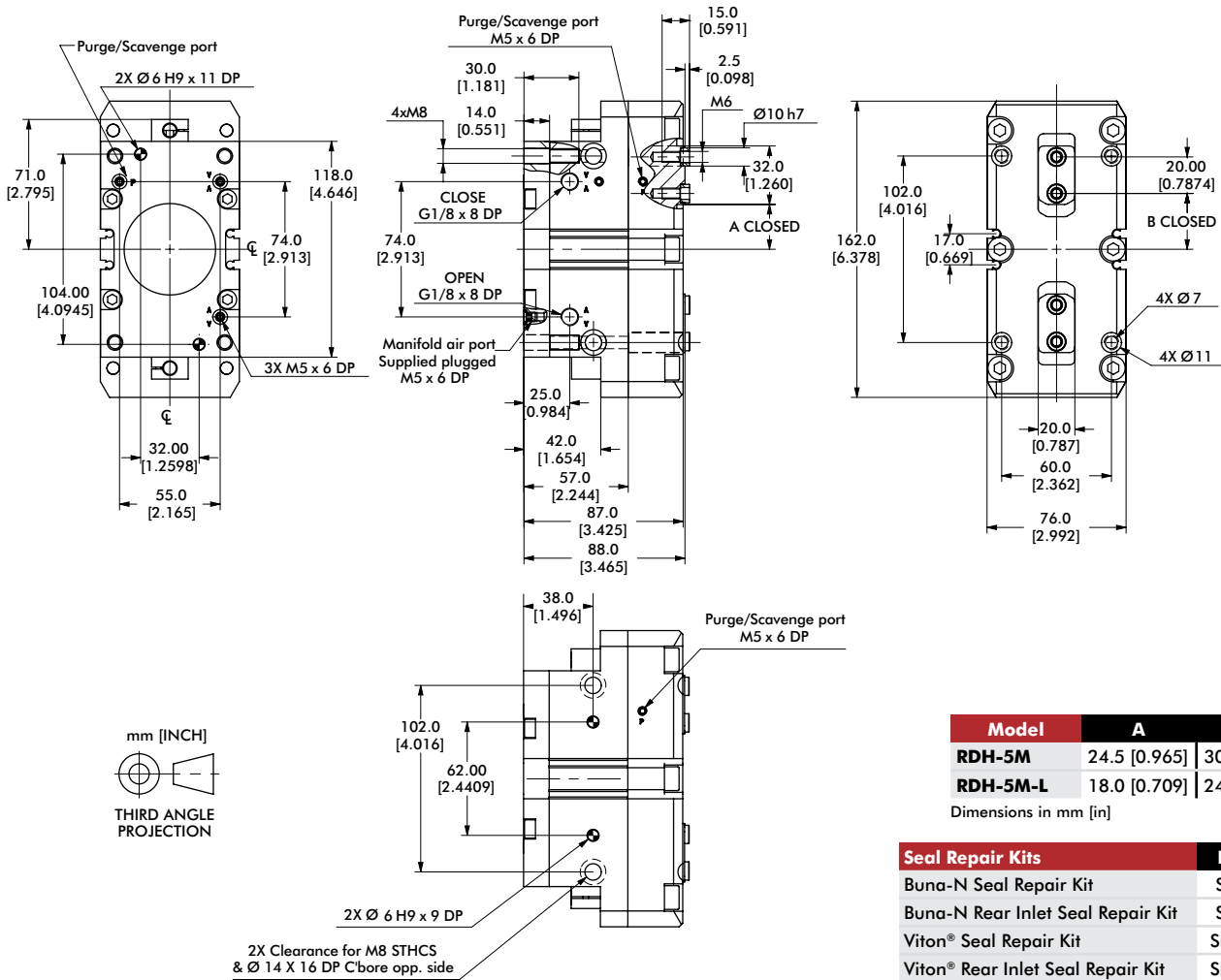

Loading Information

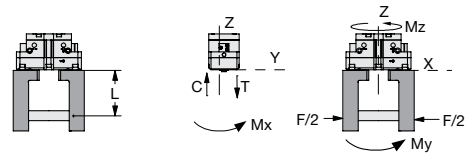
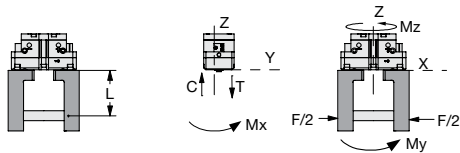
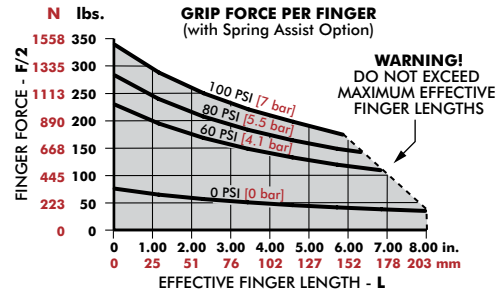
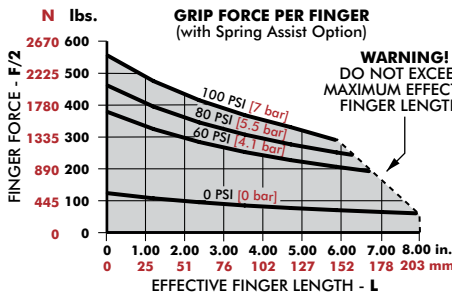

	Static	Dynamic
Maximum Tensile T	2192 N [493 lbs]	428 N [96 lbs]
Maximum Compressive C	2923 N [657 lbs]	428 N [96 lbs]
Maximum Moment M_x	105 Nm [929 in-lbs]	16 Nm [142 in-lbs]
Maximum Moment M_y	148 Nm [1310 in-lbs]	22 Nm [195 in-lbs]
Maximum Moment M_z	97 Nm [859 in-lbs]	22 Nm [195 in-lbs]

	Static	Dynamic
Maximum Tensile T	1966 N [442 lbs]	278 N [62 lbs]
Maximum Compressive C	2621 N [589 lbs]	278 N [62 lbs]
Maximum Moment M_x	94 Nm [832 in-lbs]	10 Nm [89 in-lbs]
Maximum Moment M_y	119 Nm [1053 in-lbs]	13 Nm [115 in-lbs]
Maximum Moment M_z	78 Nm [690 in-lbs]	13 Nm [115 in-lbs]

*Capacities are per set of jaws and are not simultaneous

*Capacities are per set of jaws and are not simultaneous

RDH-6M, -6M-L

2-Jaw General Industrial Grippers | Dimensions and Technical Specifications

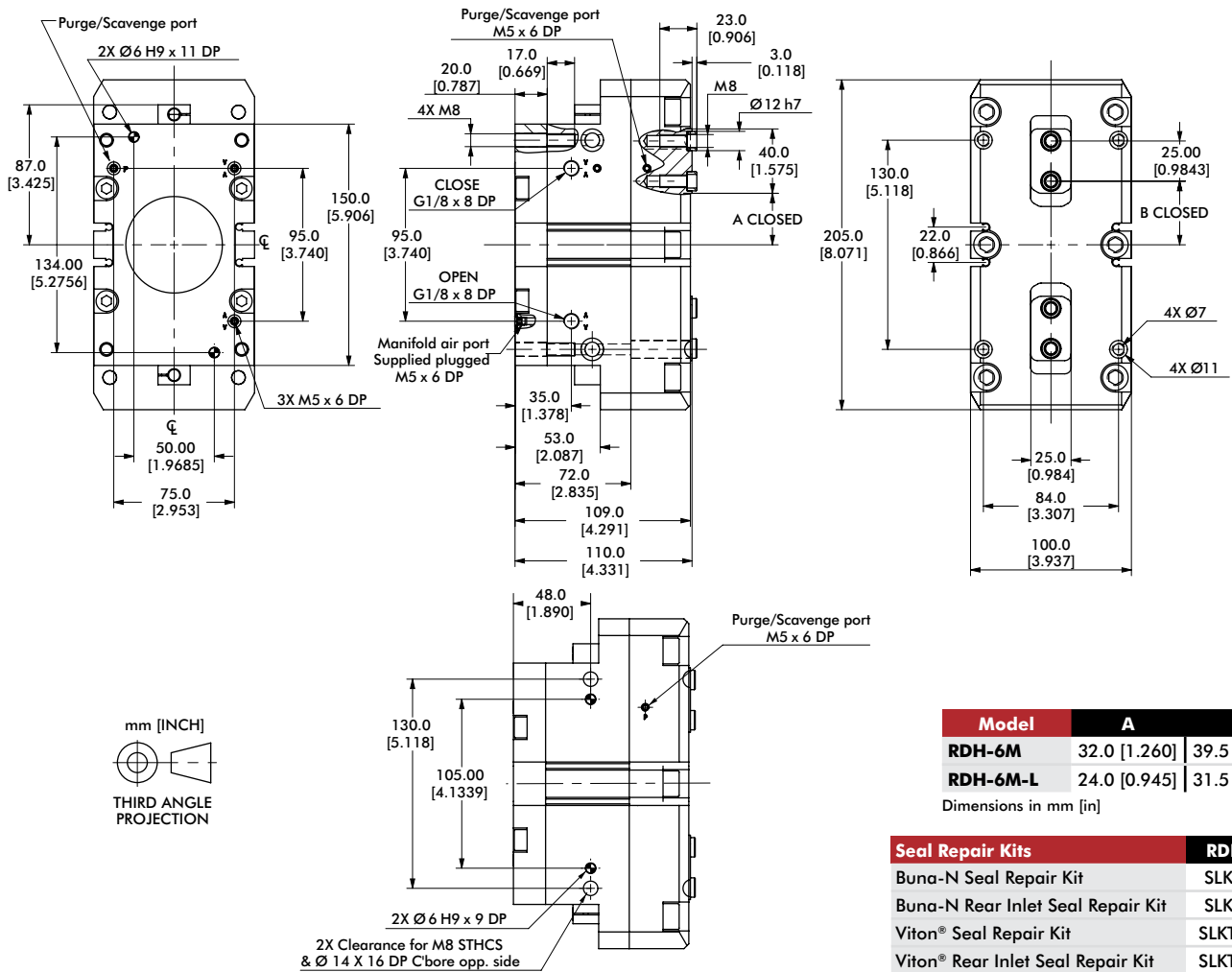

Loading Information

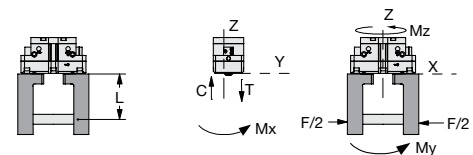
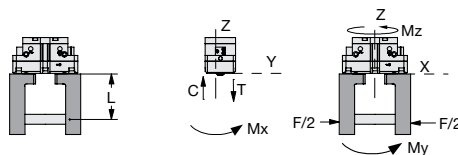
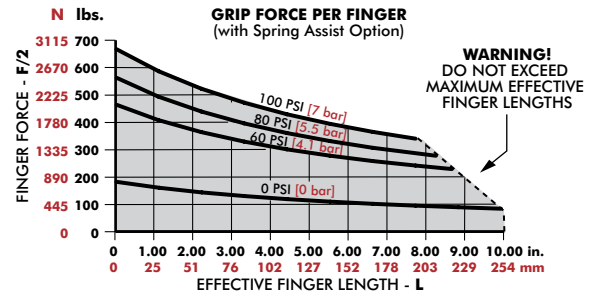
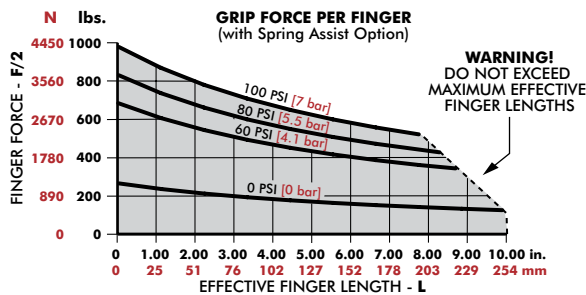

RDH-6M	Static	Dynamic
Maximum Tensile T	3463 N [779 lbs]	827 N [186 lbs]
Maximum Compressive C	4649 N [1045 lbs]	827 N [186 lbs]
Maximum Moment M_x	136 Nm [1204 in-lbs]	28 Nm [248 in-lbs]
Maximum Moment M_y	197 Nm [1744 in-lbs]	41 Nm [363 in-lbs]
Maximum Moment M_z	130 Nm [1151 in-lbs]	41 Nm [363 in-lbs]

†Capacities are per set of jaws and are not simultaneous

RDH-6M-L	Static	Dynamic
Maximum Tensile T	3089 N [694 lbs]	537 N [121 lbs]
Maximum Compressive C	4146 N [932 lbs]	537 N [121 lbs]
Maximum Moment M_x	121 Nm [1071 in-lbs]	18 Nm [159 in-lbs]
Maximum Moment M_y	157 Nm [1390 in-lbs]	24 Nm [212 in-lbs]
Maximum Moment M_z	103 Nm [912 in-lbs]	24 Nm [212 in-lbs]

†Capacities are per set of jaws and are not simultaneous

RDH-7M, -7M-L

2-Jaw General Industrial Grippers | Dimensions and Technical Specifications

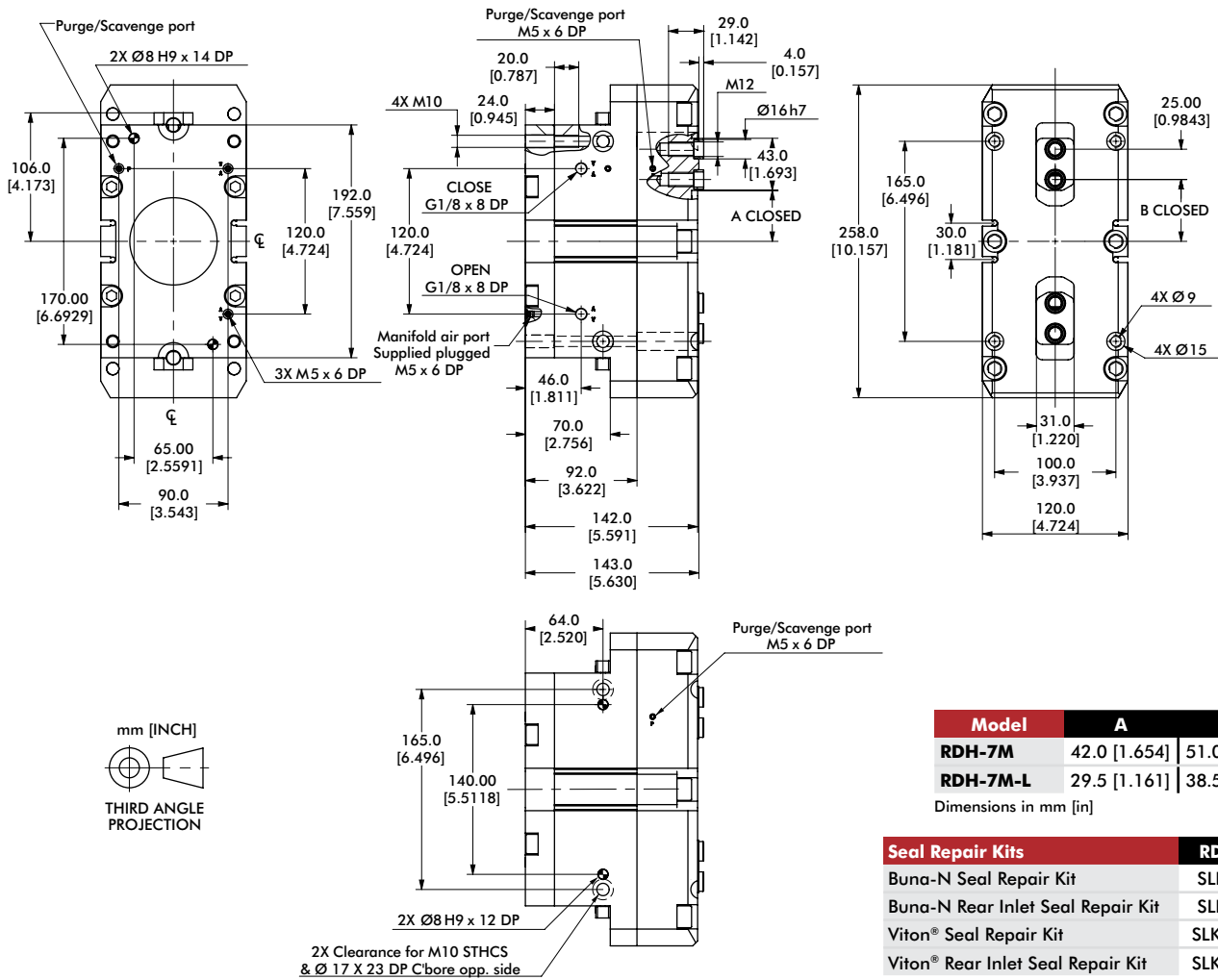

Loading Information

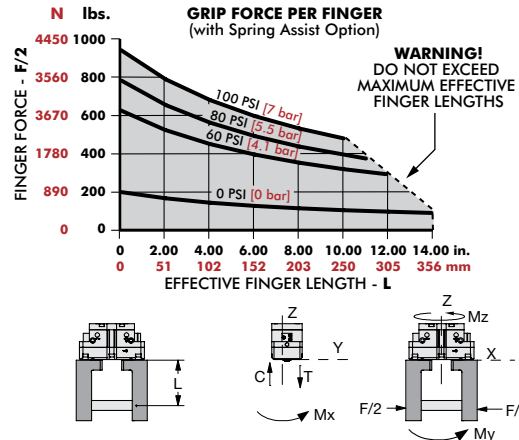
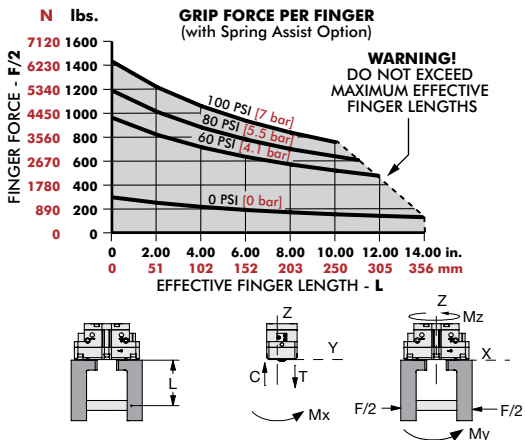

RDH-7M	Static	Dynamic
Maximum Tensile T	4505 N [1013 lbs]	1048 N [236 lbs]
Maximum Compressive C	5938 N [1335 lbs]	1048 N [236 lbs]
Maximum Moment M_x	167 Nm [1478 in-lbs]	36 Nm [319 in-lbs]
Maximum Moment M_y	238 Nm [2106 in-lbs]	51 Nm [451 in-lbs]
Maximum Moment M_z	161 Nm [1425 in-lbs]	51 Nm [451 in-lbs]

*Capacities are per set of jaws and are not simultaneous

RDH-7M-L	Static	Dynamic
Maximum Tensile T	3911 N [879 lbs]	678 N [152 lbs]
Maximum Compressive C	5155 N [1159 lbs]	678 N [152 lbs]
Maximum Moment M_x	145 Nm [1283 in-lbs]	23 Nm [204 in-lbs]
Maximum Moment M_y	179 Nm [1584 in-lbs]	29 Nm [257 in-lbs]
Maximum Moment M_z	122 Nm [1080 in-lbs]	29 Nm [257 in-lbs]

*Capacities are per set of jaws and are not simultaneous

RDH-8M, -8M-L

2-Jaw General Industrial Grippers | Dimensions and Technical Specifications

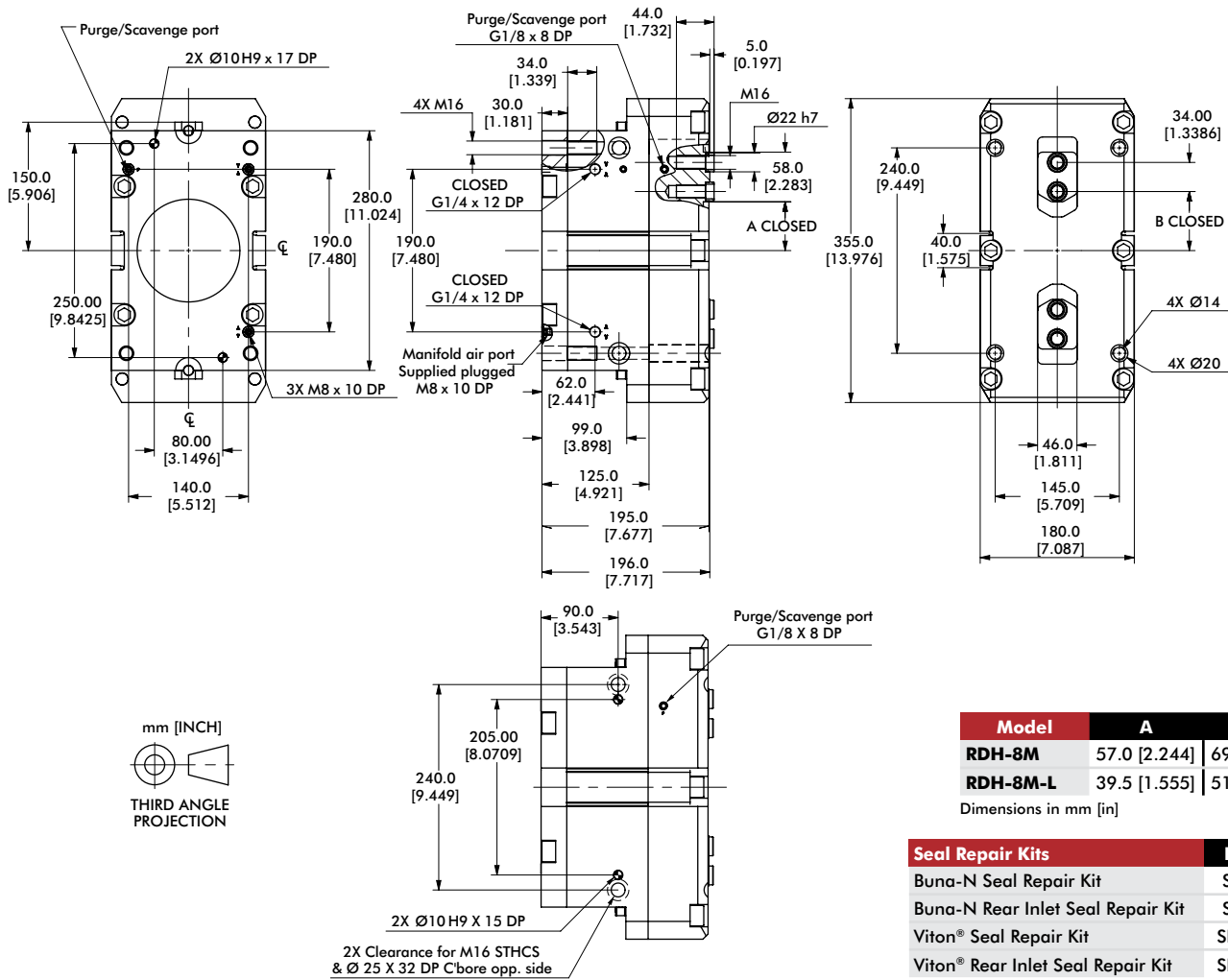

Loading Information

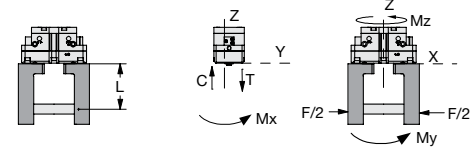
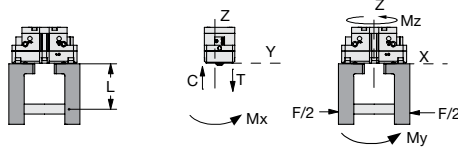
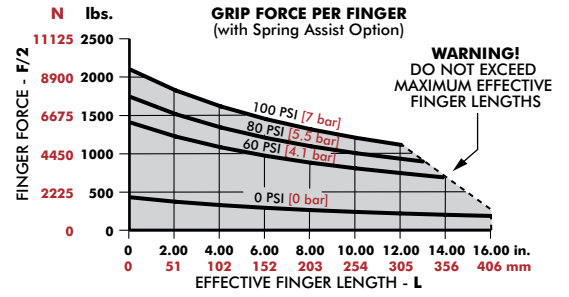
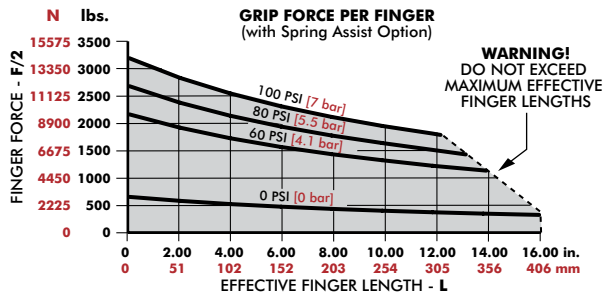

RDH-8M	Static	Dynamic
Maximum Tensile T	6863 N [1543 lbs]	1743 N [392 lbs]
Maximum Compressive C	8921 N [2006 lbs]	1743 N [392 lbs]
Maximum Moment M_x	379 Nm [3354 in-lbs]	84 Nm [743 in-lbs]
Maximum Moment M_y	481 Nm [4257 in-lbs]	107 Nm [947 in-lbs]
Maximum Moment M_x	301 Nm [2664 in-lbs]	107 Nm [947 in-lbs]

RDH-8M-L	Static	Dynamic
Maximum Tensile T	5906 N [1328 lbs]	1125 N [253 lbs]
Maximum Compressive C	7678 N [1726 lbs]	1125 N [253 lbs]
Maximum Moment M_x	326 Nm [2885 in-lbs]	54 Nm [478 in-lbs]
Maximum Moment M_y	357 Nm [3160 in-lbs]	59 Nm [522 in-lbs]
Maximum Moment M_x	223 Nm [1974 in-lbs]	59 Nm [522 in-lbs]

¹Capacities are per set of jaws and are not simultaneous

¹Capacities are per set of jaws and are not simultaneous