

CT/DCT & CT-RE/DCT-RE SERIES

Angular Grippers | Features and Benefits | How To Order

Features:

- 180° angular gripper jaw opening for direct feed systems
- Shielded design for working in dirty environments
- Spring assist option maintains grip in case of air pressure loss
- Adjustable 0 to 180° opening angle option.
- Side and bottom gripper mounting
- Multiple air ports, side and top air ports for easy installation

Applications:

- In-line conveying applications
- OEM pick and place machines
- End-of-arm tooling



How To Order

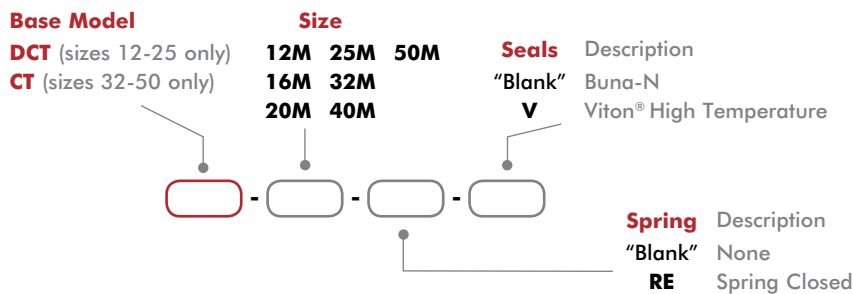

Accessories

Sensor Accessories	Model Numbers	Part Number	Qty/Unit
NPN Magneto Resistive Sensor with M8 Quick Disconnect	All Models	OHSN-017	1-2
PNP Magneto Resistive Sensor with M8 Quick Disconnect	All Models	OHSP-017	1-2
Inductive Sensor Mounting Kit (mounts 2 sensors)	See Datasheet		1
4mm NPN Inductive Sensor with M8 Quick Disconnect*	16M, 20M	OISN-014	1-2
4mm PNP Inductive Sensor M8 with Quick Disconnect*	16M, 20M	OISP-014	1-2
M8 NPN Inductive Sensor with M8 Quick Disconnect*	25M, 32M	OISN-011	1-2
M8 PNP Inductive Sensor with M8 Quick Disconnect*	25M, 32M	OISP-011	1-2
M12 NPN Inductive Sensor with M12 Quick Disconnect*	40M, 50M	OISN-017	1-2
M12 PNP Inductive Sensor with M12 Quick Disconnect*	40M, 50M	OISP-017	1-2
M8 Quick Disconnect 2 Meter Cable Length*	All Models	CABL-010	1-2
M8 Quick Disconnect 5 Meter Cable Length*	All Models	CABL-013	1-2
M12 Quick Disconnect 2 Meter Cable Length*	All Models	CABL-014	1-2
M12 Quick Disconnect 5 Meter Cable Length*	All Models	CABL-018	1-2

Pneumatic Accessories	Model Numbers	Part Number	Qty/Unit
Adjustable Flow Control-M5 Elbow-6mm OD Push-in	12M, 16M, 20M, 25M, 32M	VLVF-008	1-2
Adjustable Flow Control-G1/8 Elbow-6mm OD Push-in	40M, 50M	VLVF-005	1-2

*Sensor and cable sold separately.

CT/DCT & CT-RE/DCT-RE SERIES

Angular Grippers | Technical Specifications

Specifications	Units	12M	12M-RE	16M	16M-RE	20M	20M-RE	25M	25M-RE
Total Rated Grip Force F @ 100 psi [7 bar]	N [lb]	32 [7.2]	40 [9]	70 [16]	87 [19]	112 [25]	141 [32]	157 [35]	199 [45]
Stroke (degrees per finger)		90° stroke for each finger							
Weight	kg [lbs]	0.09 [0.20]	0.12 [0.26]	0.16 [0.35]	0.20 [0.44]	0.28 [0.62]	0.33 [0.73]	0.49 [1.08]	0.57 [1.26]
Pressure Range w/o Spring	bar [psia]	3-7 [40-100] CT/DCT							
Pressure Range w/ Spring	bar [psi]	4-7 [60-100] CT-RE/DCT-RE							
Ingress Protection Class (IP)		IP43							
Displacement	cm ³ [in ³]	1.92 [0.117]		4.12 [0.251]		7.92 [0.483]		14.9 [0.909]	
Temperature Range (Buna-N seals)	°C [°F]	-35°~80° [-30°~180°]							
Temperature Range (Viton® seals)	°C [°F]	-30°~150° [-20°~300°]							
Actuation (open)	sec	0.06	0.08	0.13	0.15	0.16	0.20	0.21	0.25
Actuation (close)	sec	0.06	0.05	0.13	0.12	0.16	0.14	0.21	0.19
Accuracy	mm [in]	±0.07 [±0.0028]				±0.08 [±0.003]			
Repeatability	mm [in]	±0.05 [±0.002]							
Valve to Actuate Double Acting		4-way, 2-position CT/DCT							
Valve to Actuate Double Acting Spring Assist		4-way, 2-position CT-RE/DCT-RE							
Valve to Actuate Single Acting		3-way, 2-position CT-RE/DCT-RE							

Specifications	Units	32M	32M-RE	40M	40M-RE	50M	50M-RE
Total Rated Grip Force F @ 100 psi [7 bar]	N [lb]	272 [61]	353 [79]	446 [100]	592 [133]	651 [146]	893 [201]
Stroke (degrees per finger)		90° stroke for each finger					
Weight	kg [lbs]	0.72 [1.59]	0.83 [1.83]	1.18 [2.60]	1.39 [3.06]	1.82 [4.01]	2.21 [4.87]
Pressure Range w/o Spring	bar [psia]	3-7 [40-100] CT/DCT					
Pressure Range w/ Spring	bar [psi]	4-7 [60-100] CT-RE/DCT-RE					
Ingress Protection Class (IP)		IP43					
Displacement	cm ³ [in ³]	28.6 [1.745]		52 [3.173]		92 [5.614]	
Temperature Range (Buna-N seals)	°C [°F]	-35°~80° [-30°~180°]					
Temperature Range (Viton® seals)	°C [°F]	-30°~150° [-20°~300°]					
Actuation (open)	sec	0.29	0.35	0.41	0.47	0.46	0.54
Actuation (close)	sec	0.29	0.26	0.41	0.38	0.46	0.42
Accuracy	mm [in]	±0.08 [±0.003]			±0.09 [±0.0036]		
Repeatability	mm [in]	±0.05 [±0.002]					
Valve to Actuate Double Acting		4-way, 2-position CT/DCT					
Valve to Actuate Double Acting Spring Assist		4-way, 2-position CT-RE/DCT-RE					
Valve to Actuate Single Acting		3-way, 2-position CT-RE/DCT-RE					

Angular Grippers | Dimensions and Technical Specifications

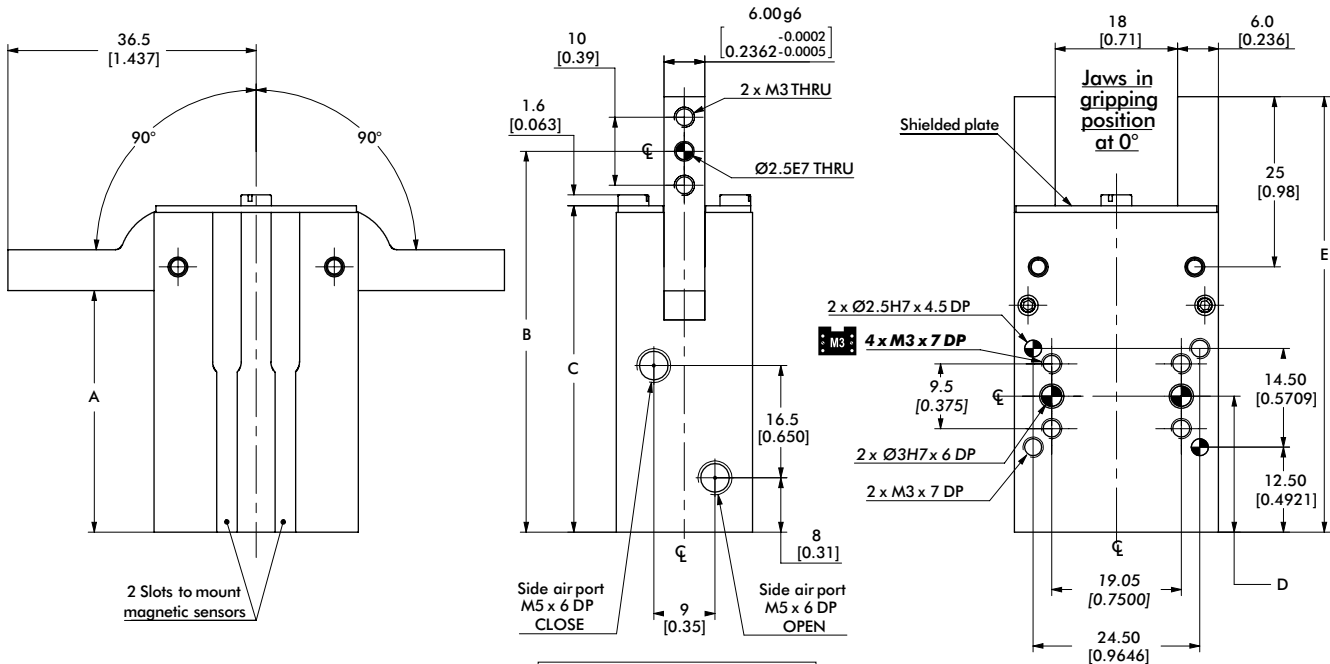

NOTE: Jaws have to be designed for a 0° gripping position (parallel jaws). Jaws will close 1.5° past parallel. To limit shocks at the end of an opening or closing stroke, it is highly recommended to design jaws with minimal inertia (as light and short as possible). Flow Controls make it possible to reduce the rotation speed and are highly recommended.

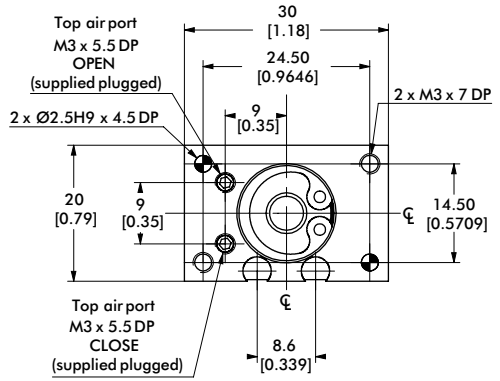
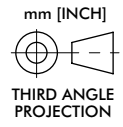
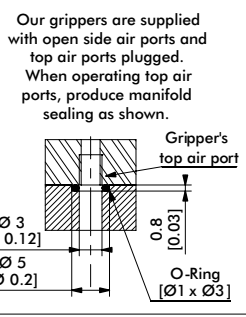

Model	A	B	C	D	E
DCT-12	35.5 [1.398]	56.00 [2.2047]	48 [1.89]	20.00 [0.7874]	64 [2.52]
DCT-12-RE	51.5 [2.028]	72.00 [2.8346]	64 [2.52]	35.00 [1.3780]	80 [3.15]

Dimensions in mm [in]

Mounting Accessories	Order #
Adjustment Stop Kit (1 shielded plate, 1 stop)	KP-DCT12-BR
Seal Repair Kits	Order #
Buna-N Seal Repair Kit	SLKT-159
Viton® Seal Repair Kit	SLKT-159V

Loading Information

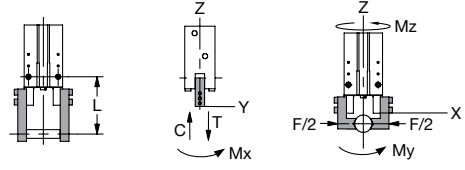
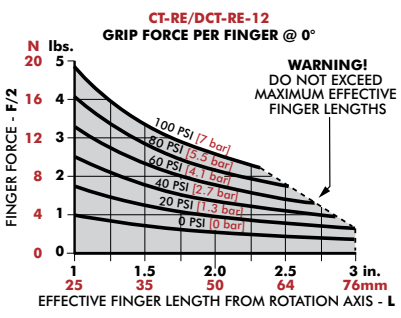
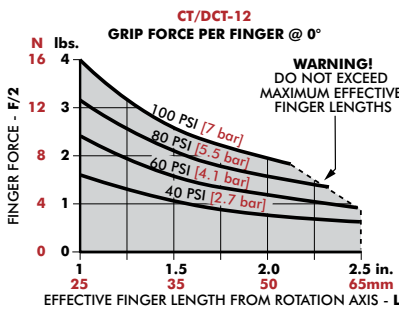

Static	
Maximum Tensile T	47 N [11 lbs]
Maximum Compressive C	47 N [11 lbs]
Maximum Moment M_x	1.1 Nm [10 in-lbs]
Maximum Moment M_y	1.1 Nm [10 in-lbs]
Maximum Moment M_z	1.1 Nm [10 in-lbs]

*Capacities are per set of jaws and are not simultaneous

Angular Grippers | Dimensions and Technical Specifications

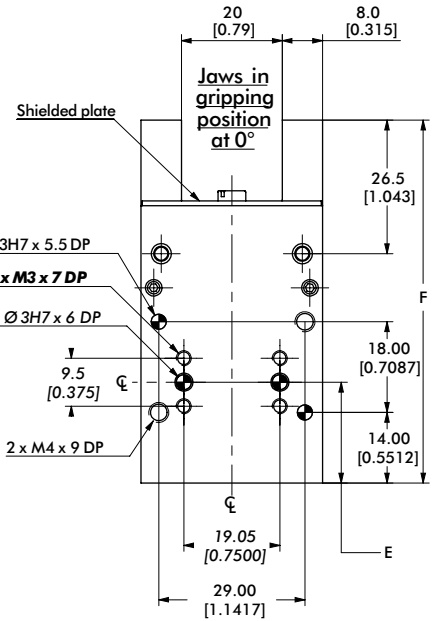
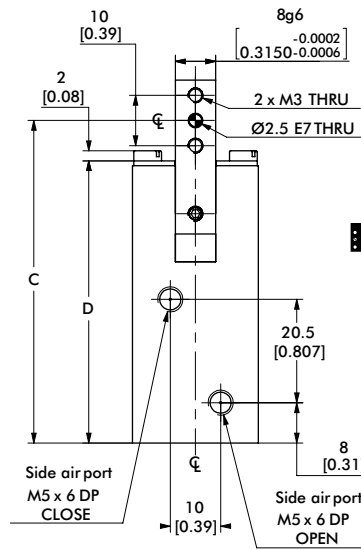
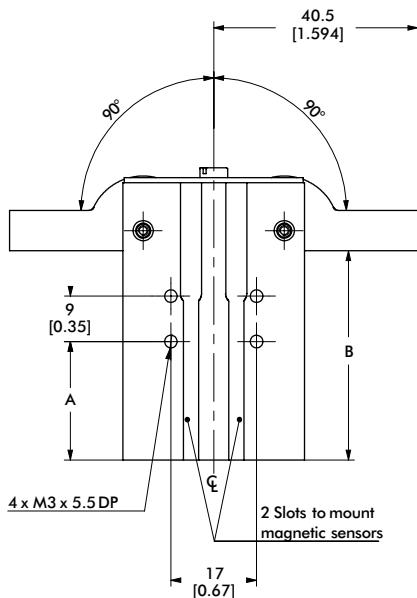

NOTE: Jaws have to be designed for a 0° gripping position (parallel jaws). Jaws will close 1.5° past parallel. To limit shocks at the end of an opening or closing stroke, it is highly recommended to design jaws with minimal inertia (as light and short as possible). Flow Controls make it possible to reduce the rotation speed and are highly recommended.

Our grippers are supplied with open side air ports and top air ports plugged. When operating top air ports, produce manifold sealing as shown.

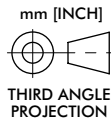
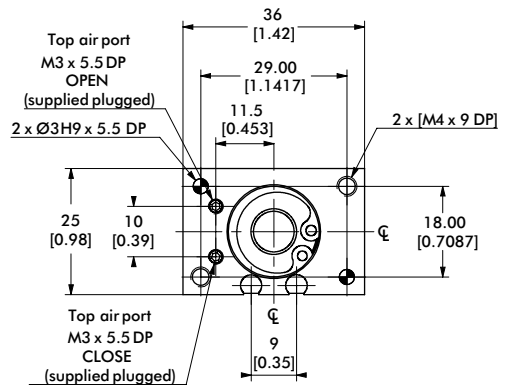
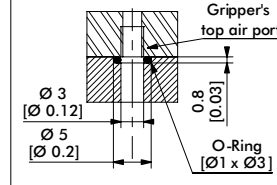

Model	A	B	C	D	E	F
DCT-16	23.5 [0.925]	41.5 [1.634]	64.00 [2.5197]	56 [2.20]	20.00 [0.7874]	72 [2.83]
DCT-16-RE	38.5 [1.516]	56.5 [2.224]	79.00 [3.1102]	71 [2.80]	35.00 [1.3780]	87 [3.43]

Dimensions in mm [in]

Mounting Accessories

Order #
Inductive Sensor Mounting Kit (mounts 2 sensors)
Adjustment Stop Kit (1 shielded plate, 1 stop)

Seal Repair Kits

Order #
Buna-N Seal Repair Kit
Viton® Seal Repair Kit

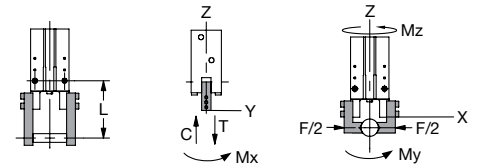
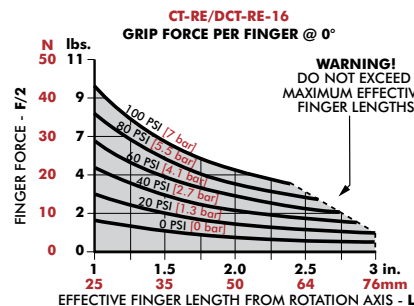
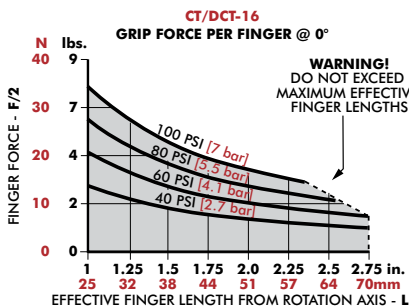

Static	
Maximum Tensile T	90 N [20 lbs]
Maximum Compressive C	90 N [20 lbs]
Maximum Moment M_x	2.9 Nm [26 in-lbs]
Maximum Moment M_y	2.9 Nm [26 in-lbs]
Maximum Moment M_z	2.9 Nm [26 in-lbs]

*Capacities are per set of jaws and are not simultaneous

Angular Grippers | Dimensions and Technical Specifications

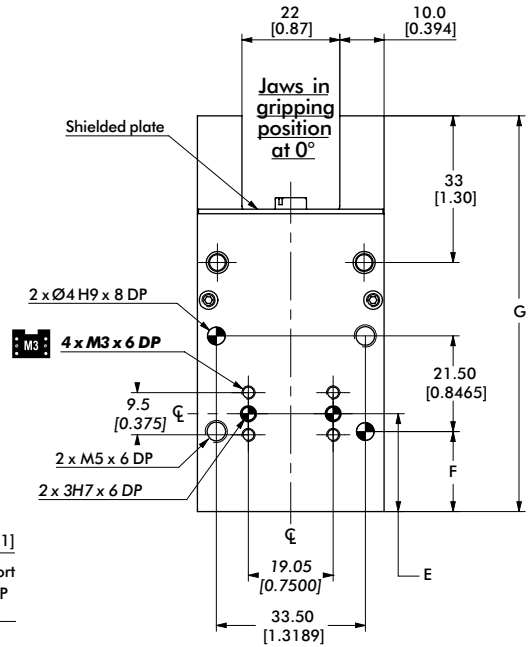
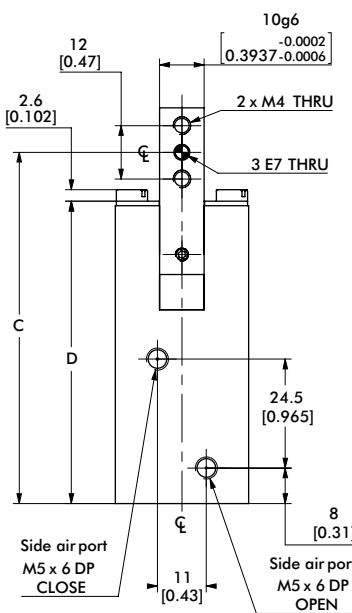
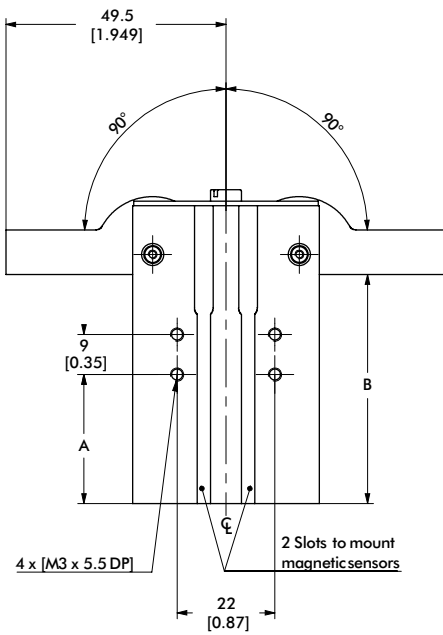

NOTE: Jaws have to be designed for a 0° gripping position (parallel jaws). Jaws will close 1.5° past parallel. To limit shocks at the end of an opening or closing stroke, it is highly recommended to design jaws with minimal inertia (as light and short as possible). Flow Controls make it possible to reduce the rotation speed and are highly recommended.

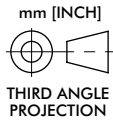
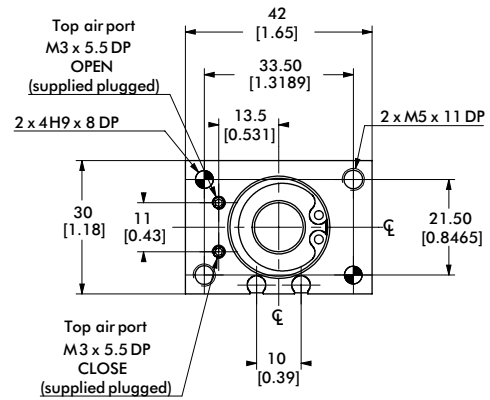
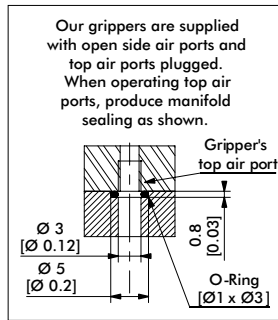

Model	A	B	C	D	E	F	G
DCT-20	29 [1.14]	51.5 [2.028]	79.00 [3.1102]	68 [2.68]	22.00 [0.8661]	18.00 [0.7087]	89 [3.50]
DCG/CT-20-RE	47 [1.85]	66.5 [2.618]	94.00 [3.7008]	83 [3.27]	39.00 [1.5354]	20.00 [0.7874]	104 [4.09]

Dimensions in mm [in]

Mounting Accessories	Order #
Inductive Sensor Mounting Kit (mounts 2 sensors)	SDCT-16-20
Adjustment Stop Kit (1 shielded plate, 1 stop)	KP-DCT20-BR
Seal Repair Kits	Order #
Buna-N Seal Repair Kit	SLKT-161
Viton® Seal Repair Kit	SLKT-161V

Loading Information

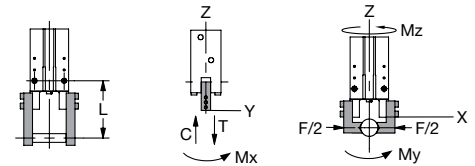
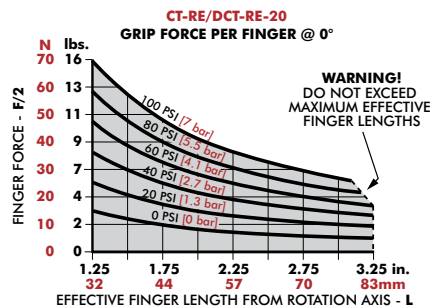
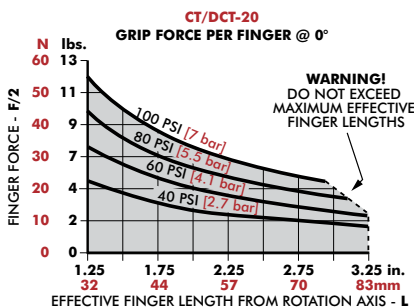

Static	
Maximum Tensile T	150 N [34 lbs]
Maximum Compressive C	150 N [34 lbs]
Maximum Moment M_x	6 Nm [53 in-lbs]
Maximum Moment M_y	6 Nm [53 in-lbs]
Maximum Moment M_z	6 Nm [53 in-lbs]

¹Capacities are per set of jaws and are not simultaneous

Angular Grippers | Dimensions and Technical Specifications

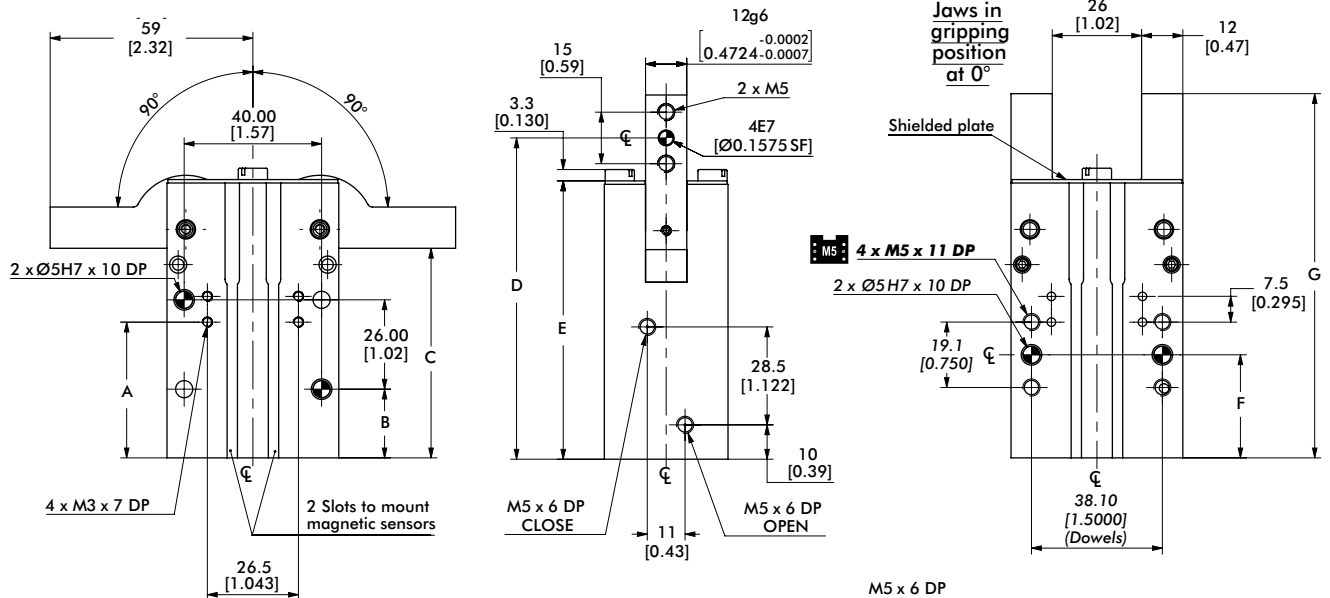

NOTE: Jaws have to be designed for a 0° gripping position (parallel jaws). Jaws will close 1.5° past parallel. To limit shocks at the end of an opening or closing stroke, it is highly recommended to design jaws with minimal inertia (as light and short as possible). Flow Controls make it possible to reduce the rotation speed and are highly recommended.

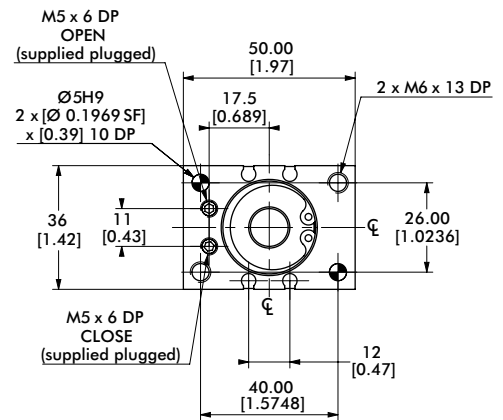
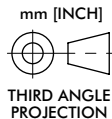
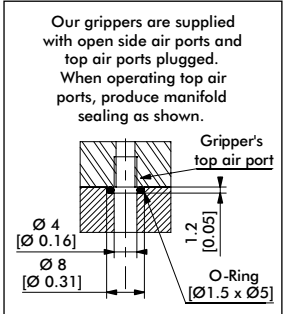

Model	A	B	C	D	E	F	G
DCT-25	39.5 [1.555]	20.00 [0.79]	61 [2.40]	93.50 [3.6811]	81 [3.19]	30.00 [1.1811]	106 [4.17]
DCT-25-RE	60.5 [2.382]	25.00 [0.98]	82 [3.23]	114.50 [4.5079]	102 [4.02]	51.00 [2.0079]	127 [5.00]

Dimensions in mm [in]

Mounting Accessories	Order #
Inductive Sensor Mounting Kit (mounts 2 sensors)	SDCT-25-32
Adjustment Stop Kit (1 shielded plate, 1 stop)	KP-DCT25-BR
Seal Repair Kits	Order #
Buna-N Seal Repair Kit	SLKT-162
Viton® Seal Repair Kit	SLKT-162V

Loading Information

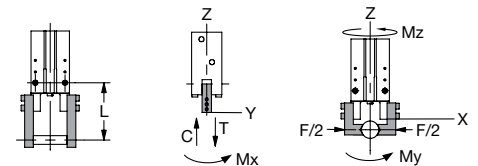
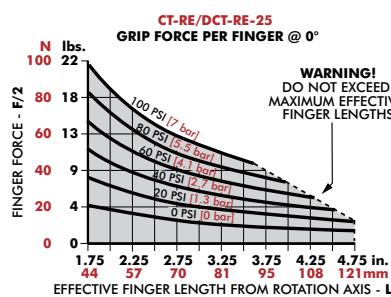
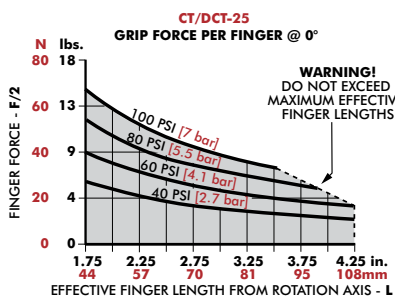

Static	
Maximum Tensile T	205 N [46 lbs]
Maximum Compressive C	205 N [46 lbs]
Maximum Moment M_x	10 Nm [89 in-lbs]
Maximum Moment M_y	10 Nm [89 in-lbs]
Maximum Moment M_z	10 Nm [89 in-lbs]

*Capacities are per set of jaws and are not simultaneous

CT-32/ -32-RE

Angular Grippers | Dimensions and Technical Specifications

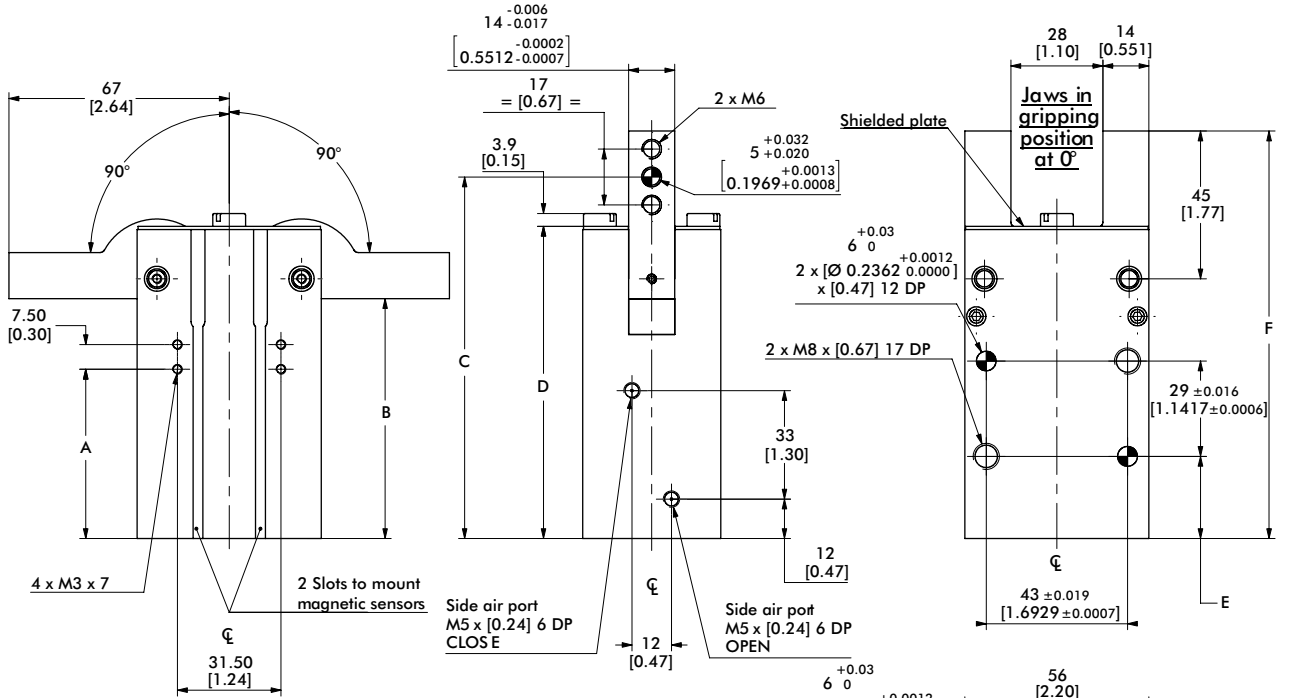

NOTE: Jaws have to be designed for a 0° gripping position (parallel jaws). Jaws will close 1.5° past parallel. To limit shocks at the end of an opening or closing stroke, it is highly recommended to design jaws with minimal inertia (as light and short as possible). Flow Controls make it possible to reduce the rotation speed and are highly recommended.

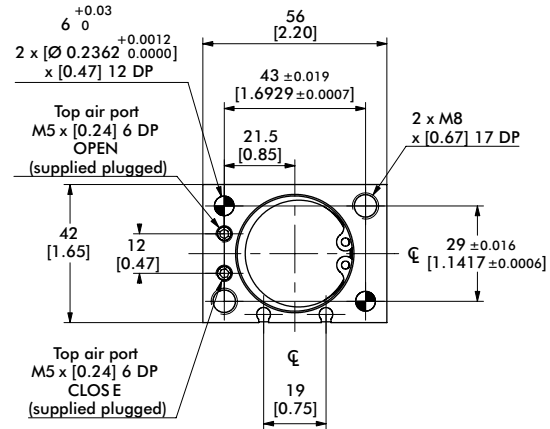
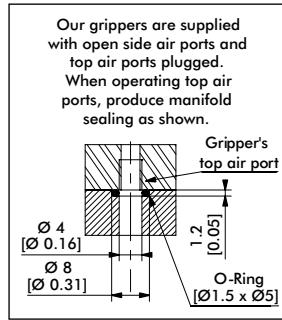
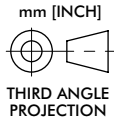

Model	A	B	C	D	E	F
CT-32	51.50 [2.03]	73 [2.87]	110 [4.3307]	95 [3.74]	25 [0.9843]	124 [4.88]
CT-32-RE	72.50 [2.85]	94 [3.70]	131 [5.1575]	116 [4.57]	30 [1.811]	145 [5.71]

Dimensions in mm [in]

Mounting Accessories	Order #
Inductive Sensor Mounting Kit (mounts 2 sensors)	SDCT-25-32
Adjustment Stop Kit (1 shielded plate, 1 stop)	KP-CT32-BR
Seal Repair Kits	Order #
Buna-N Seal Repair Kit	SLKT-163
Viton® Seal Repair Kit	SLKT-163V

Loading Information

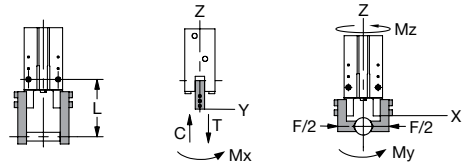
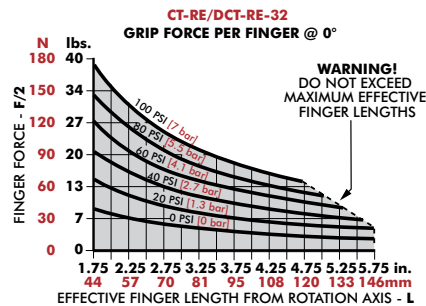
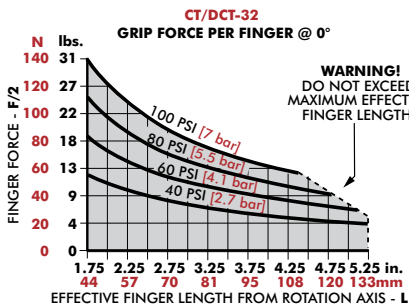

	Static
Maximum Tensile T	288 N [65 lbs]
Maximum Compressive C	288 N [65 lbs]
Maximum Moment M _x	16 Nm [142 in-lbs]
Maximum Moment M _y	16 Nm [142 in-lbs]
Maximum Moment M _z	16 Nm [142 in-lbs]

^cCapacities are per set of jaws and are not simultaneous

Angular Grippers | Dimensions and Technical Specifications

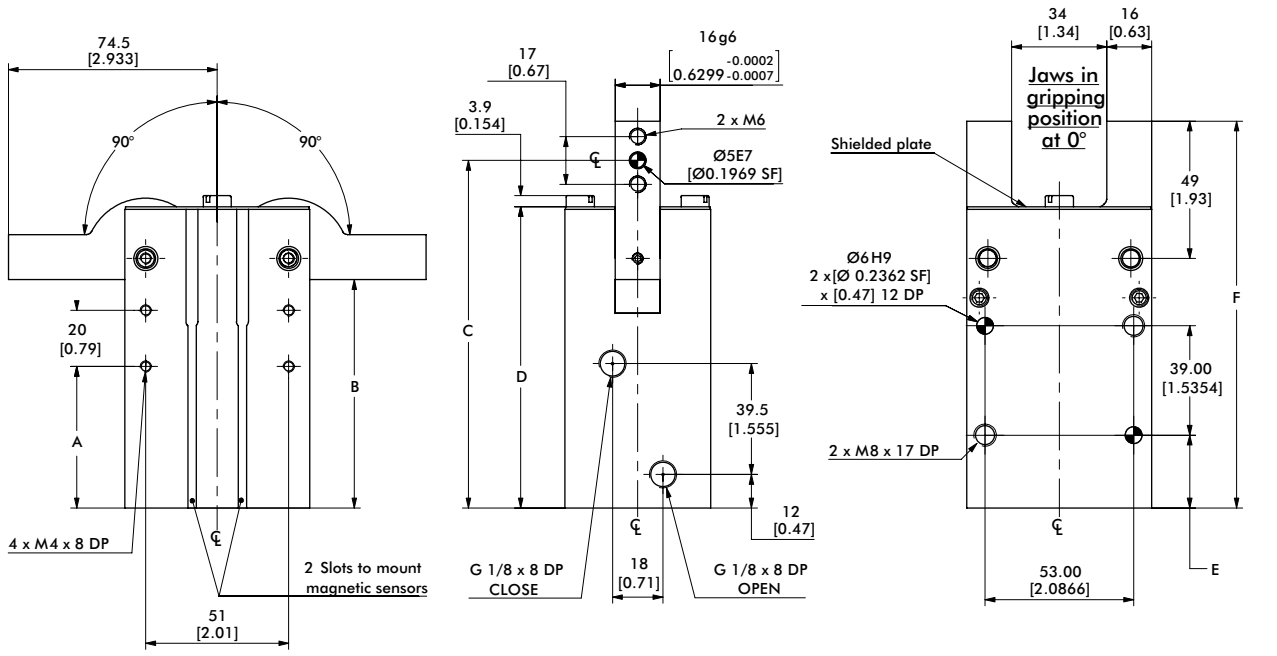

NOTE: Jaws have to be designed for a 0° gripping position (parallel jaws). Jaws will close 1.5° past parallel. To limit shocks at the end of an opening or closing stroke, it is highly recommended to design jaws with minimal inertia (as light and short as possible). Flow Controls make it possible to reduce the rotation speed and are highly recommended.

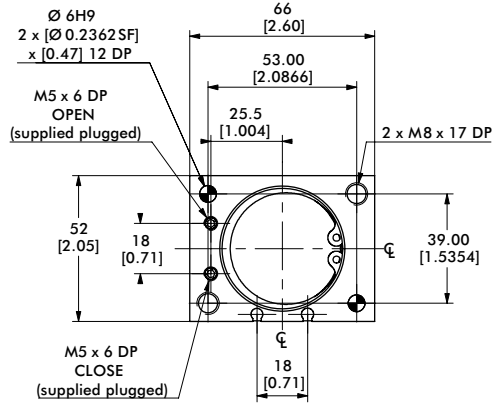
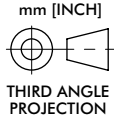
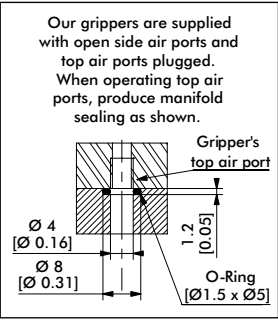

Model	A	B	C	D	E	F
CT-40	50.5 [1.988]	81.5 [3.209]	124.00 [4.8819]	107.5 [4.232]	26.00 [1.0236]	138 [5.43]
CT-40-RE	78 [3.07]	109 [4.29]	151.50 [5.9646]	135 [5.31]	32.00 [1.2598]	165.5 [6.516]

Dimensions in mm [in]

Mounting Accessories	Order #
Inductive Sensor Mounting Kit (mounts 2 sensors)	SDCT-40-63
Adjustment Stop Kit (1 shielded plate, 1 stop)	KP-CT40-BR
Seal Repair Kits	Order #
Buna-N Seal Repair Kit	SLKT-164
Viton® Seal Repair Kit	SLKT-164V

Loading Information

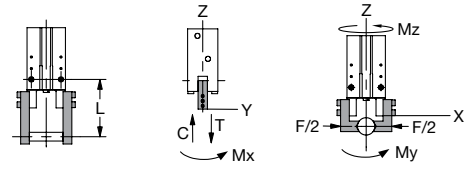
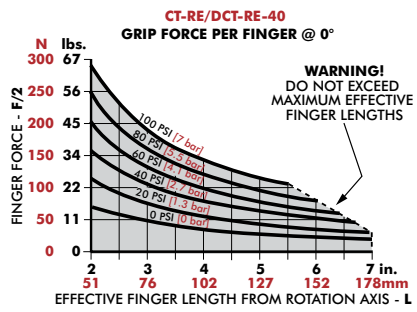
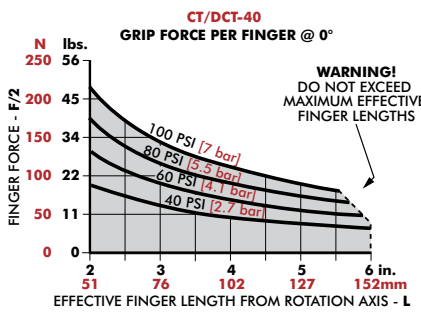

	Static
Maximum Tensile T	420 N [94 lbs]
Maximum Compressive C	420 N [94 lbs]
Maximum Moment M_x	22 Nm [195 in-lbs]
Maximum Moment M_y	22 Nm [195 in-lbs]
Maximum Moment M_z	22 Nm [195 in-lbs]

*Capacities are per set of jaws and are not simultaneous

CT-50/ -50-RE

Angular Grippers | Dimensions and Technical Specifications

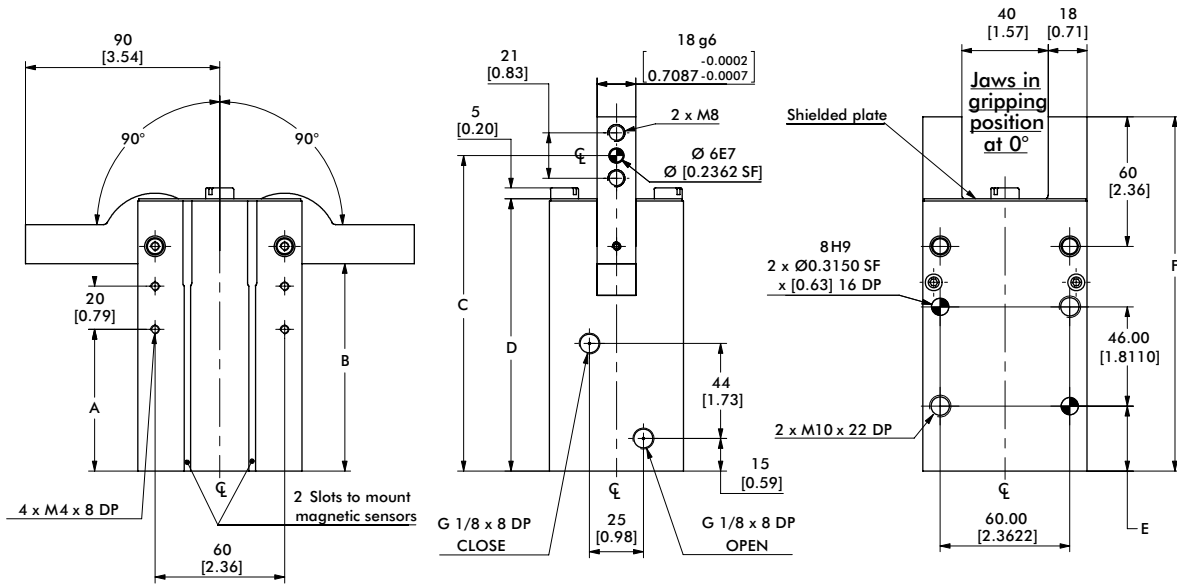

NOTE: Jaws have to be designed for a 0° gripping position (parallel jaws). Jaws will close 1.5° past parallel. To limit shocks at the end of an opening or closing stroke, it is highly recommended to design jaws with minimal inertia (as light and short as possible). Flow Controls make it possible to reduce the rotation speed and are highly recommended.

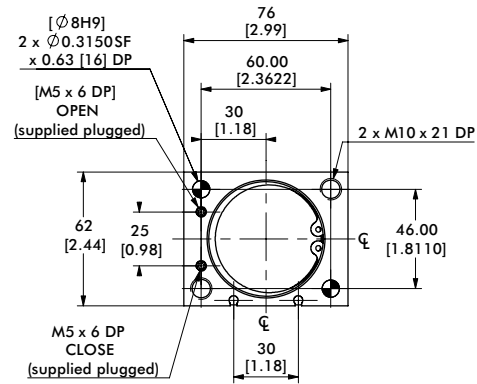
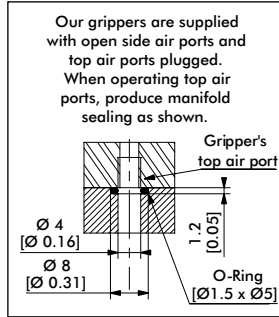
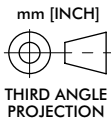

Model	A	B	C	D	E	F
CT-50	65.5 [2.579]	96 [3.78]	146.00 [5.7480]	126 [4.96]	30.00 [1.1811]	164 [6.46]
CT-50-RE	102.50 [4.035]	133 [5.24]	183.00 [7.2047]	163 [6.42]	40.00 [1.5748]	201 [7.91]

Dimensions in mm [in]

Mounting Accessories	Order #
Inductive Sensor Mounting Kit (mounts 2 sensors)	SDCT-40-63
Adjustment Stop Kit (1 shielded plate, 1 stop)	KP-CT50-BR
Seal Repair Kits	Order #
Buna-N Seal Repair Kit	SLKT-165
Viton® Seal Repair Kit	SLKT-165V

Loading Information

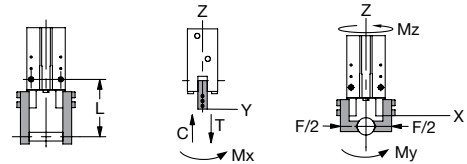
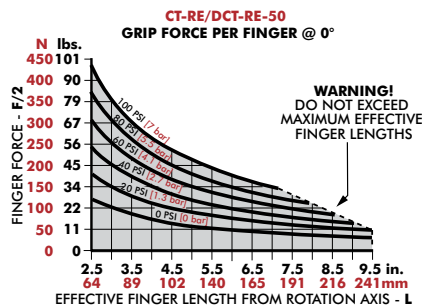
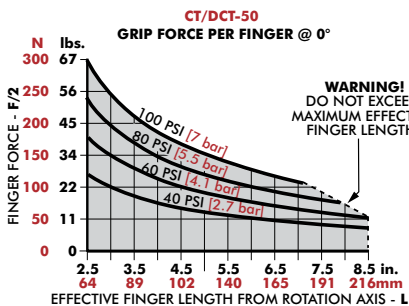

	Static
Maximum Tensile T	490 N [110 lbs]
Maximum Compressive C	490 N [110 lbs]
Maximum Moment M_x	30 Nm [266 in-lbs]
Maximum Moment M_y	30 Nm [266 in-lbs]
Maximum Moment M_z	30 Nm [266 in-lbs]

ⁱCapacities are per set of jaws and are not simultaneous