

PGM SERIES

Parallel Gear Servo Positioner | Table of Contents



PGM40

Features:

Destaco's **CAMCO PGM Parallel Gear Reducers** is a precision servo reducer with parallel cam mechanism.

Light, accurate, and high cost performance offers easy to use character for wide range of applications. It features a pre-loaded precision parallel cam, low input inertia, through-hole design, integrated sealed tapered bearings, high performance grease and several motor options with integrated motor clamp system for easy fitting.

Table of Contents

IN-SRV-#

Features & Benefits	20
How to Order	21
Specifications	22
PGM40	23

Precision Servo Reducer with Pre-loaded Parallel Cam Structure

The PGM parallel cam mechanism with pre-loaded structure offers accurate and rigid indexing performance. It is designed for low input inertia and offers greater servo performance through a wide variety of motor options.

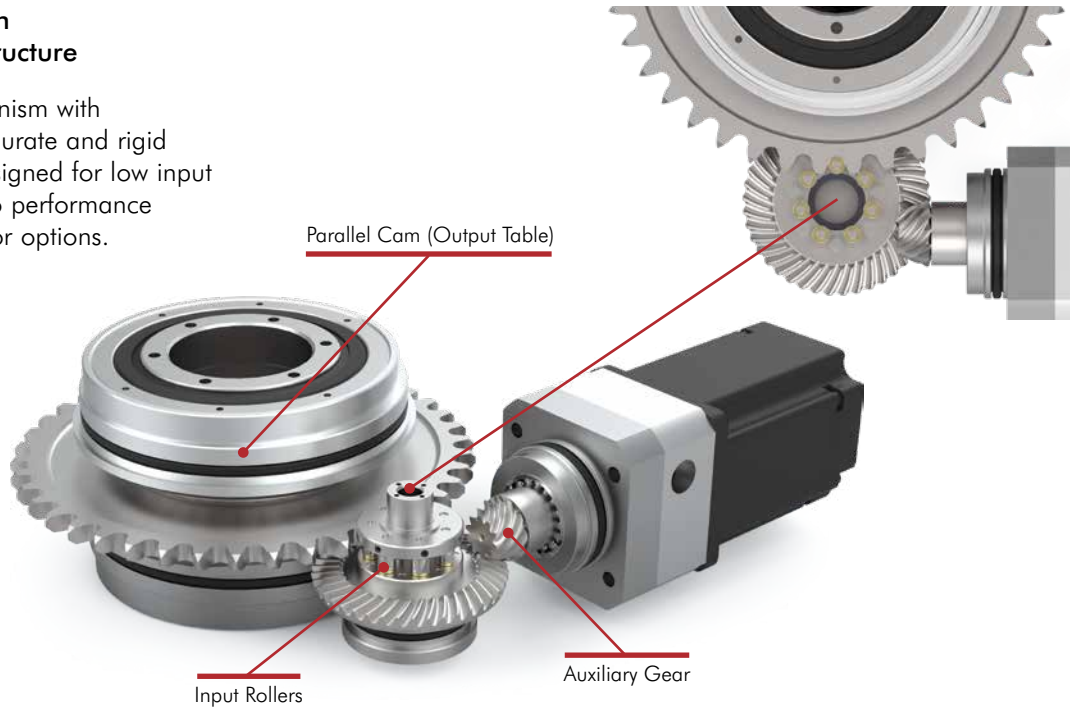

Thru-hole Design

Large central opening through the center of the output shaft structure is suitable for wiring and piping.



Integrated Motor Clamp System

The PGM offers a wide-variety of motor options that easily attach through the use of an integrated motor clamp.

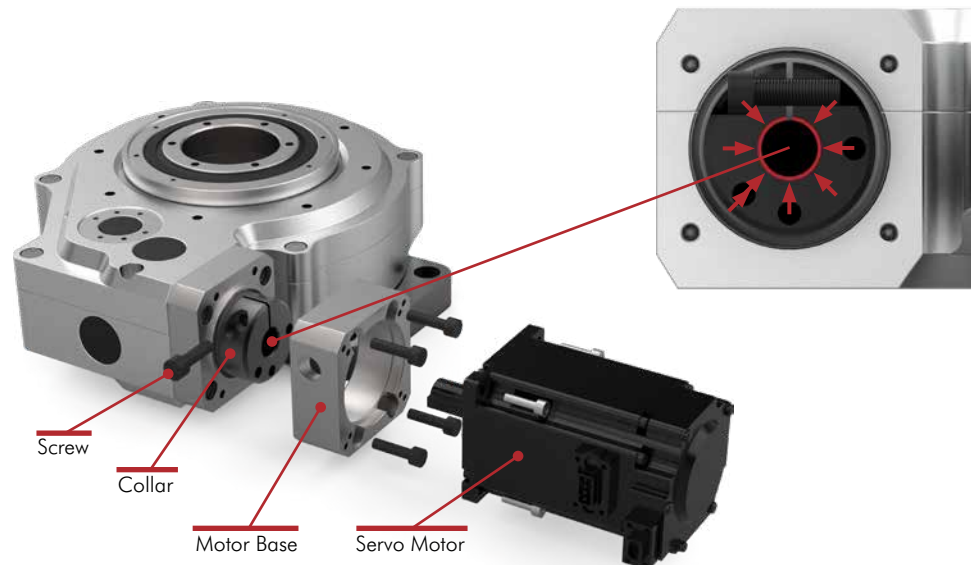

PGM SERIES

Parallel Gear Servo Positioner | How To Order

Parallel Gear Reducer Base Unit

PGM Series units can be interfaced with wide variety of servo motor manufacturers. Use the MI code tables to identify the supported motors for the PGM unit. Motors are ordered separately using the tables below.



PGM40 with Auxiliary Mounting Bracket. Motor not shown.

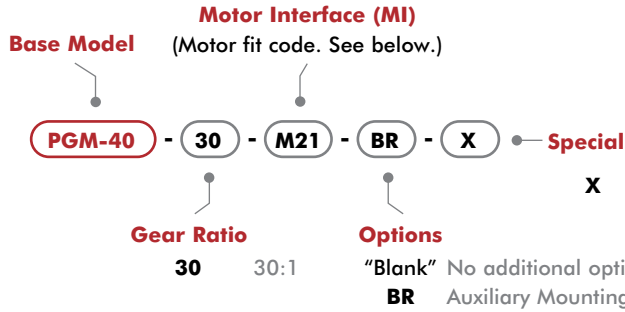

Make / Series	Model	mm [in]	kW [HP]	MI
Panasonic	A5 MSMD04	50 [1.97]	0,4 [0.54]	M21
	A5 MSME04	50 [1.97]	0,4 [0.54]	M21
	A5 MHMD04	50 [1.97]	0,4 [0.54]	M21
	A6 MSMF04	50 [1.97]	0,4 [0.54]	M21
	A6 MHMF04	50 [1.97]	0,4 [0.54]	M21

Make / Series	Model	mm [in]	kW [HP]	MI
ABB	ESM06X-201-302	50 [1.97]	0,2 [0.27]	M22
	ESM06X-401-302	50 [1.97]	0,4 [0.54]	M22
FANUC	β βiS1/6000	50 [1.97]	0,5 [0.67]	M22
	SV SV-M020	50 [1.97]	0,2 [0.27]	M22
Keyence	SV SV-M040	50 [1.97]	0,4 [0.54]	M22
	SV2 SV2-M020	50 [1.97]	0,2 [0.27]	M22
	SV2 SV2-M040	50 [1.97]	0,4 [0.54]	M22
Mitsubishi	J3 HF-KP23	50 [1.97]	0,2 [0.27]	M22
	J3 HF-KP43	50 [1.97]	0,4 [0.54]	M22
	J3 HF-MP23	50 [1.97]	0,2 [0.27]	M22
	J3 HF-MP43	50 [1.97]	0,4 [0.54]	M22
	J4 HG-KR23	50 [1.97]	0,2 [0.27]	M22
	J4 HG-KR43	50 [1.97]	0,4 [0.54]	M22
	J4 HG-MR23	50 [1.97]	0,2 [0.27]	M22
Sanyo	R2 R2AA06020F	50 [1.97]	0,2 [0.27]	M22
	R2 R2AA06040F	50 [1.97]	0,4 [0.54]	M22
	R2 R2AA06040H	50 [1.97]	0,4 [0.54]	M22
Yaskawa	Σ5 SGMAV-02A	50 [1.97]	0,2 [0.27]	M22
	Σ5 SGMAV-04A	50 [1.97]	0,4 [0.54]	M22
	Σ5 SGMAV-06A	50 [1.97]	0,55 [0.74]	M22
	Σ5 SGMJV-02A	50 [1.97]	0,2 [0.27]	M22
	Σ5 SGMJV-04A	50 [1.97]	0,4 [0.54]	M22
	Σ5 SGMJV-06A	50 [1.97]	0,6 [0.80]	M22
	Σ7 SGM7J-02A	50 [1.97]	0,2 [0.27]	M22
	Σ7 SGM7J-04A	50 [1.97]	0,4 [0.54]	M22
	Σ7 SGM7J-06A	50 [1.97]	0,6 [0.80]	M22
	Σ7 SGM7A-02A	50 [1.97]	0,2 [0.27]	M22
Σ7 SGM7A-04A	50 [1.97]	0,4 [0.54]	M22	
Σ7 SGM7A-06A	50 [1.97]	0,6 [0.80]	M22	

Easily Integrates with a Variety of Servo Motor Manufacturers

ABB
FANUC
Mitsubishi
Sanyo

Allen Bradley
Keyence
Panasonic
Yaskawa

□ = Motor Frame Size

Make / Series	Model	mm [in]	kW [HP]	MI
Allen Bradley	VPL VPL-A0632F	55 [2.17]	0,39 [0.52]	M23
	VPL VPL-B0632F	55 [2.17]	0,37 [0.50]	M23
	VPL VPL-B0632T	55 [2.17]	0,54 [0.72]	M23

Make / Series	Model	mm [in]	kW [HP]	MI
Allen Bradley	VPL VPL-A0752C	70 [2.76]	0,49 [0.66]	M24
	VPL VPL-A0752E	70 [2.76]	0,66 [0.89]	M24
	VPL VPL-B0752E	70 [2.76]	0,67 [0.90]	M24
	VPL VPL-B0752F	70 [2.76]	0,8 [1.07]	M24
	VPL VPL-B0752M	70 [2.76]	0,81 [1.09]	M24

Motor Interface (MI) [in] mm						
MI	a	b	c	d	e	f
M21	[0.91-1.22]	[≤0.16]	[1.97]	[≤0.20]	[2.76]	M4
M22	23-31	≤4	50	≤5	70	
M23	[0.79]	[0.07]	[1.57]	[0.08]	[2.48]	M5
	20		40		63	
M24	[0.91]	1,7	[2.36]	2.1	[2.95]	
	23		60		75	

Note: Follow the instruction manual for motor fitting and installing. Improper handling can cause damages and malfunction.

General Specifications	Symbol	Units	PGM40
Axis distance		mm [in]	101 [3.98]
Output hollow dia.		mm [in]	50 [1.97]
Gear ratio	i		30
Max start / stop torque	T _U	N-m [in-lb]	63,9 [566]
Allowable mean output speed	N _m	rpm	100
Allowable ultimate output speed	N _U	rpm	150
Inertia moment on input axis	J	[lb-ft ²] x 10 ⁻⁴ kg.m ² x 10 ⁻⁴	[10.63] 0,448
Backlash		sec	60
Allowable axial Load on output	P _a	N [lbs]	1415 [318]
Allowable radial Load on output	P _r	N [lbs]	2172 [488]
Allowable moment Load on output	P _{mean}	N-m [in-lb]	102 [903]
Lubrication (Maintenance Free)			Grease
Weight		kg [lbs]	6,7 [14.77]

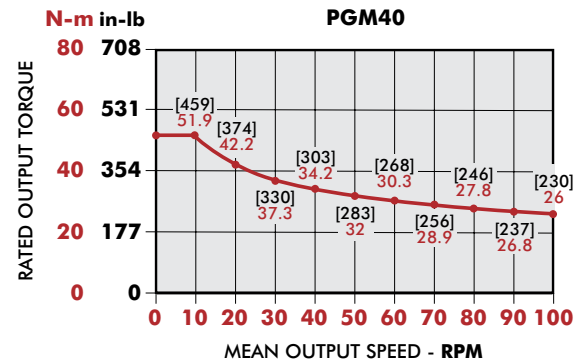

Sizing PGM Series for an Application

(Contact Destaco for sizing application support)

1. Load diagram

Check motion profile and resultant inertia torque.
(Add working torque if applied).

Start and stop speed can be simplified to average speed within a segment.

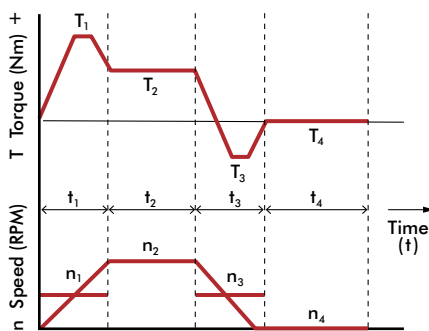

2. Check key conditions

$$\text{Mean torque } T_{mean} = \sqrt{\frac{\frac{10}{3} \left(n_1 \cdot t_1 \cdot |T_1| \frac{10}{3} + n_2 \cdot t_2 \cdot |T_2| \frac{10}{3} + \dots + n_n \cdot t_n \cdot |T_n| \frac{10}{3} \right)}{n_1 \cdot t_1 + n_2 \cdot t_2 + \dots + n_n \cdot t_n}} \quad (\text{N-m})$$

$$\text{Mean output speed } n_{mean} = \frac{n_1 \cdot t_1 + n_2 \cdot t_2 + \dots + n_n \cdot t_n}{t_1 + t_2 + \dots + t_n} \quad (\text{rpm})$$

$$\text{Max output speed } n_{max} \quad (\text{rpm})$$

3. Pre-selection

Choose a size that meets these criteria.

$$T_{mean} < \text{Maximum rated output torque (N-m)}$$

$$n_{mean} < \text{Allowable mean output speed } N_m \text{ (rpm)}$$

$$n_{max} < \text{Allowable ultimate output speed } N_u \text{ (rpm)}$$

4. Check specifications

Start/stop torque T₁ < Maximum rated output torque (N-m)
T₃ < Maximum rated output torque (N-m)

Operation condition factor Smooth without any impact or sudden load f = 1.0

Normal, but occasional emergency stop f = 1.5

Operation with frequent impact or sudden load f = 3.0

$$\text{Estimated lifetime } L_h = 12000 \left(\frac{T_{op}}{f \cdot T_{mean}} \right)^{\frac{10}{3}} \text{ (hours)}$$

5. Selection complete

If above values don't satisfy requirements, go back to step 2 and 3 to re-select size.

PGM40

Parallel Gear Servo Positioner | Dimensions

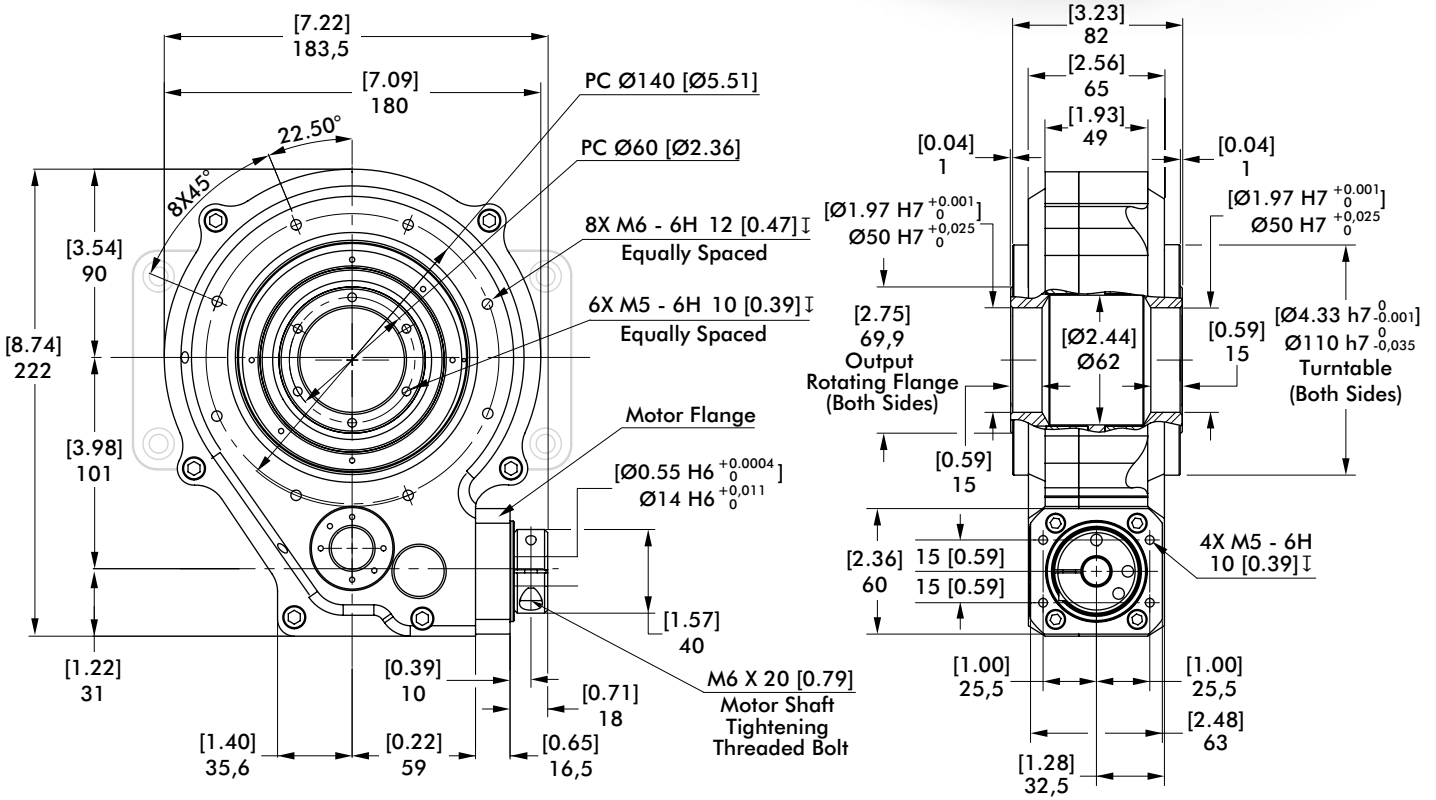
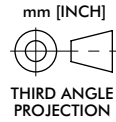

Optional Fixture Bracket

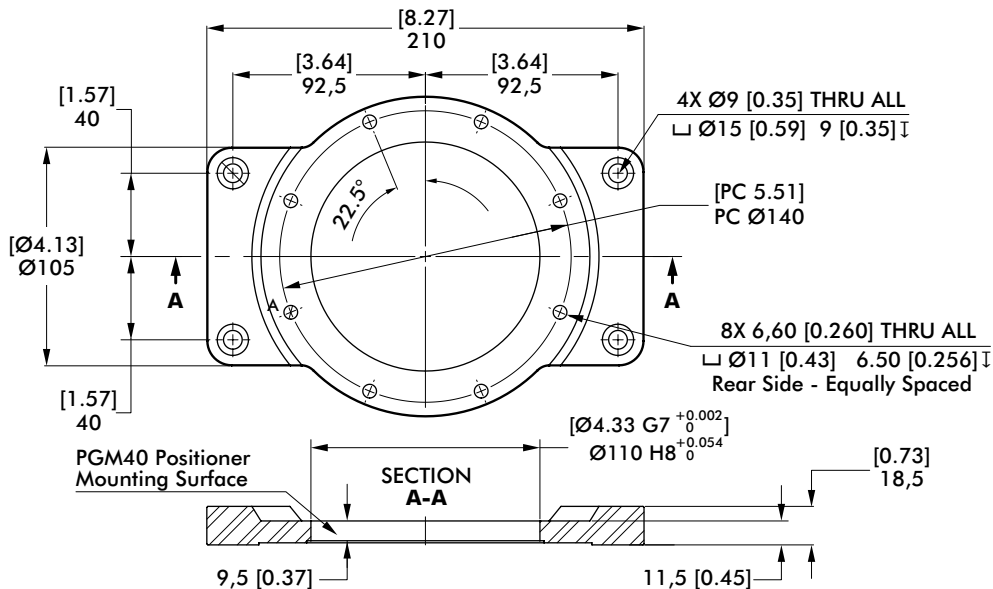

Parallel Gear Servo Positioner | Motor Base (by MI Code) Dimensions

