

85D5-2

Pneumatic Pin Package | Dual Shaft | Ordering Information

85D5-2 **C4** **L8** **10** **H0** **4** | **Stroke** 4 | **Description** 40 mm Stroke

Piston Rod	Description
C4	NAAMS Standard
D4	NAAMS Standard Rotated 180°

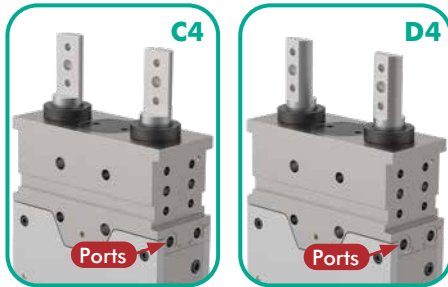

Hand Lever	Description
00	No Hand Lever
H0	Standard Hand Lever
HS	Weldable Hand Lever

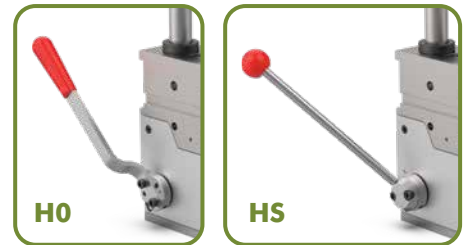

Hand Lever Shafts*	Description
10	Non-port side
20	Port side

*Hand Lever can be attached on either side of unit.

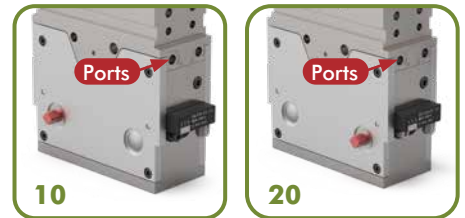

Sensor can be mounted on either side of unit by customer. Port side mounting shown.

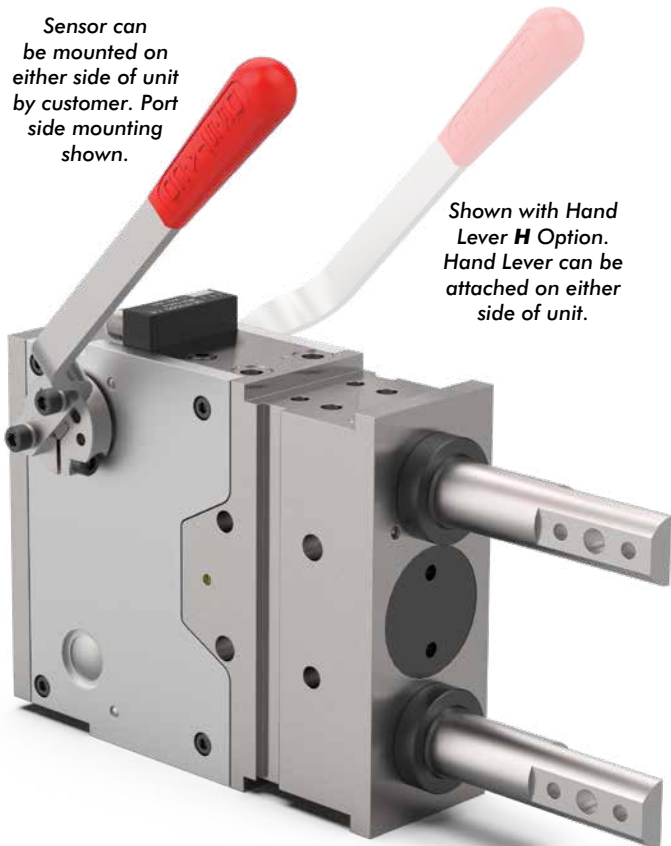

Shown with Hand Lever **H** Option. Hand Lever can be attached on either side of unit.

Sensor	Description
00	Without Sensing System
L8	PNP Sensor with In-line M12x1 Connector (8EA-146-4)
N8	NPN Sensor with In-line M12x1 Connector (8EA-154-4)
L9	PNP Sensor with 90° M12x1 Connector (8EA-147-4)
N9	NPN Sensor with 90° M12x1 Connector (8EA-155-4)
K8	PNP Sensor with M12x1 Cable Connector (8EA-158-4)
K9	NPN Sensor with M12x1 Cable Connector (8EA-167-4)

*Sensors can be mounted on opposite side by customer.

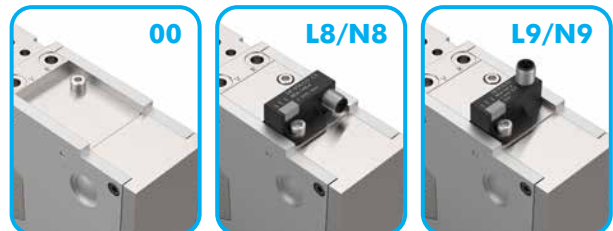

Pneumatic Pin Package | Dual Shaft | Dimensions and Technical Specifications

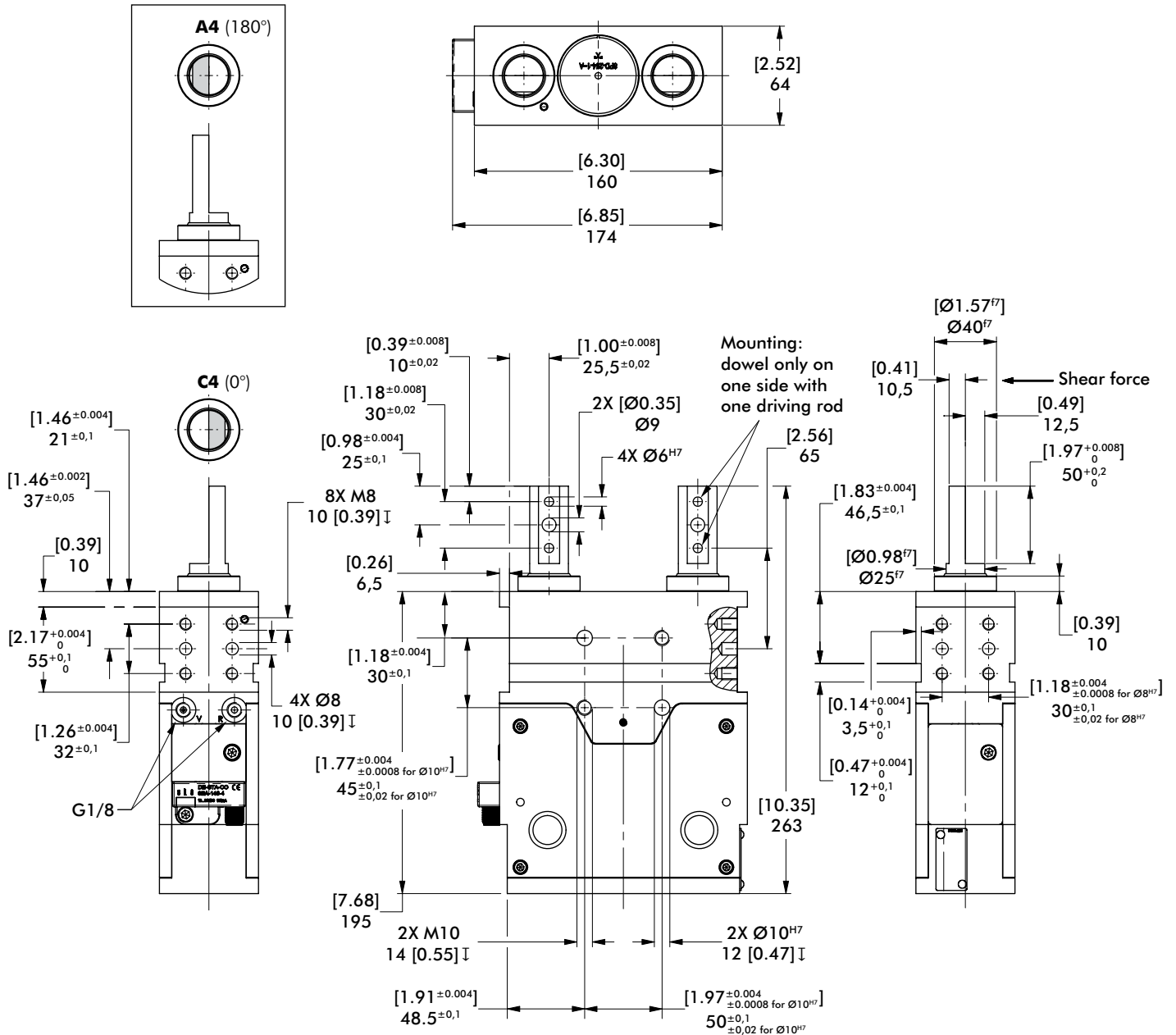

Medium: Operation with oil free air is permissible

Note: Extracting force and retracting force shown in this chart are only available with the last 2 mm stroke at extracted position. In the other range of the stroke the forces will be approximately 30% of value in the chart.

Base Model	Stroke mm [in]	Pushing Force at 6 bar N [lbf]	Retraction Force at 6 bar N [lbf]	Holding Force at 6 bar N [lbf]	Max. Operating Pressure bar [psi]	Piston Ø mm [in]	Weight Kg [lbs]	Air consumption per double stroke at 5 bar dm ³ [ft ³]
85D5-2	40 [1.57]	3500 [787]	2300 [517]	5000 [1124]	6 [87]	50 [1.97]	7,8 [17.20]	1,1 [0.04]

85D5-2 OPTIONS

Pneumatic Pin Package | Dual Shaft | Dimensions and Technical Specifications

H0 Standard Hand Lever

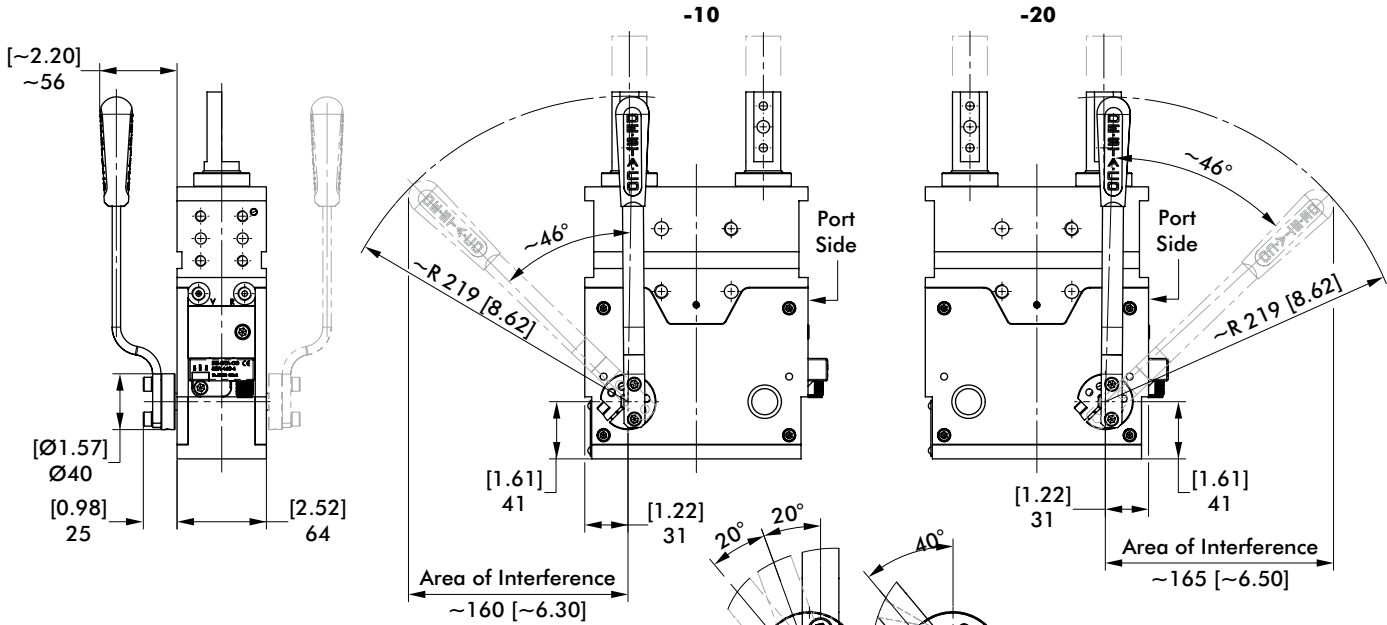

Note:
Specified dimensions for the area of interference apply only to the shown example.

The start position and the angle of the hand lever changes by mounting of the hand lever on the other side of the clamp or by rebuilding of the lever on the clamp piece.

Hand lever angle can be changed by further mounting options on the clamp piece

Model no.	Weight kg [lb]
85D5-2*****H04	8,3 [18.29]

H0 Weldable Hand Lever

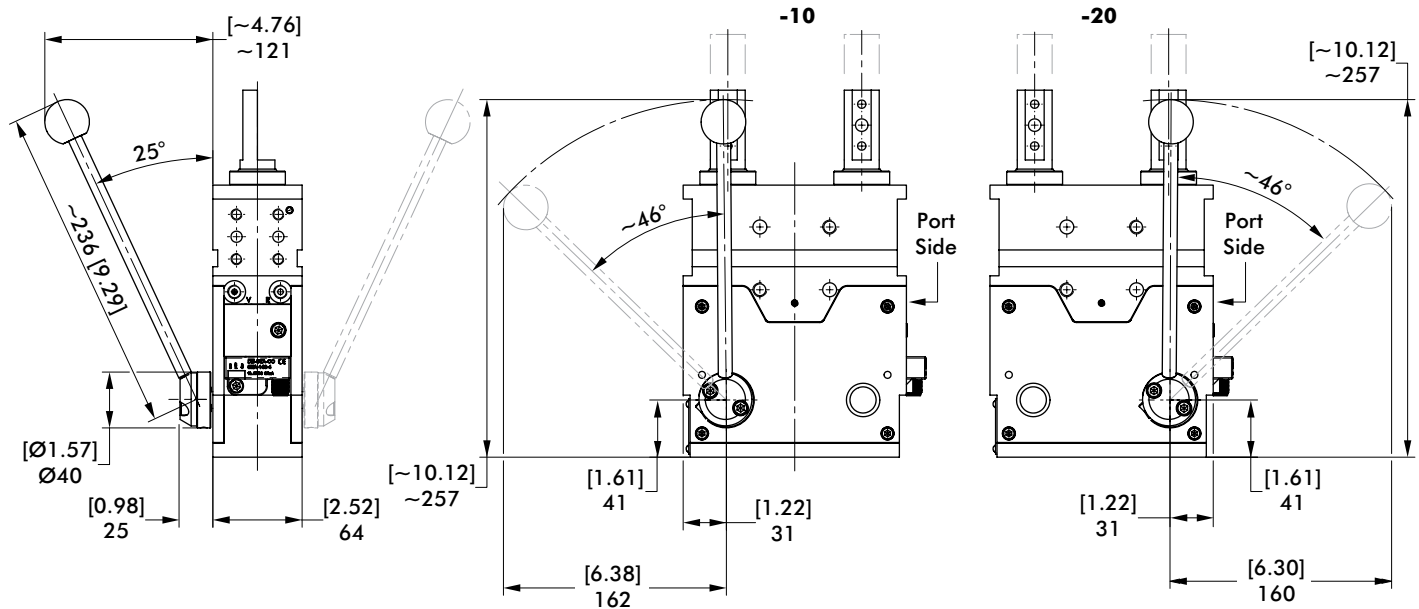

Note:
The view shows an example for a position of the welded hand lever.

The hand lever is delivered loose enclosed and can be welded by the customer in the required position. Easy custom left hand or right hand mounting in required position.

Model no.	Weight kg [lb]
85D5-2*****HS4	8,3 [18.29]

85D5-2 SENSORS

Pneumatic Pin Package | Dual Shaft | Dimensions and Technical Specifications

L8, N8 Inductive Sensing System

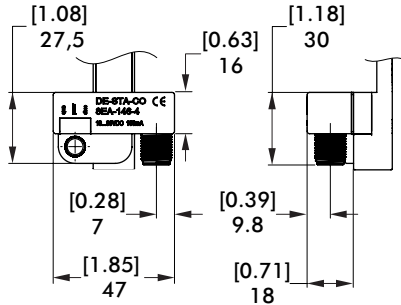

L9, N9 Inductive Sensing System with 90° Connector

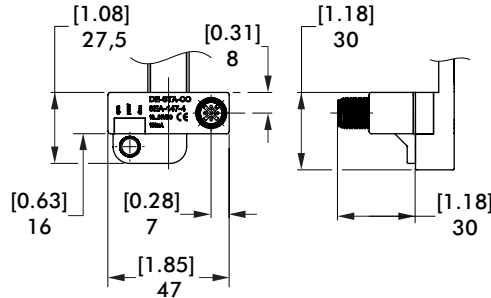

K8, K9 Inductive Sensing System with Pigtail Connector

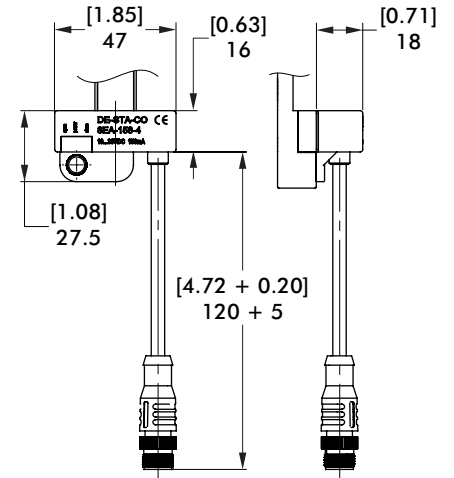

Inductive Sensor Wiring Diagram

Sensing system immune to interference from AC / DC arc welding.

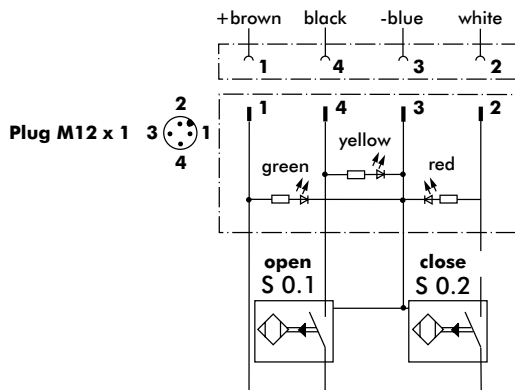

Sensor Cable Accessories

Sensor Cables (1 connector & 5m cable)	Order no.
M12x1 connector, straight, 5-pin	8EL-002-1
M12x1 connector, 90° angular, 4-pin	8EL-003-1

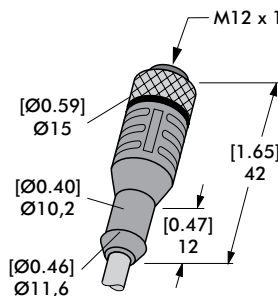

Straight Cable
8EL-002-1

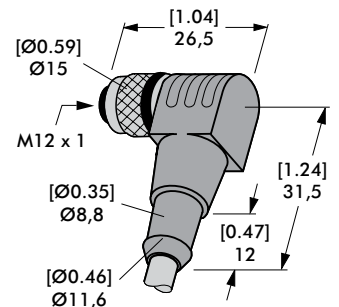

Angular Cable
8EL-003-1